

PRODUCT CATALOG

UNITED STATES EDITION

HIOSEN
IMPLANT



Hiossen Implant 2026 Product Catalog

Production/Distribution Marketing Headquarters

Date of Publication 05.2026

Version PC26HPCLTR1.1



Copyright © 2026 Hiossen Inc. All rights reserved.

105 Challenger Rd. 7th Floor, Ridgefield Park, NJ 07660

Marketing@hiossen.com | 888.678.0001 | www.hiossen.com

All Hiossen Implants are processed and Manufactured in the USA

PRODUCT CATALOG

INTRO	004
EK IMPLANT SYSTEM	011
ET IMPLANT SYSTEM	045
SS IMPLANT SYSTEM	087
EM IMPLANT SYSTEM	111
DIGITAL PROSTHETICS	117
HIOSSEN SURGICAL KIT	125
ORTHODONTIC SYSTEM	233
GBR & DENTAL MATERIAL	245
HIOSSEN EQUIPMENT	281

Hiossen Implant Surface feature

Surface treatment technologies are one of the key factors to ensure safe and efficient treatment, allowing improvement of the osseointegration between the implant and bone tissue.

HIOSSEN IMPLANT proudly presents its world-class surface technologies.

SA

Optimized surface morphology through acid-etching treatment

- Sand Blasted with Alumina and Acid-Etched
- Surface roughness: Ra 2.0-3.0 μm
(Note: the roughness in the upper 0.5mm part is Ra 0.5-0.6 μm)
- Uniform surface micro-pits of 1~3 μm
- Surface area increased by 46% compared to resorbable blast media (RBM) treated implants

In-vitro and In-vivo Bone Response

- Osteoblast differentiation and ossification improved by 20% compared to RBM-treated implants Initial bone response in a large animal model (mini-pig)
 - Initial stability (removal torque (RT), 4 weeks) improved by 48% compared to RBM-treated implants
 - Ossification (bone implant contact (BIC), 4 weeks) improved by 20% compared to RBM-treated implants

NH

Low crystalline nano-HA coated SA surface

- Faster Bone Healing. Improved Osseointegration
- 10nm or less ultra-thin hydroxyapatite (HA) coating
- SA surface (Ra 2.0-3.0 μm) coated with HA
- Dual functions of titanium and HA
 - HA is naturally resorbed during ossification

In-vitro and In-vivo Bone Response

- Combination of advantages of both SA surfaces and HA
 - SA's ability to maintain the optimal surface morphology
 - HA's ability of high-quality bone formation even in bones of poor quality
- Ossification (BIC) improved by 40% compared to SA surfaces
- Applicable to all types of bone quality compared to HA

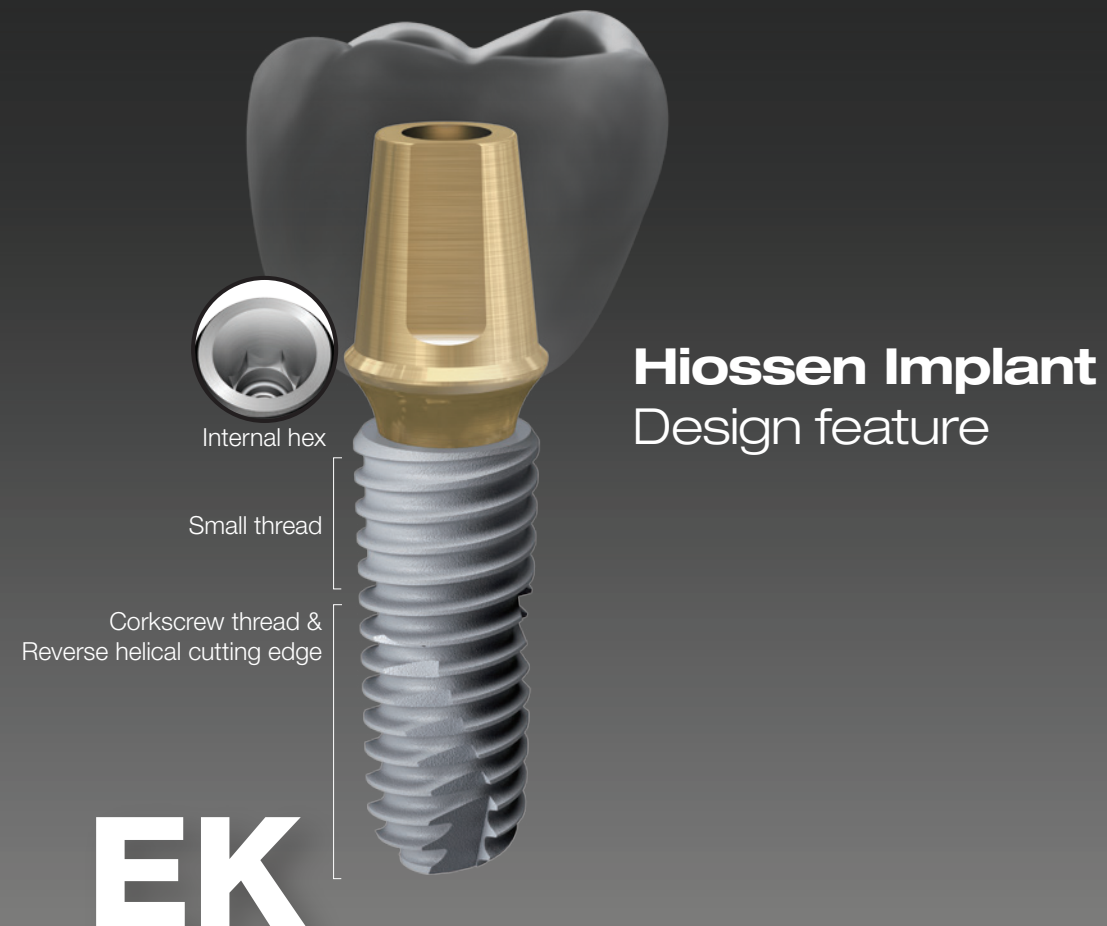

Next-generation submerged type implant with an internal hex 15° tapered connection structure

- Connection - **Regular only** (2.1 hex single platform)
 - Improved strength with a narrower and deeper connection
 - Reduced prosthetic errors and inventory burden because of not having to change the connection (**Mini / Regular**)
- Abutment holding system applied to enable screw fastening with one hand
- Effect of improved initial stability in soft bone by using smaller threads in the upper section
- Corkscrew thread & cutting edge
 - Superior self-threading effect for ease of placement path adjustment
 - Enhanced initial stability in soft bone and application of consistent placement torque according to the drill diameter
- Applicable surface types - SA / NH

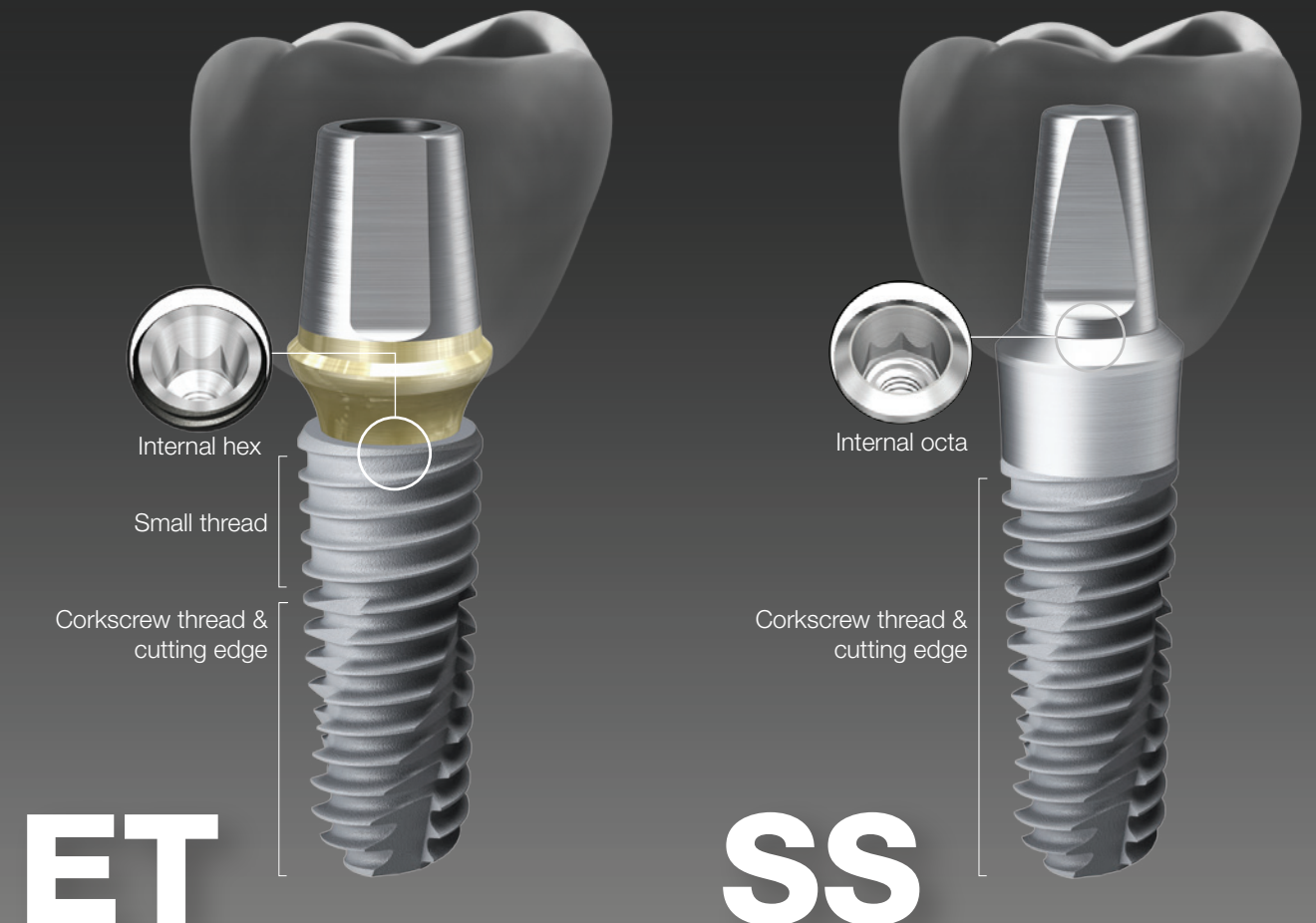

Submerged type implant with an internal hex 11° tapered connection structure

- Connection - **Mini / Regular**
- Effect of improved initial stability in soft bone with smaller threads in the upper section
- Corkscrew thread & cutting edge
 - Superior self-threading effect for ease of placement path adjustment
 - Enhanced initial stability in soft bone and application of consistent placement torque according to the drill diameter
- Various body shape options available to match the patient's bone quality and clinical condition
 - ETIII (1.5° tapered body) Excellent initial stability needed for immediate loading even in soft bone
 - ETIV (6° tapered body) Specifically designed for use in maxillary sinus and soft bone, providing excellent initial stability
- Applicable surface types - SA / NH

Non-submerged type implant with an internal octa 8° tapered connection based on the 1st stage surgery

- Connection - **Regular / Wide**
- Corkscrew thread & cutting edge
 - Superior self-threading effect for ease of placement path adjustment
 - Enhanced initial stability in soft bone and application of consistent placement torque according to the drill diameter
- Various body shape options available to match the patient's bone quality and clinical condition
 - SSII (straight body): Ease of placement depth adjustment
 - SSIII (1.5° tapered body): Excellent initial stability needed for immediate loading even in soft bone
- Applicable surface types - SA / NH

Hiossen Implant Marks 20 years of GLOBAL MARKET EXPANSION

Since our inception as the flagship US subsidiary of the Osstem group in 2006, Hiossen Implant has evolved from a Pennsylvania-based startup into a cornerstone of the global dental industry. Today, we stand at the threshold of a historic milestone: celebrating 30 years of Osstem's clinical innovation and 20 years of Hiossen's American-led excellence.

Ranked 3rd in global market share, our journey is defined by a relentless commitment to superior engineering and local clinical support. From our headquarters in Ridgefield Park, NJ, we command a worldwide network of 4,500 professionals across 70 countries—each dedicated to providing the innovative technology that practitioners trust and patients deserve.

WORLD WIDE & HISTORY

1997

Established Osstem, Korea

2006

Established Hiossen, Pennsylvania, USA

2007

Launched AIC Education Center
Advanced Dental Implant
Research and Education Center

2008

Establishment of Dental Implant
Manufacturing Facility, USA

2011

Launched ET III SA implant
(Sand-blasted & Acid-etched)

2013

Establishment of
SmartFit Center East
Comprehensive digital implant
scan, design, milling

2016

Launched ET III NH implant
(Nano-Hydrophilic)

2018

Recognized as TOP 5 in
Global Dental Implant Market
Launched K3 Unit Chair

2020

Establishment of
SmartFit Center West
Comprehensive digital implant
scan, design, milling

2022

Operating 17 sales regions
and 83 branches nationwide
Exporting to over 70 countries
Launched T2 CBCT

2023

The President "E" Award
Achievements in Exportation
by the U.S Department of Commerce

2024

Launched EK III implant
(Nano-Hydrophilic)
Launched K5 Unit Chair
Launched T2Plus CBCT
Launched Hiossen Digital Center
Recognized as TOP 3 in
Global Dental Implant Market

2025

Launched Dental Night Guard
Launched Scan Healing Abutment

2026

20 years of Global Market Expansion

GLOBAL FOOTPRINT TODAY

We are rapidly expanding globally, operating in 40 countries and exporting to over 70 countries.

40
Countries
Operating

70
Countries
Sales Distribution



Albania	Georgia	Mexico	Slovenia
Australia	Germany	Mongolia	South Korea
Azerbaijan	Greece	Morocco	Spain
Bangladesh	Hungary	Netherlands	Sweden
Beijing (China)	India	New Zealand	Switzerland
Belarus	Indonesia	Norway	Taiwan
Bosnia	Italy	Pakistan	Thailand
Brazil	Japan	Peru	Tianjin (China)
Bulgaria	Jordan	Philippines	Turkiye
Canada	Kazakhstan	Poland	United Arab
Chile	Kosovo	Portugal	Emirates
Croatia	Kuwait	Romania	Ukraine
Cyprus	Latvia	Russia	United Kingdom
Czech Republic	Lebanon	Saudi Arabia	United States
Egypt	Libya	Serbia	Uzbekistan
Estonia	Lithuania	Shenzhen (China)	Vietnam
Finland	Malaysia	Singapore	
France	Macedonia	Slovakia	

HIOSSEN
IMPLANT



IMPLANT SYSTEM

IMPLANT

EK Implant System Intro	012
EK Implant System	014
Mount & Screws	015
Healing Abutment	016

COMPONENTS

PROSTHETIC FLOW DIAGRAM 1	018
Rigid Abutment	019
PROSTHETIC FLOW DIAGRAM 2	022
Transfer Abutment	021
Angled Abutment	022
Freeform ST Abutment	023
Goldcast / NP-Cast Abutment	024
Temporary Abutment	025
PROSTHETIC FLOW DIAGRAM 3	032
Multi Abutment	033
Multi Angled Abutment	034
PROSTHETIC FLOW DIAGRAM 4	036
Stud Abutment	037
Locator® Legacy Abutment	038
Locator® R-TX Abutment	042

EK Design & Surface Feature

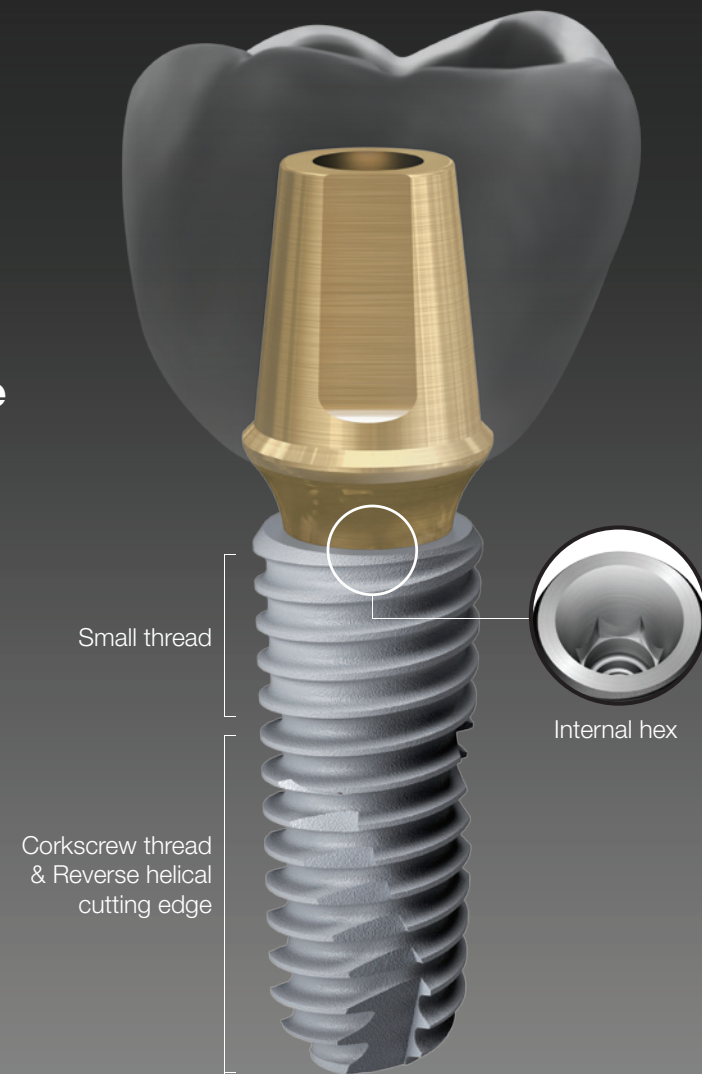

EK

Next-generation submerged type implant with an internal hex 15° tapered connection structure

- Connection - **Regular only** (2.1 hex single platform)
 - Improved strength with a narrower and deeper connection
 - Reduced prosthetic errors and inventory burden because of not having to change the connection (**Mini / Regular**)
- Abutment holding system applied to enable screw fastening with one hand
- Effect of improved initial stability in soft bone by using smaller threads in the upper section
- Corkscrew thread & cutting edge
 - Superior self-threading effect for ease of placement path adjustment
 - Enhanced initial stability in soft bone and application of consistent placement torque according to the drill diameter
- Applicable surface types - SA / NH

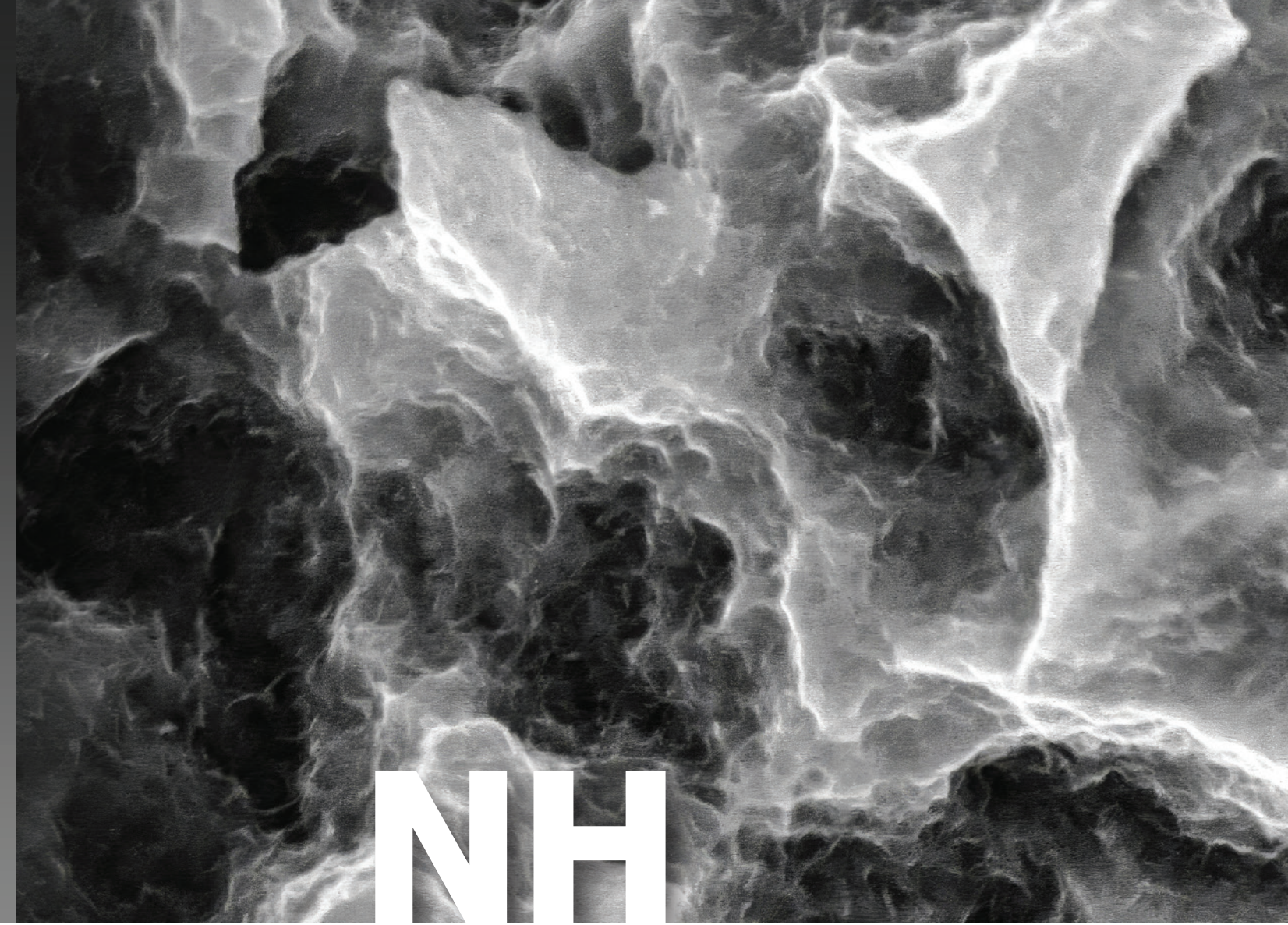

Low crystalline nano-HA coated SA surface

- Faster Bone Healing. Improved Osseointegration
- 10nm or less ultra-thin hydroxyapatite (HA) coating
- SA surface (Ra 2.0-3.0um) coated with HA
- Dual functions of titanium and HA
 - HA is naturally resorbed during ossification

In-vitro and In-vivo Bone Response

- Combination of advantages of both SA surfaces and HA
 - SA's ability to maintain the optimal surface morphology
 - HA's ability of high-quality bone formation even in bones of poor quality
- Ossification (BIC) improved by 40% compared to SA surfaces
- Applicable to all types of bone quality compared to HA



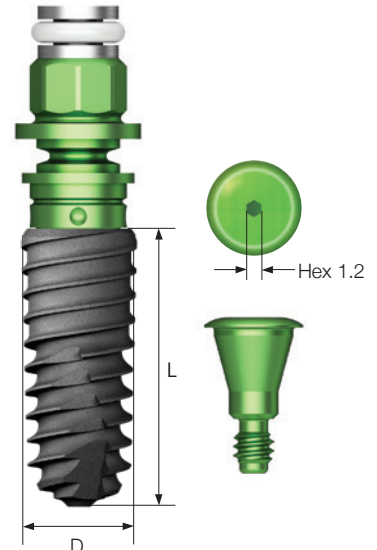

EK Implant System

EK Implant System	Guide
<p>Description</p> <ul style="list-style-type: none"> • Next-generation submerged type implant with 15° Morse Taper Connection • Connection: Single Platform (2.1 Hex) <ul style="list-style-type: none"> - Increased implant wall thickness with deeper implant connection - Improved inventory management efficiency • 1.5° Tapered body with buttress threads increases the contact surface with the bone • Smaller threads in the upper section improve primary stability <p>Narrow</p> <ul style="list-style-type: none"> • Used for narrow bone width • For anterior region extraction <p>Ultra-Wide</p> <ul style="list-style-type: none"> • Indicated for posterior region extraction, immediate implant replacement, and failed implant replacement • Apex design allows implant to achieve initial stability from extractions with 3mm or less • Recommended placement torque: 40Ncm or less • Recommended implant size in posterior: Ø4.5 or above <div style="border: 1px solid black; border-radius: 15px; padding: 10px; margin-top: 20px;"> <p>Order Code</p> <p>NoMount Implant: Code starts with "C"</p> <p>Mount Implant: Code starts with "A"</p> </div>	

Platform	Single							
Hex	Hex 2.1							
F	F3.3	F3.5	F4.0	F4.5	F5.0	F5.5	F6.0	F7.0
 L								
6mm	-	-	-	-	-	-	EK3S6006B	EK3S7006B
7mm	-	-	EK3S4007B	EK3S4507B	EK3S5007B	EK3S5507B	EK3S6007B	EK3S7007B
8.5mm	EK3S3008B	EK3S3508B	EK3S4008B	EK3S4508B	EK3S5008B	EK3S5508B	EK3S6008B	EK3S7008B
10mm	EK3S3010B	EK3S3510B	EK3S4010B	EK3S4510B	EK3S5010B	EK3S5510B	EK3S6010B	EK3S7010B
11.5mm	EK3S3011B	EK3S3511B	EK3S4011B	EK3S4511B	EK3S5011B	EK3S5511B	EK3S6011B	EK3S7011B
13 mm	EK3S3013B	EK3S3513B	EK3S4013B	EK3S4513B	EK3S5013B	EK3S5513B	EK3S6013B	EK3S7013B

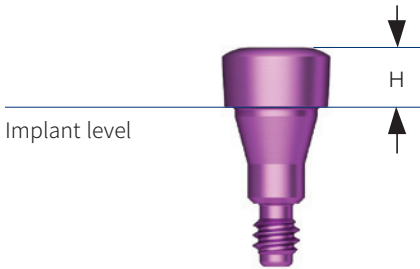
※ Specifications are subject to change without any notice

Mount & Screw

Cover Screw	
Description	Guide
<ul style="list-style-type: none"> Cover screw height (H) depends on the depth of implant placement Ø3.3 an Ø3.5 implants use exclusive cover screws Tighten with 1.2 Hex Hand Driver 	 <p>The diagram shows a purple cover screw. A horizontal line labeled 'Implant level' is drawn across the middle of the screw's conical part. A vertical double-headed arrow labeled 'H' indicates the height from the top of the screw to the implant level.</p>
H	0.4
For Ø3.0	 <p>EKCS30S</p>
For Ø3.5	 <p>EKCS35S</p>
For Ø4.0 and above	 <p>EKCS40S</p>

Healing Abutment

Healing Abutment						
Description	Image/Guide					
<ul style="list-style-type: none"> Hand tighten it with a 1.2 hex driver The gingiva height is 0.5mm higher when engaged in Ø3.5 implant 						
Reference table						
Healing abutment	H	3.0	4.0	5.0	6.0 & Above	
Abutment	G/H	1.0	2.0 or 3.0	3.0 or 4.0	5.0 & Above	
Impression coping	Type	Short	Short	Long	Long	

H	3.0	4.0	5.0	6.0	7.0	9.0
D						
Ø4.0	EKHA403	EKHA404	EKHA405	EKHA406	EKHA406	EKHA409
Ø4.5	EKHA453	EKHA454	EKHA455	EKHA456	EKHA456	EKHA459
Ø5.0	EKHA503	EKHA504	EKHA505	EKHA506	EKHA506	EKHA509
Ø6.0	EKHA603	EKHA604	EKHA605	EKHA606	EKHA606	EKHA609
Ø7.0	EKHA703	EKHA704	EKHA705	EKHA706	EKHA706	EKHA709
Ø8.0	-	-	EKHA805	-	-	-

HIOSSSEN
IMPLANT

PROSTHETIC FLOW DIAGRAM 1





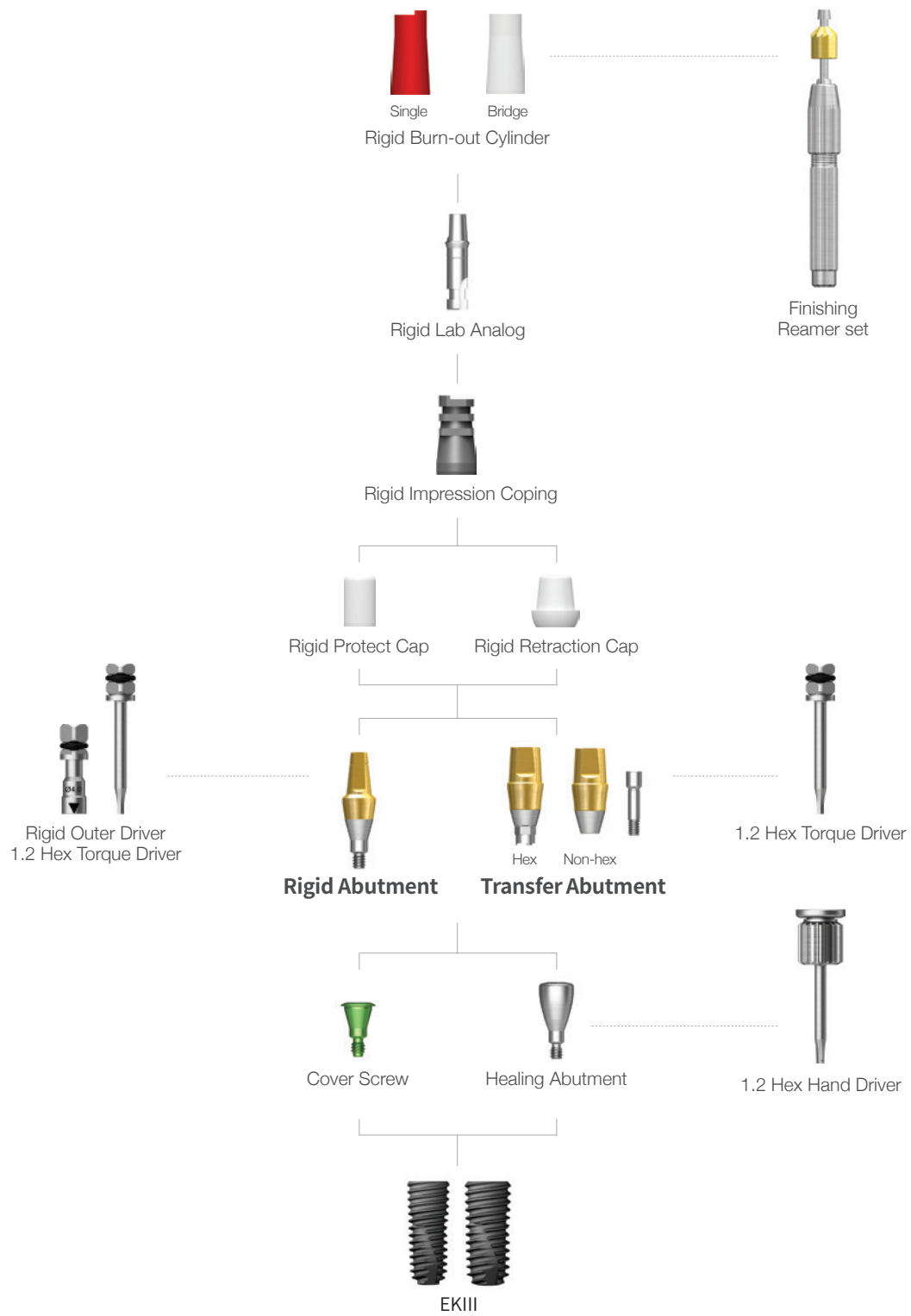

Rigid

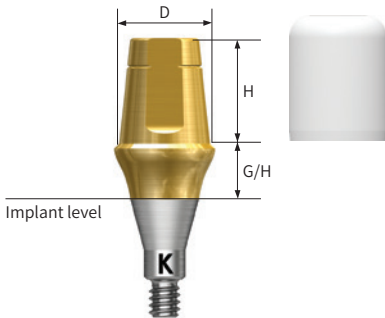





Abutment Level Impression









Rigid Abutment







Rigid Abutment	
Description	Image/Guide
<ul style="list-style-type: none"> Cement-retained prosthesis Abutment level impression Ø4.0: torque using the outer driver (code: HORDML/HORDMS) Ø4.5/5.0/6.0: torque using the outer driver or 1.2 hex driver Ø7.0: torque using a 1.2 hex driver The gingiva height is 0.5mm higher when engaged in Ø3.5 implant Recommended tightening torque: 30Ncm Packing unit: Abutment + Protect cap <p>※ Compatible with ET Rigid Abutment Component, please refer to page 56-57</p>  <p>EK products are marked with "K".</p>	

Ø4.0						
G/H	1.0	2.0	3.0	4.0	5.0	
						
H						
4.0	EKRA4410P	EKRA4420P	EKRA4430P	EKRA4440P	EKRA4450P	
5.5	EKRA4610P	EKRA4620P	EKRA4630P	EKRA4640P	EKRA4650P	
7.0	EKRA4710P	EKRA4720P	EKRA4730P	EKRA4740P	EKRA4750P	

Ø4.5						
G/H	1.0	2.0	3.0	4.0	5.0	
						
H						
4.0	EKRA4411P	EKRA4421P	EKRA4431P	EKRA4441P	EKRA4451P	
5.5	EKRA4611P	EKRA4621P	EKRA4631P	EKRA4641P	EKRA4651P	
7.0	EKRA4711P	EKRA4721P	EKRA4731P	EKRA4741P	EKRA4751P	

Rigid Abutment

Ø5.0					
G/H	1.0	2.0	3.0	4.0	5.0
 H					
4.0	EKRA5410P	EKRA5420P	EKRA5430P	EKRA5440P	EKRA5450P
5.5	EKRA5610P	EKRA5620P	EKRA5630P	EKRA5640P	EKRA5650P
7.0	EKRA5710P	EKRA5720P	EKRA5730P	EKRA5740P	EKRA5750P

Ø6.0					
G/H	1.0	2.0	3.0	4.0	5.0
 H					
4.0	EKRA6410P	EKRA6420P	EKRA6430P	EKRA6440P	EKRA6450P
5.5	EKRA6610P	EKRA6620P	EKRA6630P	EKRA6640P	EKRA6650P
7.0	EKRA6710P	EKRA6720P	EKRA6730P	EKRA6740P	EKRA6750P

Ø7.0					
G/H	1.0	2.0	3.0	4.0	5.0
 H					
5.5	EKRA7610P	EKRA7620P	EKRA7630P	EKRA7640P	EKRA7650P

※ Specifications are subject to change without any notice



HIOSSEN
IMPLANT



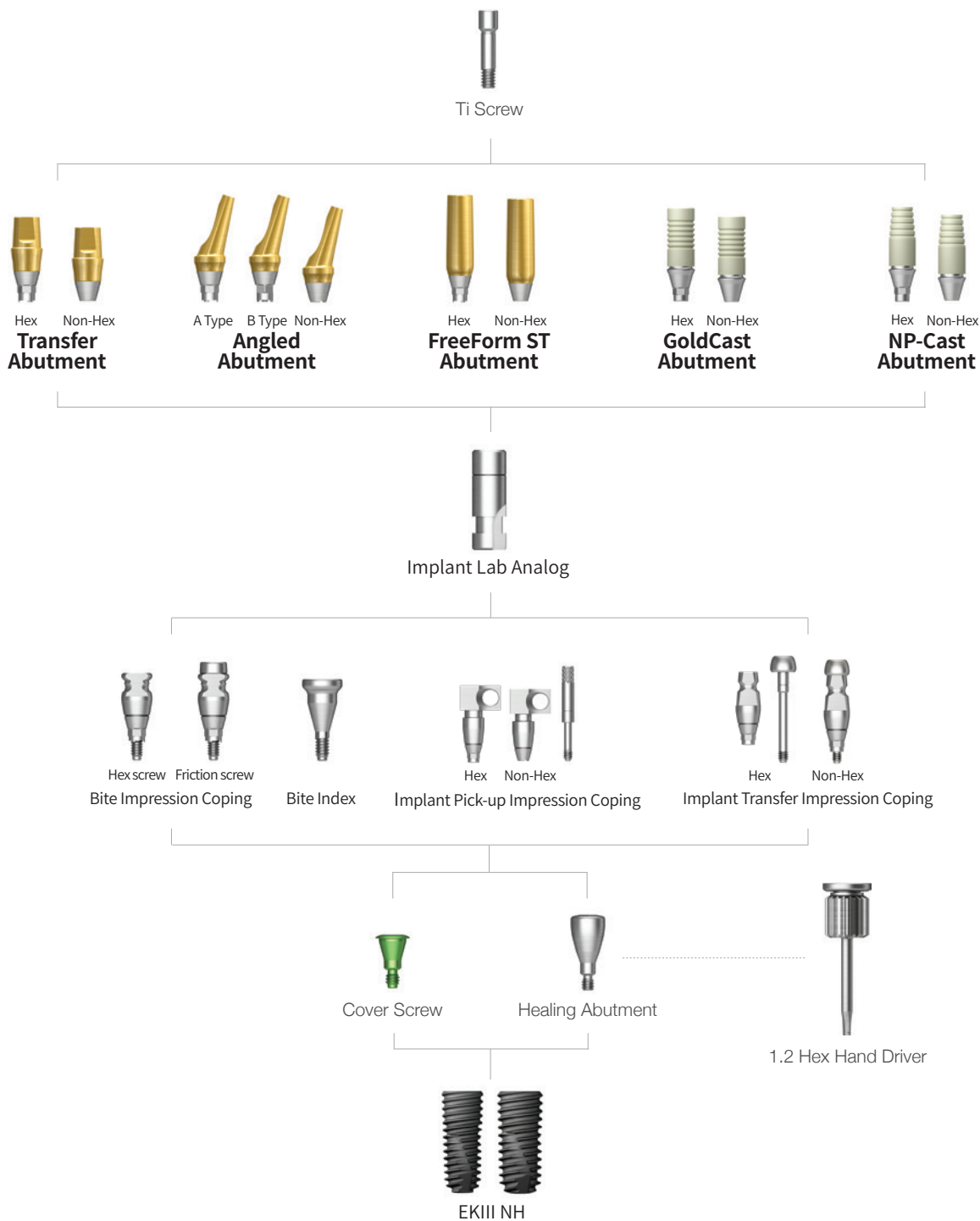

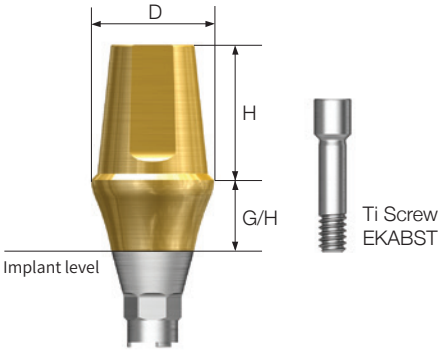

Transfer / Angled / FreeForm ST / GoldCast / NP-Cast

Implant Level Impression









Transfer Abutment

Transfer Abutment	Image/Guide
<p>Description</p> <ul style="list-style-type: none"> • Cement-retained/combination prosthesis • Implant level impression • Abutment level impression is available using the rigid impression coping (Ø4.0 excluded) • Abutment Holding System allows abutment engagement in the maxilla with a single hand • The gingiva height is 0.5mm higher when engaged in Ø3.5 implant • Torque using 1.2 Hex Driver • Recommended tightening torque: 30Ncm • Packing unit: Abutment + Ti Screw <div style="display: flex; justify-content: space-around; align-items: center;"> <div style="text-align: center;">  <p>EK Hex Abutments have Abutment Holding System at the bottom</p> </div> <div style="text-align: center;">  <p>EK Non-Hex abutments have three indents at the bottom</p> </div> </div>	

Ø4.0						
G/H	1.0	2.0	3.0	4.0	5.0	
 H						
Hex	5.5	EKTA4612TH	EKTA4622TH	EKTA4632TH	EKTA4642TH	EKTA4652TH
	7.0	EKTA4712TH	EKTA4722TH	EKTA4732TH	EKTA4742TH	EKTA4752TH
Non-Hex	5.5	EKTA4612NTH	EKTA4622NTH	EKTA4632NTH	EKTA4642NTH	EKTA4652NTH
	7.0	EKTA4712NTH	EKTA4722NTH	EKTA4732NTH	EKTA4742NTH	EKTA4752NTH
Ø4.5						
Hex	5.5	EKTA4611TH	EKTA4621TH	EKTA4631TH	EKTA4641TH	EKTA4651TH
	7.0	EKTA4711TH	EKTA4721TH	EKTA4731TH	EKTA4741TH	EKTA4751TH
Non-Hex	5.5	EKTA4611NTH	EKTA4621NTH	EKTA4631NTH	EKTA4641NTH	EKTA4651NTH
	7.0	EKTA4711NTH	EKTA4721NTH	EKTA4731NTH	EKTA4741NTH	EKTA4751NTH

Transfer Abutment

Ø5.0						
G/H	1.0	2.0	3.0	4.0	5.0	
						
H						
Hex	4.0	EKTA5410TH	EKTA5420TH	EKTA5430TH	EKTA5440TH	EKTA5450TH
	5.5	EKTA5610TH	EKTA5620TH	EKTA5630TH	EKTA5640TH	EKTA5650TH
	7.0	EKTA5710TH	EKTA5720TH	EKTA5730TH	EKTA5740TH	EKTA5750TH
Non-Hex	4.0	EKTA5410NTH	EKTA5420NTH	EKTA5430NTH	EKTA5440NTH	EKTA5450NTH
	5.5	EKTA5610NTH	EKTA5620NTH	EKTA5630NTH	EKTA5640NTH	EKTA5650NTH
	7.0	EKTA5710NTH	EKTA5720NTH	EKTA5730NTH	EKTA5740NTH	EKTA5750NTH
Ø6.0						
Hex	4.0	EKTA6410TH	EKTA6420TH	EKTA6430TH	EKTA6440TH	EKTA6450TH
	5.5	EKTA6610TH	EKTA6620TH	EKTA6630TH	EKTA6640TH	EKTA6650TH
	7.0	EKTA6710TH	EKTA6720TH	EKTA6730TH	EKTA6740TH	EKTA6750TH
Non-Hex	4.0	EKTA6410NTH	EKTA6420NTH	EKTA6430NTH	EKTA6440NTH	EKTA6450NTH
	5.5	EKTA6610NTH	EKTA6620NTH	EKTA6630NTH	EKTA6640NTH	EKTA6650NTH
	7.0	EKTA6710NTH	EKTA6720NTH	EKTA6730NTH	EKTA6740NTH	EKTA6750NTH
Ø7.0						
Hex	4.0	EKTA7410TH	EKTA7420TH	EKTA7430TH	EKTA7440TH	EKTA7450TH
	5.5	EKTA7610TH	EKTA7620TH	EKTA7630TH	EKTA7640TH	EKTA7650TH
Non-Hex	4.0	EKTA7410NTH	EKTA7420NTH	EKTA7430NTH	EKTA7440NTH	EKTA7450NTH
	5.5	EKTA7610NTH	EKTA7620NTH	EKTA7630NTH	EKTA7640NTH	EKTA7650NTH

Transfer Abutment Components











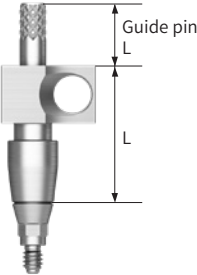

Bite Impression Coping			Image/Guide					
Description			Image/Guide					
<ul style="list-style-type: none"> Designed for implant level impression 2-in-1 tool for bite registration and taking impression Utilizes same impression technique when using transfer impression coping Hand tighten with Bite Impression Coping Driver (HICDMH) 			<p>EK Non-Hex abutments have three indents at the bottom</p> <p>Hex screw type</p>					
G/H			2.0	3.0	4.0	5.0	6.0	
H								
Ø4.0	Hex	4.0	EKBIC4420H	EKBIC4430H	EKBIC4440H	EKBIC4450H	EKBIC4460H	
		5.0	EKBIC4520H	EKBIC4530H	EKBIC4540H	EKBIC4550H	EKBIC4560H	
		6.0	EKBIC4620H	EKBIC4630H	EKBIC4640H	EKBIC4650H	EKBIC4660H	
Ø4.5	Hex	4.0	EKBIC4421H	EKBIC4431H	EKBIC4441H	EKBIC4451H	EKBIC4461H	
		5.0	EKBIC4521H	EKBIC4531H	EKBIC4541H	EKBIC4551H	EKBIC4561H	
		6.0	EKBIC4621H	EKBIC4631H	EKBIC4641H	EKBIC4651H	EKBIC4661H	
Ø5.0	Hex	4.0	EKBIC5420H	EKBIC5430H	EKBIC5440H	EKBIC5450H	EKBIC5460H	
		5.0	EKBIC5520H	EKBIC5530H	EKBIC5540H	EKBIC5550H	EKBIC5560H	
		6.0	EKBIC5620H	EKBIC5630H	EKBIC5640H	EKBIC5650H	EKBIC5660H	

※ EK Bite Impression Coping does not feature Abutment Holding System

Bite Impression Coping Driver		
Description	Type	Image
<ul style="list-style-type: none"> Tailored for tightening and loosening the bite impression coping A driver for hex screw type 	Hex	<p>HICDMH</p>





Bite Index						
Description	L	4.0	6.0	8.0	10.0	12.0
<ul style="list-style-type: none"> The gingival height is 0.5mm higher when engaged in Ø3.5 implant Engage to implant for checking bite impression Tighten with 1.2 Hex Hand Driver Packing unit: 2ea 						
	Ø4.5	EKBI4504S	EKBI4506S	EKBI4508S	EKBI4510S	EKBI4512S
	Ø5.5	EKBI5504S	EKBI5506S	EKBI5508S	EKBI5510S	EKBI5512S

Transfer Abutment Components

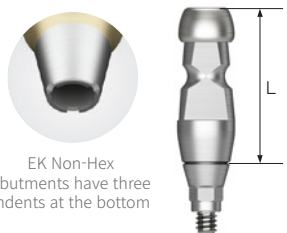

Implant Pick-up Impression Coping							
Description		Hex	Non-Hex	Guide Pin			
	L	11		0	5.0	10	15
<ul style="list-style-type: none"> • Components for implant level impression • Open Tray impression coping • Ensures precise positioning of internal hex in impression • The gingival height is 0.5mm higher when engaged in Ø3.5 implant • Tighten with 1.2 Hex Hand Driver • Packing unit: Impression coping body + guide pin* <p>* Standard guide pin length</p>   <p>EK Non-Hex abutments have three indents at the bottom</p>							
	Ø4.0	EKPI4011	EKPI4011N				
	Ø4.5	EKPI4511	EKPI4511N				
	Ø5.0	EKPI5011	EKPI5011N	EKPGP100	EKPGP150*	EKPGP200	EKPGP250
	Ø6.0	EKPI6011	EKPI6011N				
	Ø7.0	EKPI7011	EKPI7011N				
		Hex	Non-Hex	Guide Pin			
L		16			0	5.0	10
							
Ø4.0	EKPI4016	EKPI4016N					
Ø4.5	EKPI4516	EKPI4516N					
Ø5.0	EKPI5016	EKPI5016N		-	EKPGP150	EKPGP200*	EKPGP250
Ø6.0	EKPI6016	EKPI6016N					
Ø7.0	EKPI7016	EKPI7016N					



※ EK Pick-up Impression Coping does not feature the Abutment Holding System

Transfer Abutment Components



Implant Transfer Impression Coping					
Description		Hex	Non-Hex	Hex	Non-Hex
	L	11		14	
<ul style="list-style-type: none"> • Components for implant level impression • Closed Tray impression • Features a triangular arc structure for precise repositioning • The gingival height is 0.5mm higher when engaged in Ø3.5 implant • Tighten with 1.2 Hex Hand Driver • Packing unit: <ul style="list-style-type: none"> - Hex: Impression coping body + guide pin - Non-Hex: Impression coping body  <p>EK Non-Hex abutments have three indents at the bottom</p>					
	Ø4.0	EKTI4011	EKTI4011N	EKTI4014	EKTI4014N
	Ø4.5	EKTI4511	EKTI4511N	EKTI4514	EKTI4514N
	Ø5.0	EKTI5011	EKTI5011N	EKTI5014	EKTI5014N
	Ø6.0	EKTI6011	EKTI6011N	EKTI6014	EKTI6014N
	Ø7.0	EKTI7011	EKTI7011N	EKTI7014	EKTI7014N





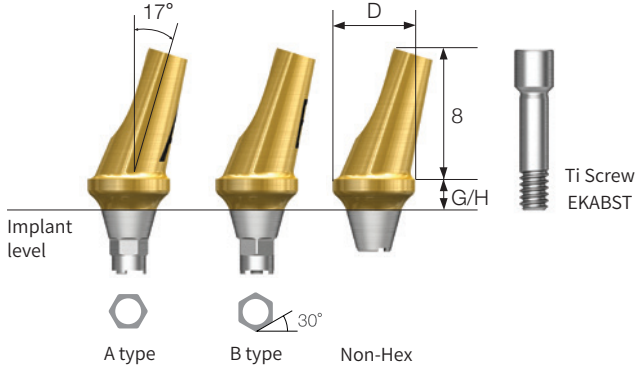

※ EK Transfer Impression Coping does not feature Abutment Holding System

Laboratory Screw		
Description	Lab Screw	Waxing Screw
<ul style="list-style-type: none"> • Laboratory screw: Designed specifically for laboratory tasks • Waxing screw: Utilized in creating screw-type abutments and transfer jigs by extending the screw hole to the abutment 		
	EKABSL	EKABSW

Transfer Lab Analog		
Description	Ø3.3 / Ø3.5	Ø4.0 and Above
<ul style="list-style-type: none"> • Laboratory analog for capturing implant level impressions • There are two variations, each tailored for implants with a diameter of Ø3.5/4.0 or larger 		
	EKTLA350	EKTLA400

Angled Abutment

Angled Abutment	
Description	Image/Guide
<ul style="list-style-type: none"> Cement-retained/combination prosthesis Abutment designed to compensate up to 23° without removal Suitable for implant level impression The gingival height is 0.5mm higher when engaged in Ø3.5 implant Torque using 1.2 Hex Driver Recommended tightening torque: 30Ncm Packing unit: Abutment + Ti Screw <div style="display: flex; justify-content: space-around; align-items: center;"> <div style="text-align: center;">  <p>EK Hex Abutments have Abutment Holding System at the bottom</p> </div> <div style="text-align: center;">  <p>EK Non-Hex abutments have three indents at the bottom</p> </div> </div>	

G/H	2.0			4.0		
	Hex A	Hex B	Non-Hex	Hex A	Hex B	Non-Hex
						
Ø4.0	EKAA4020ATH	EKAA4020BTH	EKAA4020NTH	EKAA4040ATH	EKAA4040BTH	EKAA4040NTH
Ø4.5	EKAA4520ATH	EKAA4520BTH	EKAA4520NTH	EKAA4540ATH	EKAA4540BTH	EKAA4540NTH
Ø5.5	EKAA5020ATH	EKAA5020BTH	EKAA5020NTH	EKAA5040ATH	EKAA5040BTH	EKAA5040NTH
Ø6.0	EKAA6020ATH	EKAA6020BTH	EKAA6020NTH	EKAA6040ATH	EKAA6040BTH	EKAA6040NTH

FreeForm ST Abutment

FreeForm ST Abutment				
Description		Image/Guide		
<ul style="list-style-type: none"> Cement-retained/combination prosthesis Utilized to modify contour of abutment margins Suitable for implant level impression The gingival height is 0.5mm higher when engaged in Ø3.5 implant Torque using 1.2 Hex Driver Recommended tightening torque: 30Ncm Packing unit: Abutment + Ti Screw 				
G/H	1.5		3.0	
Type	Hex	Non-Hex	Hex	Non-Hex
Ø4.0	EKFA4015TH	EKFA4015NTH	EKFA4030TH	EKFA4030NTH
Ø5.0 (straight)	EKFAS5015TH	EKFAS5015NTH	EKFAS5030TH	EKFAS5030NTH
G/H	1.5		3.0	
Type	Hex	Non-Hex	Hex	Non-Hex
Ø5.0	EKFA5015TH	EKFA5015NTH	EKFA5030TH	EKFA5030NTH
Ø6.0	EKFA6015TH	EKFA6015NTH	EKFA6030TH	EKFA6030NTH
Ø7.0	EKFA7015TH	EKFA7015NTH	EKFA7030TH	EKFA7030NTH









GoldCast Abutment

GoldCast Abutment				
Description			Image/Guide	
<ul style="list-style-type: none"> Cement-retained/combination prosthesis Abutment used to produce customized prosthesis through gold alloy casting Melting temperature of abutment: 1,400 ~1,450°C (2,552~2,822°F) Suitable for implant level impression The gingival height is 0.5mm higher when engaged in Ø3.5 implant Torque using 1.2 Hex Driver Recommended tightening torque: 30Ncm Packing Unit: Abutment + Ti Screw 			<p>EK Hex Abutments have Abutment Holding System at the bottom</p> <p>EK Non-Hex Abutments have three indents at the bottom</p>	
G/H	1.0		3.0	
Type	Hex	Non-Hex	Hex	Non-Hex
Ø4.0	EKGA4010TH	EKGA4010NTH	EKGA4030TH	EKGA4030NTH
Ø4.5	EKGA4510TH	EKGA4510NTH	EKGA4530TH	EKGA4530NTH

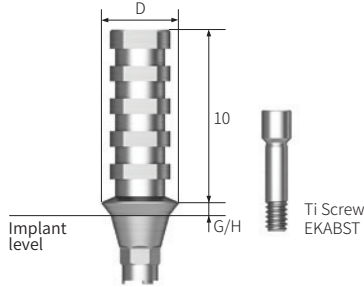
NP-Cast Abutment

NP-Cast Abutment				
Description			Image/Guide	
<ul style="list-style-type: none"> Cement-retained/combination prosthesis Abutment used to produce customized prosthesis through non-precious alloy Melting temperature of abutment: 1,400 ~1,450°C (2,552~2,822°F) Suitable for implant level impression The gingival height is 0.5mm higher when engaged in Ø3.5 implant Torque using 1.2 Hex Driver Recommended tightening torque: 30Ncm Packing Unit: Abutment + Ti Screw 			<p>EK Hex Abutments have Abutment Holding System at the bottom</p> <p>EK Non-Hex Abutments have three indents at the bottom</p>	
G/H	1.0		3.0	
Type	Hex	Non-Hex	Hex	Non-Hex
Ø4.0	EKNA4010TH	EKNA4010NTH	EKNA4030TH	EKNA4030NTH
Ø4.5	EKNA4510TH	EKNA4510NTH	EKNA4530TH	EKNA4530NTH

Temporary Abutment





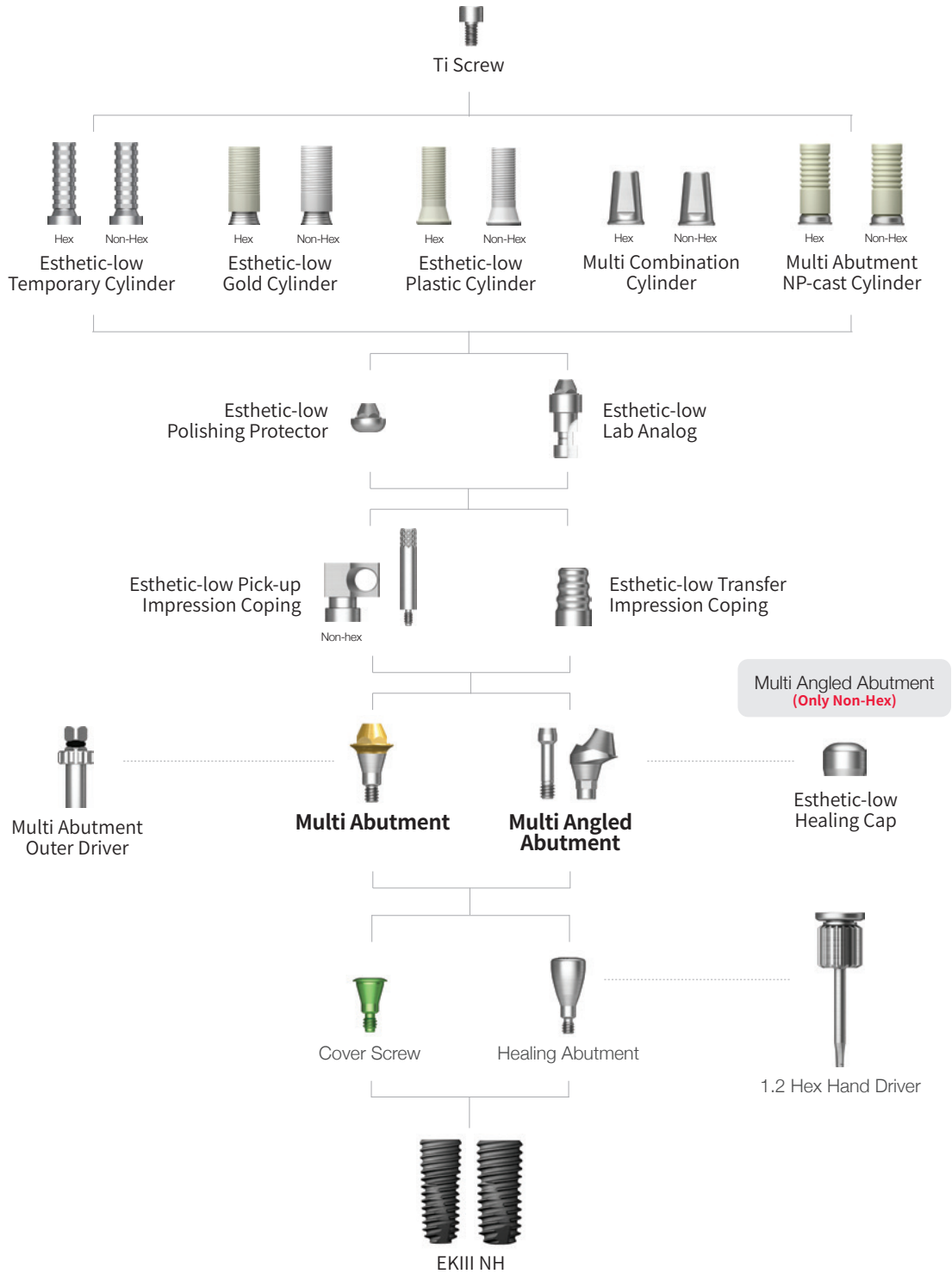

Temporary Abutment				
Description			Image/Guide	
<ul style="list-style-type: none"> • Cement/screw-retained temporary prosthesis • Utilized for producing provisional prosthesis after preparation • Implant level impression • Torque using 1.2 Hex Driver • Recommended Tightening Torque: 20Ncm • Packing unit: Abutment + Ti Screw <div style="display: flex; justify-content: space-around; align-items: center;"> <div style="text-align: center;">  <p>EK Hex Abutments have Abutment Holding System at the bottom</p> </div> <div style="text-align: center;">  <p>EK Non-Hex abutments have three indents at the bottom</p> </div> </div>				
G/H	1.0		3.0	
Type	Hex	Non-Hex	Hex	Non-Hex
				
Ø4.0	EKTTA4010TH	EKTTA4010NTH	EKTTA4030TH	EKTTA4030NTH
Ø4.5	EKTTA4510TH	EKTTA4510NTH	EKTTA4530TH	EKTTA4530NTH

Multi / Multi Angled

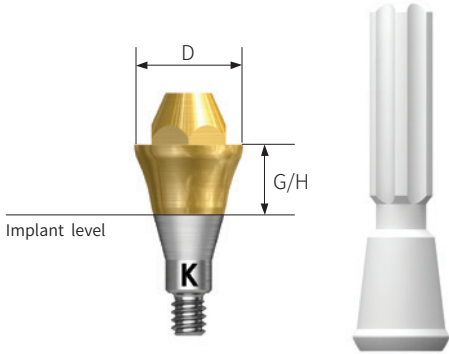







Abutment Level Impression

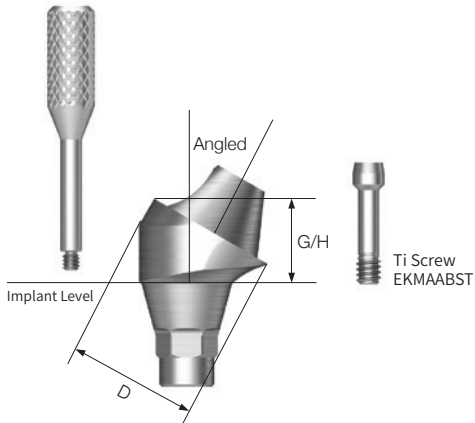

Multi Abutment

Multi Abutment					
Description		Image/Guide			
<ul style="list-style-type: none"> Screw-retained prosthesis Abutment designed for multiple prosthetic options Shares the same platform as the Multi Angled Abutment Restorative components: Esthetic-Low Cylinders (Hex/Non-Hex) The gingival height is 0.5mm higher when engaged in Ø3.5 implant Torque using Multi Abutment Outer Driver Pin-Type (MAODP) Rescue using Multi Abutment Outer Driver (HMAOD) Recommended tightening torque: 30Ncm Packing unit: Abutment + Carrier <p>※ Compatible with ET Multi (Esthetic-Low) components, please refer to page 72-73</p> <div style="text-align: center;">  <p>EK products are marked with "K".</p> </div>					
G/H	1.0	2.0	3.0	4.0	5.0
					
Ø4.8	EKMA5010P	EKMA5020P	EKMA5030P	EKMA5040P	EKMA5050P

Multi Angled Abutment

Multi Angled Abutment						
Description		Image/Guide				
<ul style="list-style-type: none"> Screw-retained prosthesis Abutment designed for multiple prosthetic options Shares the same platform as the Multi Abutment Restorative components: Esthetic-Low Cylinders (Hex/Non-Hex) The gingival height is 0.5mm higher when engaged in Ø3.5 implant Has dedicated abutment screw (EKMAABST) Torque using 1.2 Hex Hand Driver Recommended tightening torque: 30Ncm Packing unit: Abutment + Carrier <p>※ Compatible with ET Multi components, please refer to page 75</p>  <p>EK products have a cylinder at the bottom</p>						
Angle	17°			30°		
G/H	2.5	3.0	4.0	3.5	4.0	5.0
						
Ø4.8	EK17MA4820TH	EK17MA4830TH	EK17MA4840TH	EK30MA4830TH	EK30MA4840TH	EK30MA4850TH







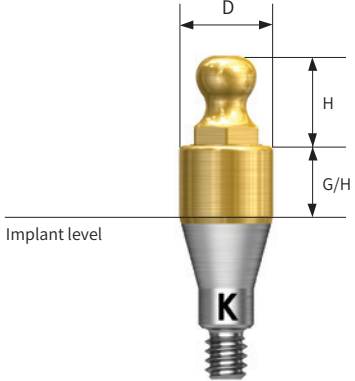

HIOSSSEN
IMPLANT

Stud/Locator®

Overdenture



Stud Abutment

Stud Abutment						
Description			Image/Guide			
<ul style="list-style-type: none"> • Overdenture prosthesis with O-ring system • Abutment designed to compensate up to 20° • Torque using O-ring driver (code: HAORD) • The gingival height is 0.5mm higher when engaged in Ø3.5 implant • Recommended tightening torque: 30Ncm • Ball head diameter • Normal size: Ø2.25 (H 3.4mm) <p>※ Compatible with ET O-ring components, please refer to page 77</p>						
 <p>EK products are marked with "K".</p>						
G/H	1.0	2.0	3.0	4.0	5.0	6.0
 <p>Ø3.5</p>						
Normal Size	EKSA3510	EKSA3520	EKSA3530	EKSA3540	EKSA3550	EKSA3560

Locator® Legacy Abutment

Locator® Legacy Abutment						
Description		Image/Guide				
<ul style="list-style-type: none"> Genuine Zest Dental Abutment 1.5mm lower profile with various attachments for stable retention force Torque using a Locator Outer Driver (code: TWLDSK/TWLDLK) Recommended tightening torque: 30Ncm <p>Locator Removable</p> <ul style="list-style-type: none"> Angle compensation up to 40° Customizable overdenture retention Self-aligning design <p>Locator Fixed</p> <ul style="list-style-type: none"> Permanent prosthesis solution Minimize friction on gum 						
G/H	1.0	2.0	3.0	4.0	5.0	6.0
Ø3.7	EKLCA0010	EKLCA0020	EKLCA0030	EKLCA0040	EKLCA0050	EKLCA0060

Locator® Male Processing Kit	
Description	Image/Item code
<ul style="list-style-type: none"> Components <ul style="list-style-type: none"> - Block out spacer/denture cap, black processing male - Replacement male blue/pink/clear A full range of retentive males are included with each denture cap to allow personalized retention for each specific patient Locator Core Tool places and removes nylon retentive males Packing unit: 2 sets 	<p>LMPS</p>

Locator® Replacement Male				
Description		approx. 6N	approx. 12N	approx. 22N
<ul style="list-style-type: none"> Angle compensation up to 20° Retention force: approx. 6N, 12N, 22N Packing unit: 4ea 				
		LRM06S	LRM12S	LRM22S

Locator® Extended Replacement Male				
Description	approx. 0N	approx. 6N	approx. 9N	approx. 12N
<ul style="list-style-type: none"> Angle compensation up to 20° Retention force: approx. 0N, 6N, 9N, 12N Packing unit: 4ea 				
		LEM00S	LEM06S	LRM09S

Locator® Legacy Abutment Components

Locator® Black Processing Male	
Description	Image/Item code
<ul style="list-style-type: none"> • A nylon male used in prosthesis fabrication process • Packing unit: 4ea 	
	LBPS

Locator® Impression Coping	
Description	Image/Item code
<ul style="list-style-type: none"> • A pick up impression coping • Closed tray • Packing unit: 4ea 	
	LICS

Locator® Block Out Spacers	
Description	Image/Item code
<ul style="list-style-type: none"> • Block-out spacers used on the heads of the Locator abutments. • Seals gap between denture cap and abutment • Packing unit: 20ea 	
	LBSS

Locator® Lab Analog			
Description			Image/Item code
<ul style="list-style-type: none"> • A lab analog for Locator abutment • Packing unit: 4ea 			
Ø3.35	Ø4.0	Ø5.0	
LAL30S	LAL40S	LAL50S	



Locator® Core Tool	
Description	Image/Item code
<ul style="list-style-type: none"> • Places and removes nylon retentive males in the denture cap • Divides into three separate tools: includes a hand driver for Locator abutment 	
	LCCT



Locator® Torque Driver		
Description	Short	Long
<ul style="list-style-type: none"> • Locator torque driver 		
	TWLDSK	TWLDLK

Locator® Scan Body		
Qty	Item code	Image
2 Pack	LOCSB2	
4 Pack	LOCSB4	
10 Pack	LOCSB10	

Locator® Legacy Abutment Components

Enhanced Locator® Core Tool	
Description	Image/item code
<ul style="list-style-type: none"> One streamlined tool compatible with Locator® Removable and Locator® FIXED Inserts Two-sided instrument designed for easy insertion and removal of any Locator® Insert <ul style="list-style-type: none"> Insertion Tip: Effortlessly pickup inserts for transfer and placement in housing Removal Tip: Place tip with closed prongs into insert, twist collet to open prongs, tilt core tool and easily remove and Locator® Insert 	<p style="text-align: center;">LECT</p>

Locator® FIXED Inserts					
Description	Image/Item code				
<p>Insert only</p> <ul style="list-style-type: none"> Used in 4 implant fixed, full-arch cases Cannot be used with Locator® FIXED Blue or Tan inserts Must be used with Gold Locator® FIXED housing One time use only 	 <table border="1" style="margin-left: auto; margin-right: auto;"> <tr> <td>2Pk</td> <td>LFGI2</td> </tr> <tr> <td>10Pk</td> <td>LFGI10</td> </tr> </table>	2Pk	LFGI2	10Pk	LFGI10
2Pk	LFGI2				
10Pk	LFGI10				
<p>Insert only</p> <ul style="list-style-type: none"> Used in combination with Locator® FIXED Tan anterior / posterior insert Must be used with Gold Locator® FIXED housing One time use only 	 <table border="1" style="margin-left: auto; margin-right: auto;"> <tr> <td>2Pk</td> <td>LFBI2</td> </tr> <tr> <td>10Pk</td> <td>LFBI10</td> </tr> </table>	2Pk	LFBI2	10Pk	LFBI10
2Pk	LFBI2				
10Pk	LFBI10				
<p>Insert only</p> <ul style="list-style-type: none"> Used in combination with Locator® FIXED Blue mid-arch insert Must be used with Gold Locator® FIXED housing One time use only 	 <table border="1" style="margin-left: auto; margin-right: auto;"> <tr> <td>2Pk</td> <td>LFI2</td> </tr> <tr> <td>10Pk</td> <td>LFTI10</td> </tr> </table>	2Pk	LFI2	10Pk	LFTI10
2Pk	LFI2				
10Pk	LFTI10				

Locator® FIXED Processing Package	
Description	Image/Item code
<p>Contains</p> <ul style="list-style-type: none"> 1 Gold Locator® FIXED Denture Housing 1 Green Locator® FIXED Insert 1 Locator® Processing Spacer 1 Locator® Black Processing Insert 	 <p style="text-align: center;">LFPG</p>
<p>Contains</p> <ul style="list-style-type: none"> 1 Gold Locator® FIXED Denture Housing 1 Blue Locator® FIXED Insert 1 Locator® Processing Spacer 1 Locator® Black Processing Insert 	 <p style="text-align: center;">LFPB</p>
<p>Contains</p> <ul style="list-style-type: none"> 1 Gold Locator® FIXED Denture Housing 1 Tan Locator® FIXED Insert 1 Locator® Processing Spacer 1 Locator® Black Processing Insert 	 <p style="text-align: center;">LFPT</p>

Locator® FIXED Housing Assembly					
Description	Image/Item code				
<ul style="list-style-type: none"> Gold Housing for Locator® FIXED Backward compatible and can be used with Locator® standard and extended inserts 	 <table border="1" style="margin-left: auto; margin-right: auto;"> <tr> <td>4Pk</td> <td>LFHA4</td> </tr> <tr> <td>10Pk</td> <td>LFHA10</td> </tr> </table>	4Pk	LFHA4	10Pk	LFHA10
4Pk	LFHA4				
10Pk	LFHA10				

Locator® Legacy Abutment Components

Locator® Fixed Seating and Removal Tool	
Description	Image/item code
<ul style="list-style-type: none"> • Includes: Tool, Seating Tip, Removal Tip, Wire and Level Wrench, and a Tip Wrench. • For seating and removing the prosthesis retained by the Locator® FIXED 	
	LFSRT

Locator® FIXED Seating Tip	
Description	Image/Item code
<ul style="list-style-type: none"> • Replacement seating tip for the Locator® FIXED Seating and Removal Tool. 	
	LFST

Locator® FIXED Removal Tip	
Description	Image/Item code
<ul style="list-style-type: none"> • Replacement removal tip for the Locator® FIXED Seating and Removal Tool. 	
	LFRT

Locator® FIXED Seating Tip Cushion	
Description	Image/Item code
<ul style="list-style-type: none"> • Replacement cushion block for the seating tip 	
	LFSTC

Locator® FIXED Removal Tip Wire Loop	
Description	Image/Item code
<ul style="list-style-type: none"> • Replacement wire loop for the removal tip 	
	LFRTWL

Locator® FIXED Tool 2.4mm Hex Wrench	
Description	Image/Item code
<ul style="list-style-type: none"> • Used to tighten or loosen the wire loop in the Locator® FIXED Removal Tip 	
	LFTHW

Locator® FIXED Optional Removal Hook Tip	
Description	Image/Item code
	
	LFORHT

Locator® FIXED Tool Tip Wrench	
Description	Image/Item code
<ul style="list-style-type: none"> • Tighten the seating or removal tip on the Locator® FIXED Seating and Removal tool from spinning 	
	LFTTW

Locator® FIXED Processing Component Storage Box	
Description	Image/Item code
<ul style="list-style-type: none"> • Improved Organization and Productivity • Easier Inventory Management 	
	LFPCSB

Locator® R-Tx Removable Attachment

EK R-Tx Locator® Abutment

Description

- Maintain overall user familiarity and processing techniques
- All-in-one packaging (Abutment, Denture Attachment Housing, Retention Inserts, Block-out Spacer)
- Angle correction up to 30°
- Easier retention terminology: zero, low, medium, high
- Replace the Legacy Locator® center cavity with a conventional .050"/1.25mm Hex Driver to seat abutment
- New DuraTec® coating (TiCN – Titanium Carbon Nitride) for greater wear resistance that is anodized pink for better aesthetics

※ Locator® R-Tx Processing Components, please refer to [page 79 - 81](#)

Image/Guide

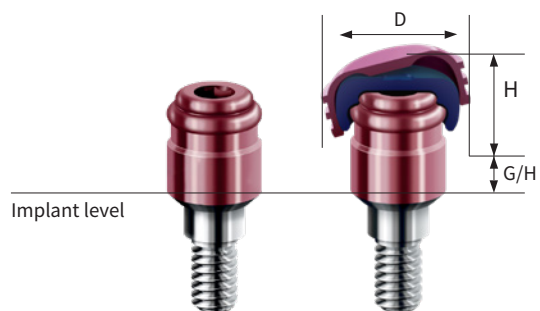

G/H	1.0	2.0	3.0	4.0	5.0	6.0
	REKLCA0010	REKLCA0020	REKLCA0030	REKLCA0040	REKLCA0050	REKLCA0060

HIOSSSEN
IMPLANT

HIOSSEN
IMPLANT



IMPLANT SYSTEM

IMPLANT

ET Implant System Intro	046
ET III Implant System	048
ET IV Implant System	049
Cover Screw	050
Healing Abutment	051

COMPONENTS

PROSTHETIC FLOW DIAGRAM 5	052
Rigid Abutment	053
PROSTHETIC FLOW DIAGRAM 6	058
Transfer Abutment	059
Angled Abutment	064
Freeform ST Abutment	065
Goldcast Abutment	066
NP-Cast Abutment	067
PROSTHETIC FLOW DIAGRAM 7	068
Quick Temporary Abutment	069
Temporary Abutment	069
PROSTHETIC FLOW DIAGRAM 8	070
Multi Abutment	071
Multi Angled Abutment	042
PROSTHETIC FLOW DIAGRAM 9	076
Stud Abutment	077
Locator® Legacy Abutment	078
Locator® R-TX Abutment	082

ET Design & Surface Feature

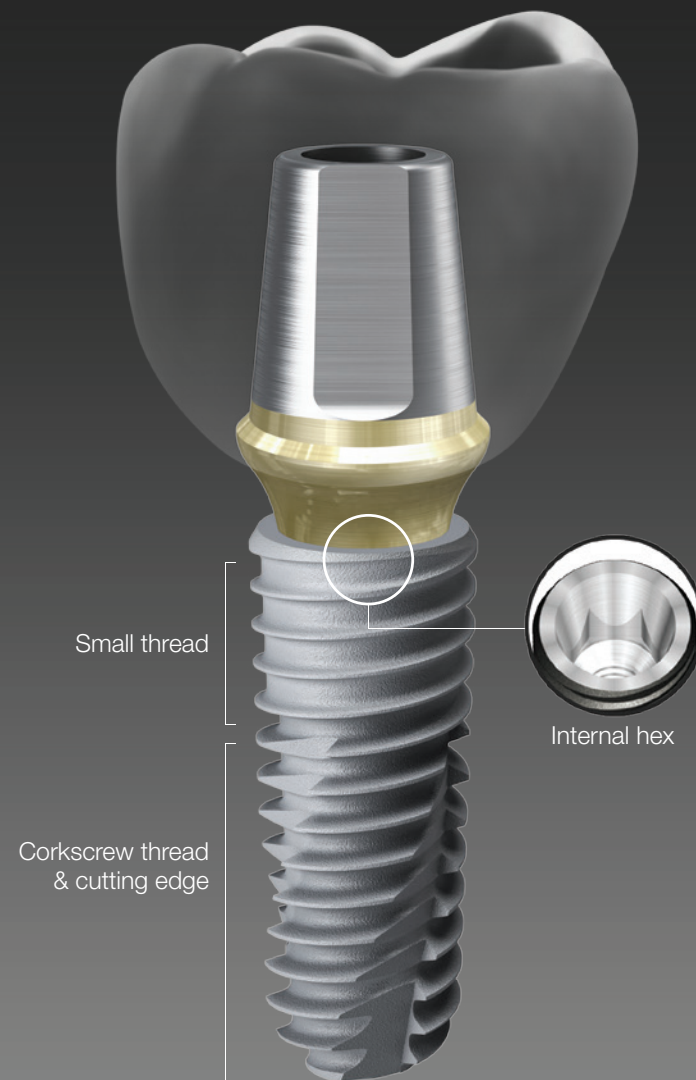

ET

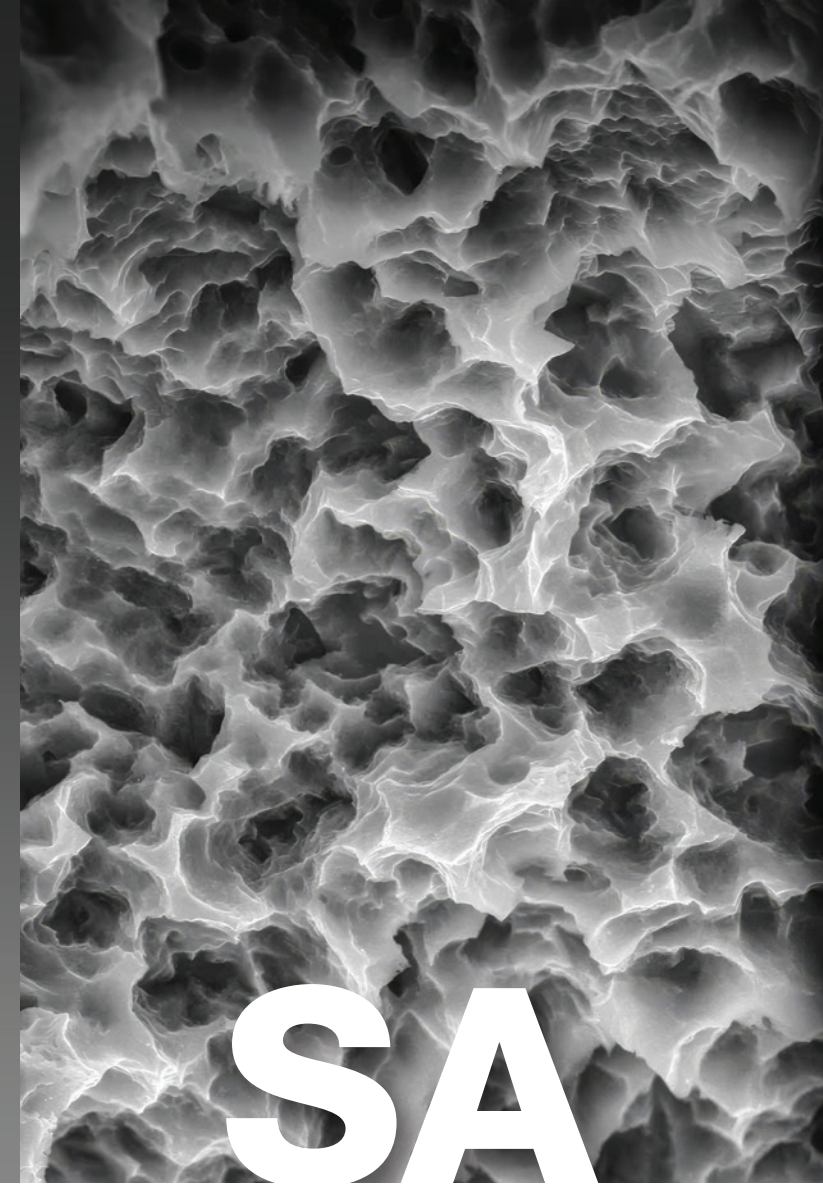

SA

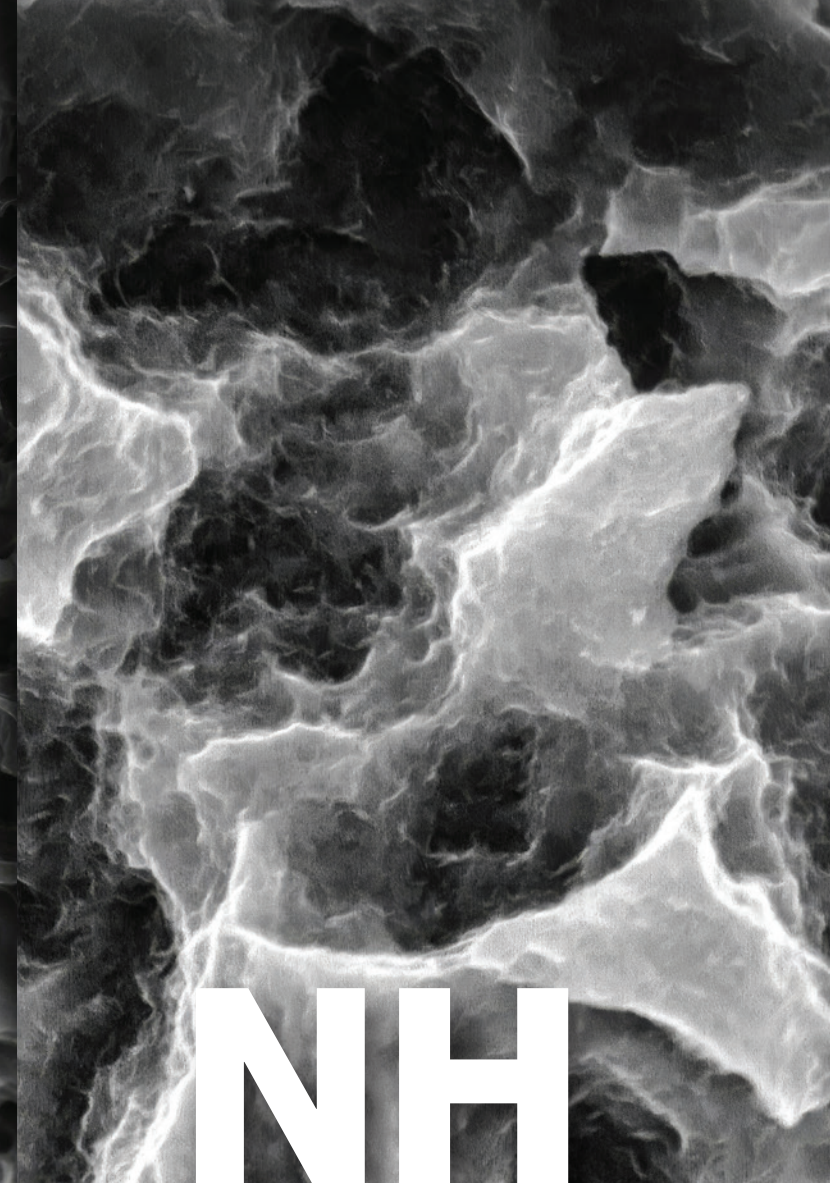

NH

Submerged type implant with an internal hex 11° tapered connection structure

- Connection - Mini / Regular
- Effect of improved initial stability in soft bone with smaller threads in the upper section
- Corkscrew thread & cutting edge
 - Superior self-threading effect for ease of placement path adjustment
 - Enhanced initial stability in soft bone and application of consistent placement torque according to the drill diameter
- Various body shape options available to match the patient's bone quality and clinical condition
 - ETIII (1.5° tapered body) Excellent initial stability needed for immediate loading even in soft bone
 - ETIV (6° tapered body) Specifically designed for use in maxillary sinus and soft bone, providing excellent initial stability
- Applicable surface types - SA / NH

Optimized surface morphology through acid-etching treatment

- Sand Blasted with Alumina and Acid-Etched
- Surface roughness: Ra 2.0-3.0 μm
(Note: the roughness in the upper 0.5mm part is Ra 0.5-0.6 μm)
- Uniform surface micro-pits of 1~3 μm
- Surface area increased by 46% compared to resorbable blast media (RBM) treated implants

In-vitro and In-vivo Bone Response

- Osteoblast differentiation and ossification improved by 20% compared to RBM-treated implants Initial bone response in a large animal model (mini-pig)
 - Initial stability (removal torque (RT), 4 weeks) improved by 48% compared to RBM-treated implants
 - Ossification (bone implant contact (BIC), 4 weeks) improved by 20% compared to RBM-treated implants

Low crystalline nano-HA coated SA surface

- Faster Bone Healing. Improved Osseointegration
- 10nm or less ultra-thin hydroxyapatite (HA) coating
- SA surface (Ra 2.0-3.0 μm) coated with HA
- Dual functions of titanium and HA
 - HA is naturally resorbed during ossification

In-vitro and In-vivo Bone Response

- Combination of advantages of both SA surfaces and HA
 - SA's ability to maintain the optimal surface morphology
 - HA's ability of high-quality bone formation even in bones of poor quality
- Ossification (BIC) improved by 40% compared to SA surfaces
- Applicable to all types of bone quality compared to HA

ET III Implant System

ET III Implant System	
Description	Guide
<ul style="list-style-type: none"> Bone level with 11° Morse taper internal hex connection Taper body with corkscrew thread design that acquires superior initial stability Narrow threads that increases self-tapping, path-correction and initial stability in soft bone Recommended implant placement torque: 40 Ncm or less Recommended implant size in posterior: Minimum Ø4.5mm <p>Narrow</p> <ul style="list-style-type: none"> Optimized for narrow ridge Compatible with Mini platform components (Excluded: Cover screw, Mount, Lab analog) <p>Ultra-wide</p> <ul style="list-style-type: none"> Optimized for posterior extraction and immediate placement, and replacement of failed implant case Apex design allows implant to achieve initial stability with immediate placement after extraction <div style="border: 1px solid gray; border-radius: 10px; padding: 10px; margin-top: 10px;"> <p>Order Code</p> <p>NoMount Implant: Code starts with "C"</p> <p>Mount Implant: Code starts with "A"</p> <p>ETNH: Code ends with "B"</p> <p>ETSA: Code ends with "S"</p> </div>	

Platform	Mini		Regular			Ultra-Wide		
Hex	Hex 2.1		Hex 2.5			Hex 2.5		
F	F3.2 - Narrow	F3.5	F4.0	F4.5	F5.0	F5.5	F6.0	F7.0
<div style="display: flex; flex-direction: column; align-items: center;"> <div style="background-color: #f4a460; border-radius: 50%; width: 20px; height: 20px; display: flex; align-items: center; justify-content: center; margin-bottom: 5px;">M</div> <div style="background-color: #4caf50; border-radius: 50%; width: 20px; height: 20px; display: flex; align-items: center; justify-content: center; margin-bottom: 5px;">R</div> <div style="background-color: #2196f3; border-radius: 50%; width: 20px; height: 20px; display: flex; align-items: center; justify-content: center; margin-bottom: 5px;">W</div> <div>L</div> </div>								
6mm (Short)	-	-	-	-	ET3R5006	ET3R5506	ET3R6006	ET3R7006
7mm	-	-	ET3R4007	ET3R4507	ET3R5007	ET3R5507	ET3R6007	ET3R7007
8.5mm	ET3M3008	ET3M3508	ET3R4008	ET3R4508	ET3R5008	ET3R5508	ET3R6008	ET3R7008
10mm	ET3M3010	ET3M3510	ET3R4010	ET3R4510	ET3R5010	ET3R5510	ET3R6010	ET3R7010
11.5mm	ET3M3011	ET3M3511	ET3R4011	ET3R4511	ET3R5011	ET3R5511	ET3R6011	ET3R7011
13 mm	ET3M3013	ET3M3513	ET3R4013	ET3R4513	ET3R5013	ET3R5513	ET3R6013	ET3R7013
15 mm	ET3M3015	ET3M3515	ET3R4015	ET3R4515	ET3R5015	-	-	-

※ For Ø3.2 implant, connection is 0.5mm shorter
 ※ Specifications are subject to change without any notice

ET IV Implant System

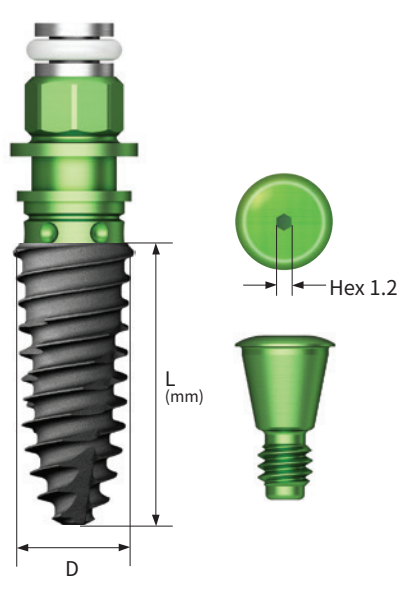
ET IV Implant System	
Description	Guide
<ul style="list-style-type: none"> Bone level with 11° Morse taper internal hex connection Ideal thread design for optimal osseointegration in maxillary sinus and/or soft bone Narrow corkscrew threads that increase self-tapping, path-correction, and initial stability in soft bone Sharp apex design stably secures the fixation in D4 bone Recommended implant placement torque: 40Ncm or less Recommended implant placement speed: 15rpm or less due to larger thread pitch size Recommended implant size in the posterior: Minimum Ø4.5mm <p>Narrow</p> <ul style="list-style-type: none"> Optimized for narrow ridge Compatible with Mini platform components (Excluding: Cover Screw, Implant Mount, and Lab Analog) <p>Ultra-wide</p> <ul style="list-style-type: none"> Optimized for posterior region extraction, immediate implant replacement, and failed implant replacement Apex design allows implant to achieve initial stability with immediate placement after extraction <div style="border: 1px solid gray; border-radius: 10px; padding: 10px; margin-top: 20px;"> <p>Order Code</p> <p>NoMount Implant: Code starts with "C"</p> <p>Mount Implant: Code starts with "A"</p> <p>ETNH: Code ends with "B"</p> <p>ETSA: Code ends with "S"</p> </div>	

Platform	Regular			Ultra-Wide	
Hex	Hex 2.5			Hex 2.5	
F	F4.0/Pitch 0.8	F4.5/Pitch 1.0	F5.0/Pitch 1.2	F6.0/Pitch 1.0	F7.0/Pitch 1.0
<div style="display: flex; flex-direction: column; align-items: center;"> <div style="display: flex; gap: 10px;"> <div style="border: 1px solid green; border-radius: 50%; width: 20px; height: 20px; display: flex; align-items: center; justify-content: center; color: white; font-weight: bold;">R</div> <div style="border: 1px solid blue; border-radius: 50%; width: 20px; height: 20px; display: flex; align-items: center; justify-content: center; color: white; font-weight: bold;">W</div> </div> <div style="margin-top: 10px;">L</div> </div>					
7.0 mm	ET4R4007	ET4R4507	ET4R5007	ET4R6007	ET4R7007
8.5 mm	ET4R4008	ET4R4508	ET4R5008	ET4R6008	ET4R7008
10 mm	ET4R4010	ET4R4510	ET4R5010	ET4R6010	ET4R7010
11.5 mm	ET4R4011	ET4R4511	ET4R5011	ET4R6011	ET4R7011
13 mm	ET4R4013	ET4R4513	ET4R5013	ET4R6013	ET4R7013

Cover Screw

Cover Screw	
Description	Image/Guide
<ul style="list-style-type: none"> Cover screw height (H) depends on the depth of implant placement Ø3.2 implants use exclusive cover screws Tighten with 1.2 Hex Hand Driver 	

Mini			
H	0.4	1.4	2.0
M P For Ø3.2			
	GSCS30	GSCS30M	GSCS30L

Mini			
H	0.4	1.4	2.0
M P			
	GSCS35	GSCS35M	GSCS35L

Regular			
H	0.4	1.4	2.0
R P			
	GSCS40S-G	GSCS40M-G	GSCS40L-G

Healing Abutment

Healing Abutment		Image/Guide				
Description		Image/Guide				
<ul style="list-style-type: none"> Mini platform prosthetic parts for Ø3.2 & Ø3.5 implants are yellow Tighten with 1.2 Hex Hand Driver 						
Reference table						
Healing abutment	H					
Abutment	G/H	1.0	2.0 or 3.0	3.0 or 4.0	5.0	
Impression coping	Type	Short	Short	Long	Long	

Mini						
H	3.0	4.0	5.0	6.0	7.0	9.0
M						
D						
Ø4.0	ETHLA4003M	ETHLA4004M	ETHLA4005M	ETHLA4006M	ETHLA4007M	ETHLA4009M
Ø4.5	ETHLA4503M	ETHLA4504M	ETHLA4505M	ETHLA4506M	ETHLA4507M	ETHLA4509M

Regular						
H	3.0	4.0	5.0	6.0	7.0	9.0
R						
D						
Ø4.0	ETHLA4003R	ETHLA4004R	ETHLA4005R	ETHLA4006R	ETHLA4007R	ETHLA4009R
Ø4.5	ETHLA4503R	ETHLA4504R	ETHLA4505R	ETHLA4506R	ETHLA4507R	ETHLA4509R
Ø5.0	ETHLA5003R	ETHLA5004R	ETHLA5005R	ETHLA5006R	ETHLA5007R	ETHLA5009R
Ø6.0	ETHLA6003R	ETHLA6004R	ETHLA6005R	ETHLA6006R	ETHLA6007R	ETHLA6009R
Ø7.0	ETHLA7003R	ETHLA7004R	ETHLA7005R	ETHLA7006R	ETHLA7007R	ETHLA7009R

※ ET 6.0mm and 9.0mm healing abutments are anticipated to be available soon.

Rigid

Abutment Level Impression

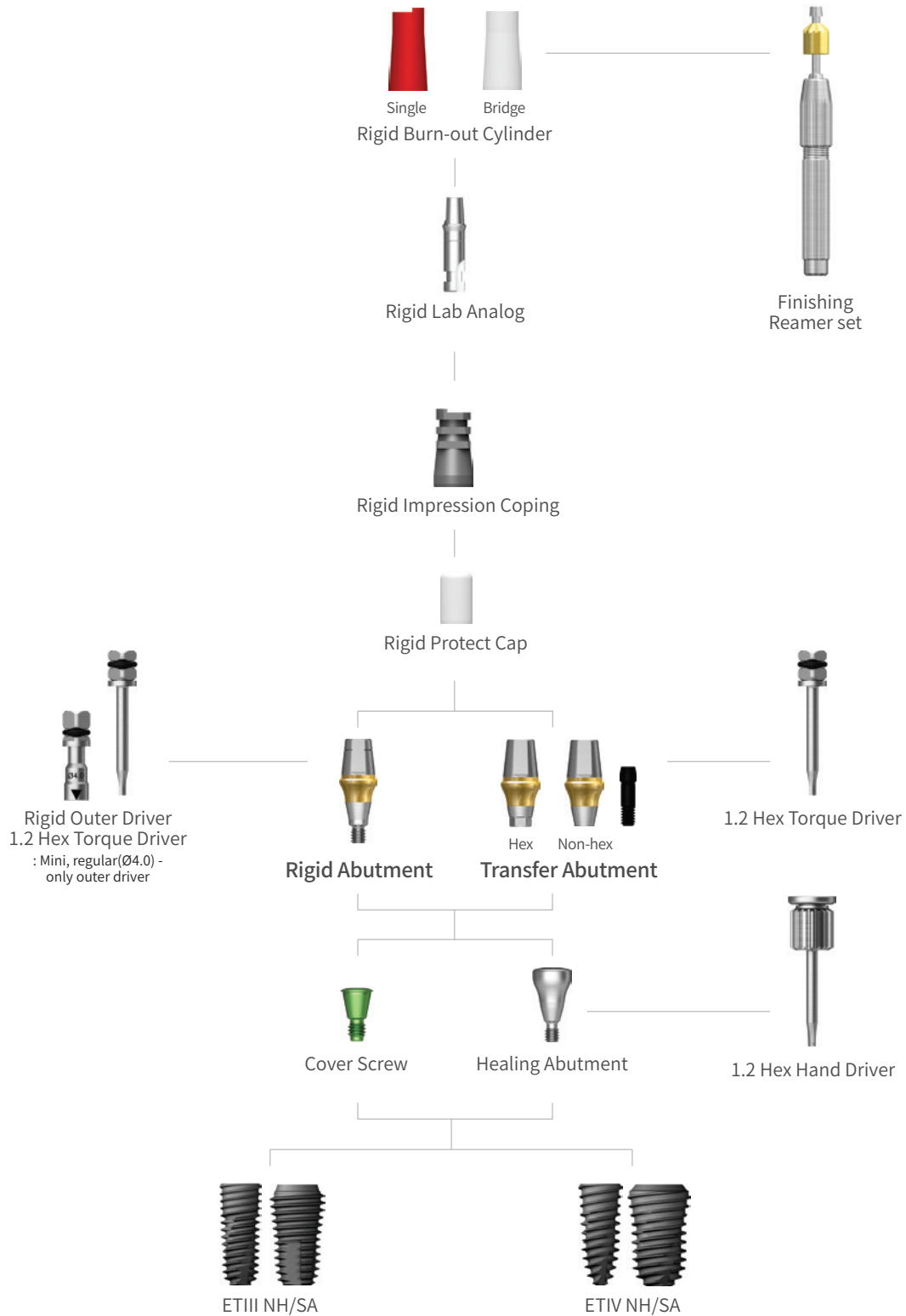





Rigid Abutment





Rigid Abutment	
Description	Image/Guide
<ul style="list-style-type: none"> • Cement-retained prosthesis • Abutment level impression • Ø4.0: torque with the outer driver (code: HORDML/HORDMS) • Ø4.5/5.0/6.0: torque with the outer driver or 1.2 hex driver • Ø7.0: torque with a 1.2 hex driver • Recommended tightening torque: 30Ncm • Packing unit: Abutment + Protect Cap 	





Mini Ø4.0						
H	1.0	2.0	3.0	4.0	5.0	
M						
D						
4.0	ETRGA4014MP	ETRGA4024MP	ETRGA4034MP	ETRGA4044MP	ETRGA4054MP	
5.5	ETRGA4015MP	ETRGA4025MP	ETRGA4035MP	ETRGA4045MP	ETRGA4055MP	
7.0	ETRGA4017MP	ETRGA4027MP	ETRGA4037MP	ETRGA4047MP	ETRGA4057MP	

Mini Ø4.5						
H	1.0	2.0	3.0	4.0	5.0	
M						
D						
4.0	ETRGA4514MP	ETRGA4524MP	ETRGA4534MP	ETRGA4544MP	ETRGA4554MP	
5.5	ETRGA4515MP	ETRGA4525MP	ETRGA4535MP	ETRGA4545MP	ETRGA4555MP	
7.0	ETRGA4517MP	ETRGA4527MP	ETRGA4537MP	ETRGA4547MP	ETRGA4557MP	





Rigid Abutment





Regular Ø4.0					
H	1.0	2.0	3.0	4.0	5.0
R					
D					
4.0	ETRGA4014SP	ETRGA4024SP	ETRGA4034SP	ETRGA4044SP	ETRGA4054SP
5.5	ETRGA4015SP	ETRGA4025SP	ETRGA4035SP	ETRGA4045SP	ETRGA4055SP
7.0	ETRGA4017SP	ETRGA4027SP	ETRGA4037SP	ETRGA4047SP	ETRGA4057SP

Regular Ø4.5					
H	1.0	2.0	3.0	4.0	5.0
R					
D					
4.0	ETRGA4514SP	ETRGA4524SP	ETRGA4534SP	ETRGA4544SP	ETRGA4554SP
5.5	ETRGA4515SP	ETRGA4525SP	ETRGA4535SP	ETRGA4545SP	ETRGA4555SP
7.0	ETRGA4517SP	ETRGA4527SP	ETRGA4537SP	ETRGA4547SP	ETRGA4557SP





Regular Ø5.0					
H	1.0	2.0	3.0	4.0	5.0
R					
D					
4.0	ETRGA5014SP	ETRGA5024SP	ETRGA5034SP	ETRGA5044SP	ETRGA5054SP
5.5	ETRGA5015SP	ETRGA5025SP	ETRGA5035SP	ETRGA5045SP	ETRGA5055SP
7.0	ETRGA5017SP	ETRGA5027SP	ETRGA5037SP	ETRGA5047SP	ETRGA5057SP





Rigid Abutment





Regular $\varnothing 6.0$						
H	1.0	2.0	3.0	4.0	5.0	
R						
D						
4.0	ETRGA6014SP	ETRGA6024SP	ETRGA6034SP	ETRGA6044SP	ETRGA6054SP	
5.5	ETRGA6015SP	ETRGA6025SP	ETRGA6035SP	ETRGA6045SP	ETRGA6055SP	
7.0	ETRGA6017SP	ETRGA6027SP	ETRGA6037SP	ETRGA6047SP	ETRGA6057SP	





Regular $\varnothing 7.0$						
G/H	1.0	2.0	3.0	4.0	5.0	
R						
H						
5.5	ETRGA7015SP	ETRGA7025SP	ETRGA7035SP	ETRGA7045SP	ETRGA7055SP	





Rigid Abutment Components

Rigid Protect Cap				
Description	H	4.0	5.5	7.0
<ul style="list-style-type: none"> Protects the rigid abutment until applying the final prosthesis Can be used as the base for a provisional crown Available for transfer abutment (Ø4.0 excluded) 	 Mini  Regular D			
	Ø4.0/Ø4.0	ETRPC4004	ETRPC4005	ETRPC4007
	Ø4.5/Ø4.5	ETRPC4504	ETRPC4505	ETRPC4507
	Ø5.0	ETRPC5004S	ETRPC5005S	ETRPC5007S
	Ø6.0	ETRPC6004S	ETRPC6005S	ETRPC6007S
	Ø7.0	-	ETRPC7005S	-

Rigid Retraction Cap				
Description	H	4.0	5.5	7.0
<ul style="list-style-type: none"> Used for accurate margin reproduction when taking a direct impression Can be used as the base for a provisional crown Available for transfer abutment (Ø4.0 excluded) 	 Mini  Regular D			
	Ø4.0/Ø4.0	ETRRC440	ETRRC460	ETRRC470
	Ø4.5/Ø4.5	ETRRC441	ETRRC461	ETRRC471
	Ø5.0	ETRRC540	ETRRC560	ETRRC570
	Ø6.0	ETRRC640	ETRRC660	ETRRC670
	Ø7.0	-	ETRRC760	-

Rigid Impression Coping				
Description	H	4.0	5.5	7.0
<ul style="list-style-type: none"> Impression components for rigid abutment Color coded by height Available for transfer abutment (Ø4.0 excluded) 	 Mini  Regular D			
	Ø4.0/Ø4.0	ETRIC4004S	ETRIC4005S	ETRIC4007S
	Ø4.5/Ø4.5	ETRIC4504S	ETRIC4505S	ETRIC4507S
	Ø5.0	ETRIC5004S	ETRIC5005S	ETRIC5007S
	Ø6.0	ETRIC6004S	ETRIC6005S	ETRIC6007S
	Ø7.0	-	ETRIC7005S	-

Rigid Burn-out Cylinder			
Description	H	Single	Bridge
<ul style="list-style-type: none"> Replacement for resin cap before wax up Delivery of perfect margin with proper fitting after casting 	 Mini  Regular D		
	Ø4.0/Ø4.0	ETRBC40S	ETRBC40B
	Ø4.5/Ø4.5	ETRBC45S	ETRBC45B
	Ø5.0	ETRBC50S	ETRBC50B
	Ø6.0	ETRBC60S	ETRBC60B
	Ø7.0	ETRBC70S	ETRBC70B

Rigid Lab Analog				
Description	H	4.0	5.5	7.0
<ul style="list-style-type: none"> Replicate of Rigid abutment for accurate orientation on model after impression Color coded by height 	 Mini  Regular D			
	Ø4.0/Ø4.0	ETRLA4004	ETRLA4005	ETRLA4007
	Ø4.5/Ø4.5	ETRLA4504	ETRLA4505	ETRLA4507
	Ø5.0	ETRLA5004S	ETRLA5005S	ETRLA5007S
	Ø6.0	ETRLA6004S	ETRLA6005S	ETRLA6007S
	Ø7.0	-	ETRLA7005S	-





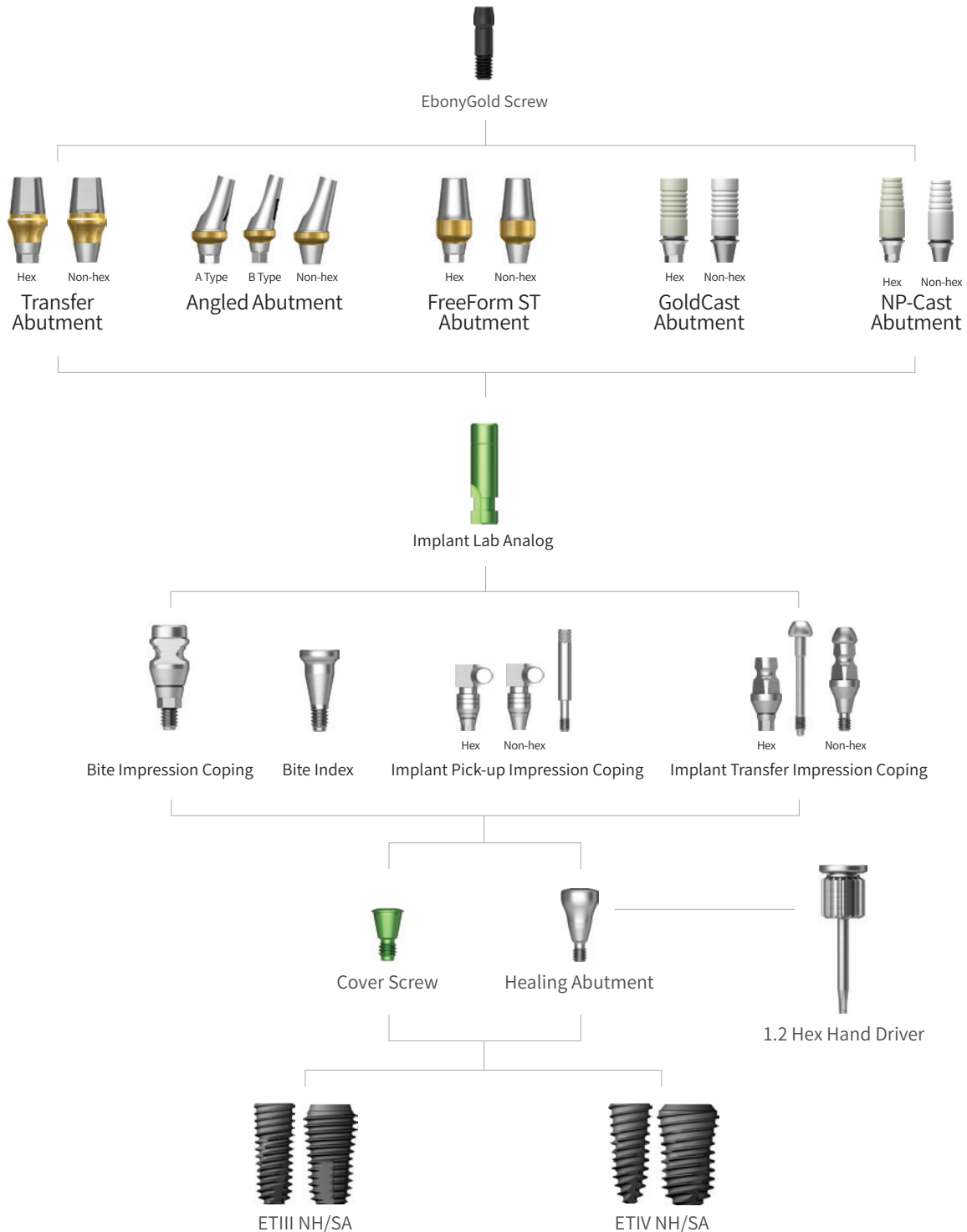



Transfer/Angled/ FreeForm ST GoldCast/NP-Cast

Abutment Level Impression











Transfer Abutment







Transfer Abutment	
Description	Image/Guide
<ul style="list-style-type: none"> • Cement-retained/combination prosthesis • Implant level impression • Abutment level impression is available using the rigid impression coping (Ø4.0 excluded) • Torque using 1.2 Hex Driver • Recommended tightening torque: <ul style="list-style-type: none"> - Mini: 20Ncm - Regular: 30Ncm • Packing unit: Abutment + EbonyGold Screw 	



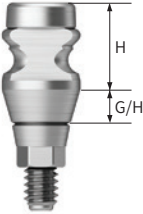

Mini Ø4.0								
G/H	1.0	2.0	3.0	4.0	5.0	6.0	7.0	
 H								
	Hex	5.5	ETTA4015MHW	ETTA4025MHW	ETTA4035MHW	ETTA4045MHW	ETTA4055MHW	ETTA4065MHW
	7.0	ETTA4017MHW	ETTA4027MHW	ETTA4037MHW	ETTA4047MHW	ETTA4057MHW	ETTA4067MHW	ETTA4077MHW
Non-Hex	5.5	ETTA4015MNW	ETTA4025MNW	ETTA4035MNW	ETTA4045MNW	ETTA4055MNW	ETTA4065MNW	ETTA4075MNW
	7.0	ETTA4017MNW	ETTA4027MNW	ETTA4037MNW	ETTA4047MNW	ETTA4057MNW	ETTA4067MNW	ETTA4077MNW
Mini Ø4.5								
Hex	5.5	ETTA4515MHW	ETTA4525MHW	ETTA4535MHW	ETTA4545MHW	ETTA4555MHW	ETTA4565MHW	ETTA4575MHW
	7.0	ETTA4517MHW	ETTA4527MHW	ETTA4537MHW	ETTA4547MHW	ETTA4557MHW	ETTA4567MHW	ETTA4577MHW
Non-Hex	5.5	ETTA4515MNW	ETTA4525MNW	ETTA4535MNW	ETTA4545MNW	ETTA4555MNW	ETTA4565MNW	ETTA4575MNW
	7.0	ETTA4517MNW	ETTA4527MNW	ETTA4537MNW	ETTA4547MNW	ETTA4557MNW	ETTA4567MNW	ETTA4577MNW







Transfer Abutment

Regular Ø4.5									
G/H		1.0	2.0	3.0	4.0	5.0	6.0	7.0	
 R H									
	Hex	5.5	ETTA4515SHW	ETTA4525SHW	ETTA4535SHW	ETTA4545SHW	ETTA4555SHW	ETTA4565SHW	ETTA4575SHW
	Hex	7.0	ETTA4517SHW	ETTA4527SHW	ETTA4537SHW	ETTA4547SHW	ETTA4557SHW	ETTA4567SHW	ETTA4577SHW
	Non-Hex	5.5	ETTA4515SNW	ETTA4525SNW	ETTA4535SNW	ETTA4545SNW	ETTA4555SNW	ETTA4565SNW	ETTA4575SNW
	Non-Hex	7.0	ETTA4517SNW	ETTA4527SNW	ETTA4537SNW	ETTA4547SNW	ETTA4557SNW	ETTA4567SNW	ETTA4577SNW
Regular Ø5.0									
	Hex	4.0	ETTA5014SHW	ETTA5024SHW	ETTA5034SHW	ETTA5044SHW	ETTA5054SHW	ETTA5064SHW	ETTA5074SHW
	Hex	5.5	ETTA5015SHW	ETTA5025SHW	ETTA5035SHW	ETTA5045SHW	ETTA5055SHW	ETTA5065SHW	ETTA5075SHW
	Hex	7.0	ETTA5017SHW	ETTA5027SHW	ETTA5037SHW	ETTA5047SHW	ETTA5057SHW	ETTA5067SHW	ETTA5077SHW
	Non-Hex	4.0	ETTA5014SNW	ETTA5024SNW	ETTA5034SNW	ETTA5044SNW	ETTA5054SNW	ETTA5064SNW	ETTA5074SNW
	Non-Hex	5.5	ETTA5015SNW	ETTA5025SNW	ETTA5035SNW	ETTA5045SNW	ETTA5055SNW	ETTA5065SNW	ETTA5075SNW
	Non-Hex	7.0	ETTA5017SNW	ETTA5027SNW	ETTA5037SNW	ETTA5047SNW	ETTA5057SNW	ETTA5067SNW	ETTA5077SNW
Regular Ø6.0									
	Hex	4.0	ETTA6014SHW	ETTA6024SHW	ETTA6034SHW	ETTA6044SHW	ETTA6054SHW	ETTA6064SHW	ETTA6074SHW
	Hex	5.5	ETTA6015SHW	ETTA6025SHW	ETTA6035SHW	ETTA6045SHW	ETTA6055SHW	ETTA6065SHW	ETTA6075SHW
	Hex	7.0	ETTA6017SHW	ETTA6027SHW	ETTA6037SHW	ETTA6047SHW	ETTA6057SHW	ETTA6067SHW	ETTA6077SHW
	Non-Hex	4.0	ETTA6014SNW	ETTA6024SNW	ETTA6034SNW	ETTA6044SNW	ETTA6054SNW	ETTA6064SNW	ETTA6074SNW
	Non-Hex	5.5	ETTA6015SNW	ETTA6025SNW	ETTA6035SNW	ETTA6045SNW	ETTA6055SNW	ETTA6065SNW	ETTA6075SNW
	Non-Hex	7.0	ETTA6017SNW	ETTA6027SNW	ETTA6037SNW	ETTA6047SNW	ETTA6057SNW	ETTA6067SNW	ETTA6077SNW
Regular Ø7.0									
	Hex	5.5	ETTA7015SHW	ETTA7025SHW	ETTA7035SHW	ETTA7045SHW	ETTA7055SHW	ETTA7065SHW	ETTA7075SHW
	Non-Hex	5.5	ETTA7015SNW	ETTA7025SNW	ETTA7035SNW	ETTA7045SNW	ETTA7055SNW	ETTA7065SNW	ETTA7075SNW











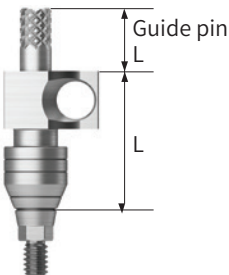

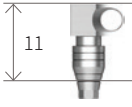
Transfer Abutment Components

Bite Impression Coping							
Description	G/H	2.0	3.0	4.0	5.0		
<ul style="list-style-type: none"> Designed for implant level impression 2-in-1 tool for bite registration and taking impression Utilizes same impression-taking technique when using Transfer Impression Coping Torque with Bite Impression Coping Driver (Mini: ETOICDM, Regular: ETOICDR) 	 						
		H					
	Ø4.0	5.0	ETBICM4420H	ETBICM4430H	ETBICM4440H	ETBICM4450H	
		7.0	ETBICM4620H	ETBICM4630H	ETBICM4640H	ETBICM4650H	
	Ø4.5	5.0	ETBICM4421H	ETBICM4431H	ETBICM4441H	ETBICM4451H	
		7.0	ETBICM4621H	ETBICM4631H	ETBICM4641H	ETBICM4651H	
	Ø4.5	5.0	ETBICR4421H	ETBICR4431H	ETBICR4441H	ETBICR4451H	
		7.0	ETBICR4621H	ETBICR4631H	ETBICR4641H	ETBICR4651H	
	Ø5.0	5.0	ETBICR5420H	ETBICR5430H	ETBICR5440H	ETBICR5450H	
		7.0	ETBICR5620H	ETBICR5630	ETBICR5640H	ETBICR5650H	



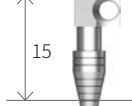



Bite Impression Coping Driver			
Description	Type	Mini	Regular
<ul style="list-style-type: none"> Used for tightening and removing Bite Impression Coping 	 Mini  Regular		
		ETOICDM	ETOICDR

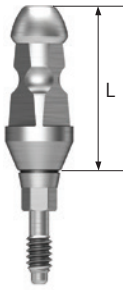

Bite Index							
Description	L	4.0	6.0	8.0	10.0	12.0	
<ul style="list-style-type: none"> Connected to the implant to check for bite impression Tighten with 1.2 Hex Hand Driver Packing unit: 2ea 	 						
		Ø4.5	ETBIM4504S	ETBIM4506S	ETBIM4508S	ETBIM4510S	ETBIM4512S
		Ø5.5	ETBIS5504S	ETBIS5506S	ETBIS5508S	ETBIS5510S	ETBIS5512S





Transfer Abutment Components

Implant Pick-up Impression Coping							
Description	L	11		0	5.0	9.0	
	Type	Hex	Non-Hex	Guide Pin			
<ul style="list-style-type: none"> • Components for Implant level impression with Open tray • Delivery of accurate internal hex position in the impression material • Tighten with a 1.2 hex hand driver • Packing unit: impression coping body + guide pin (*) 							
		11					
	Ø4.0	ETFPI4011MH	ETFPI4011MN		ETFPG00M	ETFPG05M*	ETFPG05ML*
	Ø4.5	ETFPI4511MH	ETFPI4511MN				
	Ø4.0	ETFPI4011SH	ETFPI4011SN				
	Ø4.5	ETFPI4511SH	ETFPI4511SN				
	Ø5.0	ETFPI5011SH	ETFPI5011SN		ETFPG00S	ETFPG05S*	ETFPG05SL
	Ø6.0	ETFPI6011SH	ETFPI6011SN				
	Ø7.0	ETFPI7011SH	ETFPI7011SN				
	L	15		0	5.0	9.0	
	Type	Hex	Non-Hex	Guide Pin			
							
		15					
	Ø4.0	ETFPI4015MH	ETFPI4015MN		ETFPG00ML	ETFPG05ML*	ETFPG10ML*
Ø4.5	ETFPI4515MH	ETFPI4515MN					
Ø4.0	ETFPI4015SH	ETFPI4015SN					
Ø4.5	ETFPI4515SH	ETFPI4515SN					
Ø5.0	ETFPI5015SH	ETFPI5015SN		ETFPG00SL	ETFPG05SL*	ETFPG10SL	
Ø6.0	ETFPI6015SH	ETFPI6015SN					
Ø7.0	ETFPI7015SH	ETFPI7015SN					

Transfer Abutment Components

Implant Transfer Impression Coping					
Description	L	11		14	
	Type	Hex	Non-Hex	Hex	Non-Hex
<ul style="list-style-type: none"> Components for implant level impression Closed Tray impression Features a triangular arc structure for precise repositioning Tighten with 1.2 Hex Hand Driver Packing unit: <ul style="list-style-type: none"> - Hex: Impression coping body + guide pin - Non-Hex: Impression coping body 					
	Ø4.0	ETFTI4011MH	ETFTI4011MN	ETFTI4014MH	ETFTI4014MN
	Ø4.5	ETFTI4511MH	ETFTI4511MN	ETFTI4514MH	ETFTI4514MN
	Ø4.0	ETFTI4011SH	ETFTI4011SN	ETFTI4014SH	ETFTI4014SN
	Ø4.5	ETFTI4511SH	ETFTI4511SN	ETFTI4514SH	ETFTI4514SN
	Ø5.0	ETFTI5011SH	ETFTI5011SN	ETFTI5014SH	ETFTI5014SN
	Ø6.0	ETFTI6011SH	ETFTI6011SN	ETFTI6014SH	ETFTI6014SN
	Ø7.0	ETFTI7011SH	ETFTI7011SN	ETFTI7014S	ETFTI7014SN

Laboratory Screw			
Description	Type	Lab Screw	Waxing Screw
<ul style="list-style-type: none"> Lab screw: abutment screw for lab work Waxing screw: longer screw for making screw-type prosthesis and transfer jigs Packing unit: lab screw, waxing screw 			
	Mini	ETABSML	ETABSMW
	Regular	ETABSSL	ETABSSW

Implant Lab Analog				
Description		Ø3.2	Mini	Regular
<ul style="list-style-type: none"> Lab analog for implant level impressions Select appropriate size according to the implant size 				
		ETFLAM3	ETFLAM	ETFLAS

Angled Abutment

Angled Abutment						
Description		Image/Guide				
<ul style="list-style-type: none"> Cement-retained/combination prosthesis Abutment designed to compensate up to 23° without removal Suitable for implant level impression Torque using 1.2 Hex Driver Recommended tightening torque: <ul style="list-style-type: none"> Mini: 20Ncm Regular: 30Ncm Packing unit: Abutment + EbonyGold Screw 						
G/H	2.0			4.0		
Type	Hex A	Hex B	Non-Hex	Hex A	Hex B	Non-Hex
M Mini R Regular						
Ø4.0	ETAGA432MAW	ETAGA432MBW	ETAGA432MNW	ETAGA434MAW	ETAGA434MBW	ETAGA434MNW
Ø4.5	ETAGA452MAW	ETAGA452MBW	ETAGA452MNW	ETAGA454MAW	ETAGA454MBW	ETAGA454MNW
Ø4.5	ETAGA452SAW	ETAGA452SBW	ETAGA452SNW	ETAGA454SAW	ETAGA454SBW	ETAGA454SNW
Ø5.0	ETAGA552SAW	ETAGA552SBW	ETAGA552SNW	ETAGA554SAW	ETAGA554SBW	ETAGA554SNW
Ø6.0	ETAGA602SAW	ETAGA602SBW	ETAGA602SNW	ETAGA604SAW	ETAGA604SBW	ETAGA604SNW

FreeForm ST Abutment

FreeForm ST Abutment					
Description		Image/Guide			
<ul style="list-style-type: none"> Cement-retained/combination prosthesis Utilized to modify contour of abutment margins Suitable for implant level impression Torque using 1.2 Hex Driver Recommended tightening torque: <ul style="list-style-type: none"> - Mini: 20Ncm - Regular: 30Ncm Packing unit: Abutment + EbonyGold Screw 					
G/H		1.5		3.0	
Type		Hex	Non-Hex	Hex	Non-Hex
Mini					
Ø4.0		ETFSA401MHW	ETFSA401MNW	ETFSA403MHW	ETFSA403MNW
G/H		2.0		4.0	
Type		Hex A	Non-Hex	Hex A	Non-Hex
Regular					
Ø4.0		ETFSA401SHW	ETFSA401SNW	ETFSA403SHW	ETFSA403SNW
Ø5.0		ETFSA501SHW	ETFSA501SNW	ETFSA503SHW	ETFSA503SNW
Ø5.0 (Straight)		ETFSA501SHW	ETFSA501SNW	ETFSA503SHW	ETFSA503SNW
Ø6.0		ETFSA601SHW	ETFSA601SNW	ETFSA603SHW	ETFSA603SNW
Ø7.0		ETFSA701SHW	ETFSA701SNW	ETFSA703SHW	ETFSA703SNW

GoldCast Abutment

GoldCast Abutment				
Description			Image/Guide	
<ul style="list-style-type: none"> • Cement-retained/combination prosthesis • Abutment used to produce customized prosthesis through gold alloy casting • Melting temperature of abutment: 1,400 ~1,450°C (2,552~2,822°F) • Suitable for implant level impression • Torque using 1.2 Hex Driver • Recommended tightening torque: <ul style="list-style-type: none"> - Mini: 20Ncm - Regular: 30Ncm • Packing Unit: Abutment + EbonyGold Screw 			<p>The diagram shows a GoldCast Abutment with a diameter 'D' and a height of 10 units. It is shown in relation to an 'Implant level' and a 'G/H' dimension. To the right, an 'EbonyGold screw' is shown with 'Mini' and 'Regular' variants, corresponding to part numbers 'ETABSM' and 'ETABSS' respectively.</p>	
G/H	1.0		3.0	
Type	Hex	Non-Hex	Hex	Non-Hex
Mini Regular				
Ø4.0	ETGCA401MHW	ETGCA401MNW	ETGCA403MHW	ETGCA403MNW
Ø4.5	ETGCA451SHW	ETGCA451SNW	ETGCA453SHW	ETGCA453SNW

NP-Cast Abutment







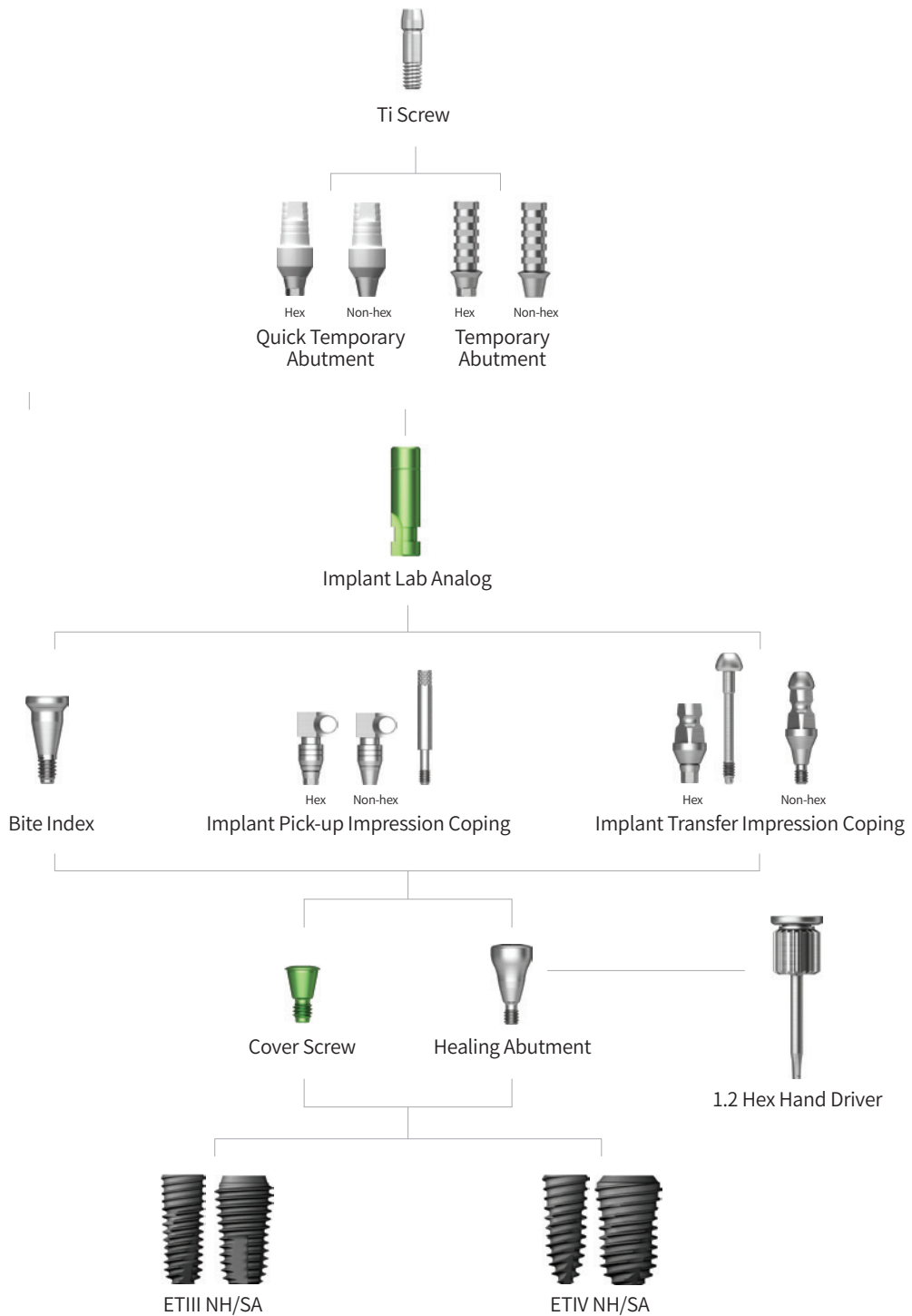

NP-Cast Abutment				
Description			Image/Guide	
<ul style="list-style-type: none"> • Cement-retained/combination prosthesis • Abutment used to produce customized prosthesis through non-precious alloy • Melting temperature of abutment: 1,400 ~1,450°C (2,552~2,822°F) • Suitable for implant level impression • Torque using 1.2 Hex Driver • Recommended tightening torque: <ul style="list-style-type: none"> - Mini: 20Ncm - Regular: 30Ncm • Packing Unit: Abutment + EbonyGold Screw 				
G/H	1.0		3.0	
Type	Hex	Non-Hex	Hex	Non-Hex
<div style="display: flex; flex-direction: column; gap: 5px;"> <div style="display: flex; align-items: center;"> M Mini </div> <div style="display: flex; align-items: center;"> R Regular </div> </div>				
Ø4.0	ETNCA401MHW	ETNCA401MNW	ETNCA403MHW	ETNCA403MNW
Ø4.5	ETNCA451SHW	ETNCA451SNW	ETNCA453SHW	ETNCA453SNW

Temporary/Quick Temporary







Abutment Level Impression



Quick Temporary Abutment

Quick Temporary Abutment			
Description	G/H	1.5	
	Type	Hex	Non-Hex
<ul style="list-style-type: none"> Cement/screw-retained type prosthesis A provisional prosthesis used for immediate loading Easy to prep or add resin Torque using a 1.2 hex driver Recommended tightening torque: 20Ncm(mini/regular) Packing unit: Abutment + Ti screw  <p>Ti screw Mini ETABSMT Regular ETABSST</p>	 Mini  Regular		
	Ø4.0	ETQTA401MHT	ETQTA401MNT
	Ø4.5	ETQTA451RHT	ETQTA451RNT
	G/H	5.0	
	Type	Hex	Non-Hex
	 Mini  Regular		
	Ø4.0	ETQTA405MHT	ETQTA405MNT
	Ø4.5	ETQTA455MHT	ETQTA455MNT
	Ø4.5	ETQTA455RHT	ETQTA455RNT
	Ø5.5	ETQTA555RHT	ETQTA555RNT

Temporary Abutment

Temporary Abutment					
Description	G/H	1.0		3.0	
	Type	Hex	Non-Hex	Hex	Non-Hex
<ul style="list-style-type: none"> Cement/screw-retained temporary prosthesis Utilized for producing temporary prosthesis after prep Implant level impression Torque using 1.2 Hex Driver Recommended tightening torque: 20Ncm (Mini + Regular) Packing unit: Abutment + Ti screw  <p>Ti screw Mini ETABSMT Regular ETABSST</p>	 Mini  Regular				
	Ø4.0	ETTPA401MHT	ETTPA401MNT	ETTPA403MHT	ETTPA403MNT
	Ø4.5	ETTPA451SHT	ETTPA451SNT	ETTPA453SHT	ETTPA453SNT

Multi/Multi Angled

Abutment Level Impression

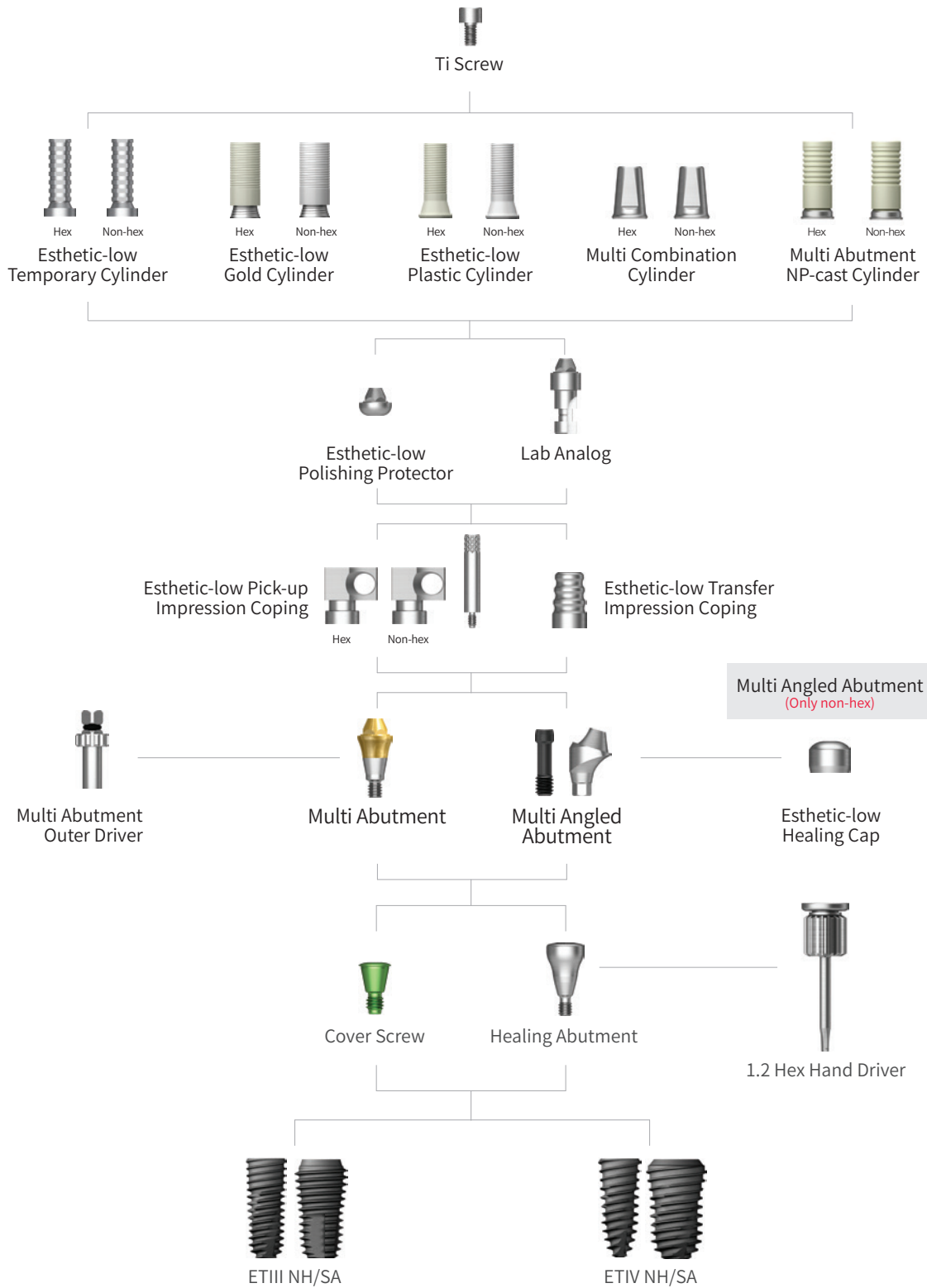



Multi Abutment

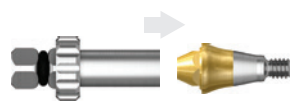

Multi Abutment						
Description				Image/Guide		
<ul style="list-style-type: none"> Screw-retained prosthesis Abutment designed for multiple prosthetic options Shares the same platform as the Multi Angled Abutment Restorative components: Esthetic-Low Cylinders (Hex/Non-Hex) Torque using Multi Abutment Outer Driver Pin-Type (MAODP) Rescue using Multi Abutment Outer Driver (HMAOD) Recommended tightening torque: 30Ncm (Mini + Regular) Packing unit: Abutment + Carrier 						
G/H	1.0	2.0	3.0	4.0	5.0	
Mini Regular						
Ø4.8	ETMTA501M	ETMTA502M	ETMTA503M	ETMTA504M	ETMTA505M	
Ø4.8	ETMTA501R	ETMTA502R	ETMTA503R	ETMTA504R	ETMTA505R	

Multi Abutment Components

Multi Abutment Outer Driver		
Description	Item code	Image
<ul style="list-style-type: none"> Multi Abutment Torque Driver Pin Type: for all standard cases Rescue Type: for cases with broken abutment screw 	MAODP	

Multi Abutment Machine Driver		
Description	Item code	Image
<ul style="list-style-type: none"> Machine driver for multi abutment 	HMAMD	



Multi Combination Cylinder			
Description		Hex	Non-Hex
<ul style="list-style-type: none"> Component for Multi Abutment Used for producing combination prosthesis Non-Hex can be utilized for Multi Angled Abutment Torque using 1.2 Hex Driver Recommended tightening torque: 20Ncm Packing unit: Cylinder + Ti Cylinder Screw 			
		ETMC500TH	ETMC500NTH

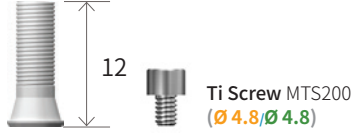

Multi Abutment NP Cast Cylinder			
Description		Hex	Non-Hex
<ul style="list-style-type: none"> Component for Multi Abutment Used for producing combination prosthesis Non-Hex can be utilized for Multi Angled Abutment Torque using 1.2 Hex Driver Recommended tightening torque: 20Ncm Packing unit: Cylinder + Ti Cylinder Screw 			
		ETMNCA500TH	ETMNCA500NTH





Esthetic-low Gold Cylinder		
Description	Type	Non-Hex
<ul style="list-style-type: none"> Screw-retained prosthesis Cast with gold alloys Cylinder melting point: 1,400°~1,450°C (2,552°F~2,642°F) Torque using 1.2 Hex Driver Recommended tightening torque: 20Ncm Packing unit: Cylinder + Ti Cylinder Screw 	<p>M Mini</p> <p>R Regular</p>	 <p>Ti Screw MTS200 (Ø 4.8/Ø 4.8)</p>
		Ø4.8/Ø4.8

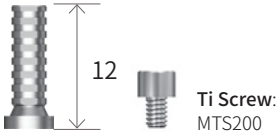

Esthetic-low Plastic Cylinder		
Description	Type	Non-Hex
<ul style="list-style-type: none"> Cast with non-precious metal alloys Torque using a 1.2 hex driver Recommended tightening torque: 20Ncm Packing unit: cylinder + Ti cylinder screw 	<p>M Mini</p> <p>R Regular</p>	 <p>Ti Screw MTS200 (Ø 4.8/Ø 4.8)</p>
		Ø4.8/Ø4.8



Multi Abutment Components



Esthetic-low Healing Cap		
Description	H	6.0
<ul style="list-style-type: none"> Protect Cap Tighten with 1.2 Hex Hand Driver 	 Mini  Regular	 MHCR100
	Ø4.8/Ø4.8	

Esthetic-low Narrow Temporary Cylinder		
Description	Type	Non-Hex
Narrow Type <ul style="list-style-type: none"> Used in fabricating temporary prosthesis (Ti- Gr-3) Torque using 1.2 Hex Driver Recommended tightening torque: 20Ncm Packing unit: Cylinder + Ti cylinder screw 	 Mini  Regular	 12 Ti Screw: MTS200 NMTR100TH
	Ø4.8/Ø4.8	

Esthetic-low Pick-up Impression Coping			
Description	Type	Non-Hex	Guide Pin 15
<ul style="list-style-type: none"> Component for Multi Abutment Impression Coping for Esthetic-low Abutment Implant level impression Tighten with 1.2 Hex Hand Driver Packing unit: Impression coping body + Guide Pin(*) ※ standard guide pin length 	 Mini  Regular	 MSR100	 GP150*
	Ø4.8/Ø4.8		

Esthetic-low Transfer Impression Coping		
Description	H	8.0
<ul style="list-style-type: none"> Component for Multi Abutment Impression coping for Esthetic-low Abutment Attach with 1.2 Hex Hand Driver 	 Mini  Regular	 MTTR100
	Ø4.8/Ø4.8	

Esthetic-low Lab Analog		
Description		Image/Item code
<ul style="list-style-type: none"> Component for Multi Abutment Lab Analog for Esthetic-Low Abutment Attach with 1.2 Hex Hand Driver 	 Mini  Regular	 MERR300
	Ø4.8/Ø4.8	

Esthetic-low Polishing Protector		
Description		Image/Item code
<ul style="list-style-type: none"> Protecting GoldCast/Plastic Cylinder joints during the polishing process Tighten with 1.2 Hex Hand Driver 	 Mini  Regular	 MPCR100
	Ø4.8/Ø4.8	

Multi Angled Abutment

Multi Angled Abutment							
Description				Image/Guide			
<ul style="list-style-type: none"> Screw-retained prosthesis Abutment designed for multiple prosthetic options Shares the same platform as the Multi Abutment Restorative components: Esthetic-Low Cylinders (Regular/Non-Hex) Has dedicated abutment screw (Mini: ETMABSM/Regular: ETMABSS) Torque using 1.2 Hex Hand Driver Recommended tightening torque: <ul style="list-style-type: none"> Mini: 20Ncm Regular: 30Ncm Packing unit: Abutment + EbonyGold Screw 							
Angle	17°				30°		
G/H	2.5	3.0	4.0	5.0	3.5	4.0	5.0
Mini Regular							
Ø4.8	ETMA217MHW	ETMA317MHW	ETMA417MHW	-	ETMA330MHW	ETMA430MHW	ETMA530MHW
Ø4.8	ETMA217SHW	ETMA317SHW	ETMA417SHW	ETMA517SHW	ETMA330SHW	ETMA430SHW	ETMA530SHW

Multi Ti-Base			
Description		Image/Guide	
<ul style="list-style-type: none"> Utilized for combination prosthesis for multiple prosthetics Can be used with Multi Scan Body and Digital Library Non-Hex type only Torque using 1.2 Hex Driver Recommended tightening torque: 20Ncm Packing unit: Multi Ti-Base + Multi Ti-Base Screw 			
Angle	5°		10°
H	4	6	4
	TSMTB0405GTH	TSMTB0605GTH	TSMTB0410GTH

ET Multi Scan Body	
Description	Image/Item code
<ul style="list-style-type: none"> Used by attaching to ET Multi Abutment for intra oral scanning Non-Hex type Torque using 1.2 Hex Driver 	
	TSMSBC

Stud/Locator®

Overdenture

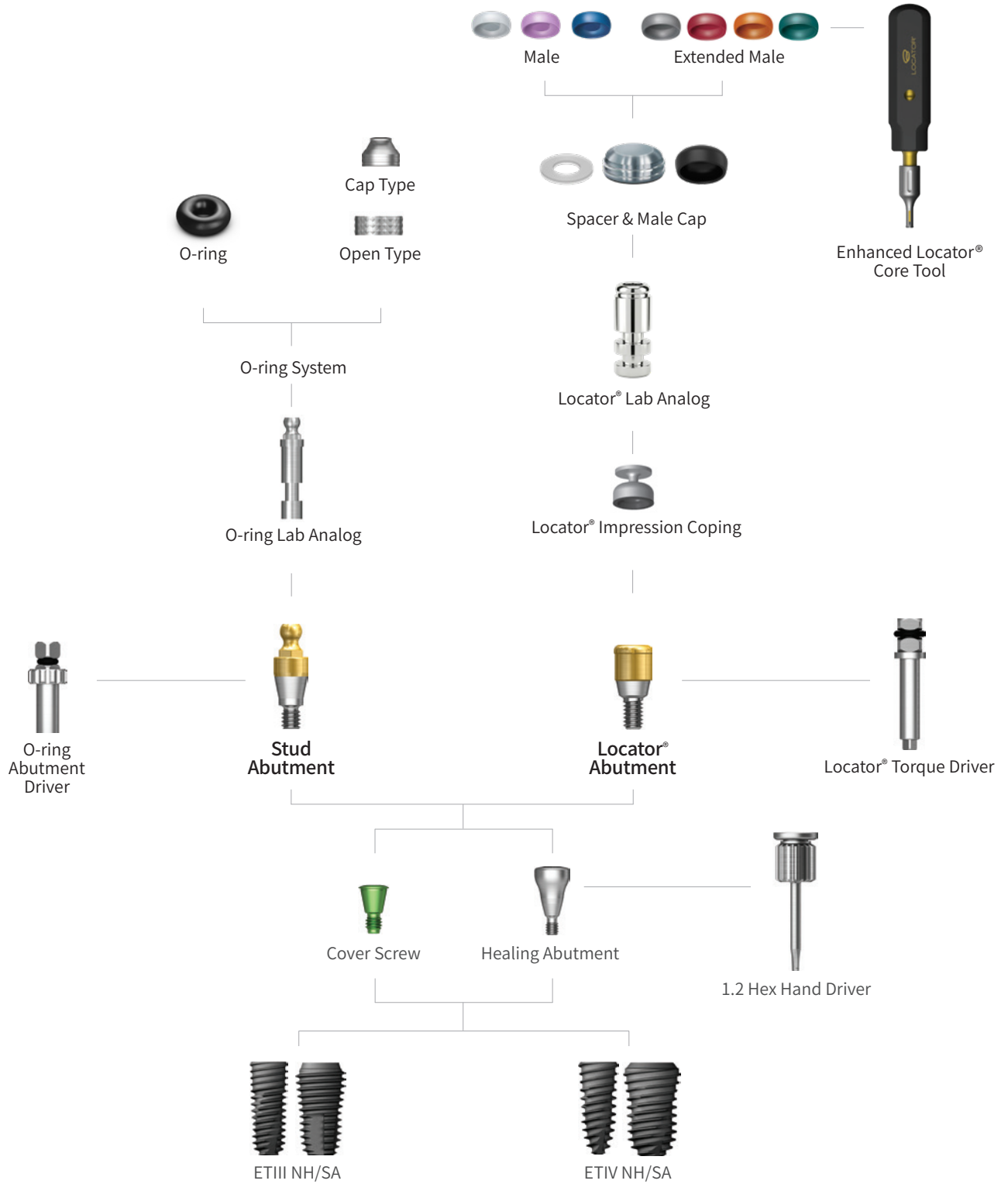

Stud Abutment

Stud Abutment						
Description				Image/Guide		
<ul style="list-style-type: none"> Overdenture prosthesis with O-ring system Abutment designed to compensate up to 20° Torque using O-ring driver (code: HAORD) Recommended tightening torque: 30Ncm Ball head diameter <ul style="list-style-type: none"> - Normal size: $\varnothing 2.25$ (H 3.4mm) 						
G/H	1.0	2.0	3.0	4.0	5.0	6.0
M Mini R Regular Normal size						
Ø3.5	ETSAO351M	ETSAO352M	ETSAO353M	ETSAO354M	ETSAO355M	ETSAO356M
Ø3.5	ETSAO351S	ETSAO352S	ETSAO353S	ETSAO354S	ETSAO355S	ETSAO356S

Components

O-ring Retainer Cap Set	
Description	Image/Item code
<ul style="list-style-type: none"> O-ring housing Place an appropriate O-ring in the metal housing before connecting to the abutment Packing unit: Retainer cap + O-ring 	
	ET RCS01

O-ring Set	
Description	Image/Item code
<ul style="list-style-type: none"> O-ring set Packing unit: O-ring x 5ea 	
	ETO AON01

O-ring Retainer Set	
Description	Image/Item code
<ul style="list-style-type: none"> O-ring housing Used when vertical height is shorter than the retainer cap Packing unit: Retainer + O-ring 	
	ET RS01

O-ring Lab Analog (Denture)	
Description	Image/Item code
<ul style="list-style-type: none"> Lab analog for stud abutment 	
	ETO AL

Locator® Legacy Abutment

Locator® Legacy Abutment						
Description		Image/Guide				
<ul style="list-style-type: none"> Genuine Zest Dental Abutment 1.5mm lower profile with various attachments for stable retention force Torque using a Locator Outer Driver (code: TWLDSK/TWLDLK) Recommended tightening torque: 30Ncm <p>Locator Removable</p> <ul style="list-style-type: none"> Angle compensation up to 40° Customizable overdenture retention Self-aligning design <p>Locator Fixed</p> <ul style="list-style-type: none"> Permanent prosthesis solution Minimize friction on gum 						
G/H	1.0	2.0	3.0	4.0	5.0	6.0
Mini Regular						
Ø3.7	HGLCA3510M	HGLCA3520M	HGLCA3530M	HGLCA3540M	HGLCA3550M	HGLCA3560M
Ø3.7	HGLCA4010S	HGLCA4020S	HGLCA4030S	HGLCA4040S	HGLCA4050S	HGLCA4060S

Locator® Male Processing Kit	
Description	Image/Item code
<ul style="list-style-type: none"> Components <ul style="list-style-type: none"> Block out spacer/denture cap, black processing male Replacement male blue/pink/clear A full range of retentive males are included with each denture cap to allow personalized retention for each specific patient Locator Core Tool places and removes nylon retentive males Packing unit: 2 sets 	<p>LMPS</p>

Locator® Replacement Male				
Description		approx. 6N	approx. 12N	approx. 22N
<ul style="list-style-type: none"> Angle compensation up to 20° Retention force: approx. 6N, 12N, 22N Packing unit: 4ea 				
		LRM06S	LRM12S	LRM22S

Locator® Extended Replacement Male				
Description	approx. 0N	approx. 6N	approx. 9N	approx. 12N
<ul style="list-style-type: none"> Angle compensation up to 20° Retention force: approx. 0N, 6N, 9N, 12N Packing unit: 4ea 				
		LEM00S	LEM06S	LRM09S

Locator® Legacy Abutment Components



Locator® Black Processing Male	
Description	Image/Item code
<ul style="list-style-type: none"> • A nylon male used in prosthesis fabrication process • Packing unit: 4ea 	
	LBPS

Locator® Impression Coping	
Description	Image/Item code
<ul style="list-style-type: none"> • A pick up impression coping • Closed tray • Packing unit: 4ea 	
	LICS

Locator® Block Out Spacers	
Description	Image/Item code
<ul style="list-style-type: none"> • Block-out spacers used on the heads of the Locator abutments. • Seals gap between denture cap and abutment • Packing unit: 20ea 	
	LBSS

Locator® Lab Analog			
Description			Image/Item code
<ul style="list-style-type: none"> • A lab analog for Locator abutment • Packing unit: 4ea 			
Ø3.35	Ø4.0	Ø5.0	
LAL30S	LAL40S	LAL50S	



Locator® Core Tool	
Description	Image/Item code
<ul style="list-style-type: none"> • Places and removes nylon retentive males in the denture cap • Divides into three separate tools: includes a hand driver for Locator abutment 	
	LCCT

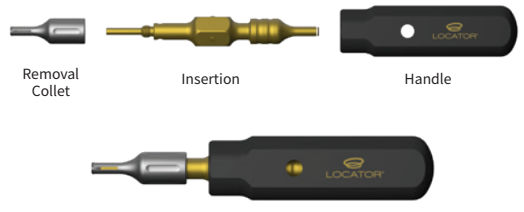

Locator® Torque Driver		
Description	Short	Long
<ul style="list-style-type: none"> • Locator torque driver 		
	TWLDSK	TWLDLK

Locator® Scan Body		
Qty	Item code	Image
2 Pack	LOCSB2	
4 Pack	LOCSB4	
10 Pack	LOCSB10	

Locator® Legacy Abutment Components

Enhanced Locator® Core Tool	
Description	Image/item code
<ul style="list-style-type: none"> One streamlined tool compatible with Locator® Removable and Locator® FIXED Inserts Two-sided instrument designed for easy insertion and removal of any Locator® Insert <ul style="list-style-type: none"> Insertion Tip: Effortlessly pickup inserts for transfer and placement in housing Removal Tip: Place tip with closed prongs into insert, twist collet to open prongs, tilt core tool and easily remove and Locator® Insert 	 <p style="text-align: center;">LECT</p>

Locator® FIXED Inserts					
Description	Image/Item code				
<p>Insert only</p> <ul style="list-style-type: none"> Used in 4 implant fixed, full-arch cases Cannot be used with Locator® FIXED Blue or Tan inserts Must be used with Gold Locator® FIXED housing One time use only 	 <table border="1"> <tr> <td>2Pk</td> <td>LFGI2</td> </tr> <tr> <td>10Pk</td> <td>LFGI10</td> </tr> </table>	2Pk	LFGI2	10Pk	LFGI10
2Pk	LFGI2				
10Pk	LFGI10				
<p>Insert only</p> <ul style="list-style-type: none"> Used in combination with Locator® FIXED Tan anterior / posterior insert Must be used with Gold Locator® FIXED housing One time use only 	 <table border="1"> <tr> <td>2Pk</td> <td>LFBI2</td> </tr> <tr> <td>10Pk</td> <td>LFBI10</td> </tr> </table>	2Pk	LFBI2	10Pk	LFBI10
2Pk	LFBI2				
10Pk	LFBI10				
<p>Insert only</p> <ul style="list-style-type: none"> Used in combination with Locator® FIXED Blue mid-arch insert Must be used with Gold Locator® FIXED housing One time use only 	 <table border="1"> <tr> <td>2Pk</td> <td>LF12</td> </tr> <tr> <td>10Pk</td> <td>LFT110</td> </tr> </table>	2Pk	LF12	10Pk	LFT110
2Pk	LF12				
10Pk	LFT110				

Locator® FIXED Processing Package	
Description	Image/Item code
<p>Contains</p> <ul style="list-style-type: none"> 1 Gold Locator® FIXED Denture Housing 1 Green Locator® FIXED Insert 1 Locator® Processing Spacer 1 Locator® Black Processing Insert 	 <p style="text-align: center;">LFGP</p>
<p>Contains</p> <ul style="list-style-type: none"> 1 Gold Locator® FIXED Denture Housing 1 Blue Locator® FIXED Insert 1 Locator® Processing Spacer 1 Locator® Black Processing Insert 	 <p style="text-align: center;">LFPB</p>
<p>Contains</p> <ul style="list-style-type: none"> 1 Gold Locator® FIXED Denture Housing 1 Tan Locator® FIXED Insert 1 Locator® Processing Spacer 1 Locator® Black Processing Insert 	 <p style="text-align: center;">LFPT</p>

Locator® FIXED Housing Assembly					
Description	Image/Item code				
<ul style="list-style-type: none"> Gold Housing for Locator® FIXED Backward compatible and can be used with Locator® standard and extended inserts 	 <table border="1"> <tr> <td>4Pk</td> <td>LFHA4</td> </tr> <tr> <td>10Pk</td> <td>LFHA10</td> </tr> </table>	4Pk	LFHA4	10Pk	LFHA10
4Pk	LFHA4				
10Pk	LFHA10				

Locator® Legacy Abutment Components

Locator® Fixed Seating and Removal Tool	
Description	Image/item code
<ul style="list-style-type: none"> • Includes: Tool, Seating Tip, Removal Tip, Wire and Level Wrench, and a Tip Wrench. • For seating and removing the prosthesis retained by the Locator® FIXED 	
	LFSRT

Locator® FIXED Seating Tip	
Description	Image/Item code
<ul style="list-style-type: none"> • Replacement seating tip for the Locator® FIXED Seating and Removal Tool. 	
	LFST

Locator® FIXED Removal Tip	
Description	Image/Item code
<ul style="list-style-type: none"> • Replacement removal tip for the Locator® FIXED Seating and Removal Tool. 	
	LFRT

Locator® FIXED Seating Tip Cushion	
Description	Image/Item code
<ul style="list-style-type: none"> • Replacement cushion block for the seating tip 	
	LFSTC

Locator® FIXED Removal Tip Wire Loop	
Description	Image/Item code
<ul style="list-style-type: none"> • Replacement wire loop for the removal tip 	
	LFRTWL

Locator® FIXED Tool 2.4mm Hex Wrench	
Description	Image/Item code
<ul style="list-style-type: none"> • Used to tighten or loosen the wire loop in the Locator® FIXED Removal Tip 	
	LFTHW

Locator® FIXED Optional Removal Hook Tip	
Description	Image/Item code
	
	LFORHT



Locator® FIXED Tool Tip Wrench	
Description	Image/Item code
<ul style="list-style-type: none"> • Tighten the seating or removal tip on the Locator® FIXED Seating and Removal tool from spinning 	
	LFTTW

Locator® FIXED Processing Component Storage Box	
Description	Image/Item code
<ul style="list-style-type: none"> • Improved Organization and Productivity • Easier Inventory Management 	
	LFPCSB

Locator® R-Tx Removable Attachment

R-Tx Abutment							
Description				Image/Guide			
<ul style="list-style-type: none"> • Maintain overall user familiarity and processing techniques • All-in-one packaging (Abutment, Denture Attachment Housing, Retention Inserts, Block-out Spacer) • Angle correction up to 30° • Easier retention terminology: zero, low, medium, high • Replace the Legacy Locator® center cavity with a conventional .050"/1.25mm Hex Driver to seat abutment • New DuraTec® coating (TiCN – Titanium Carbon Nitride) for greater wear resistance that is anodized pink for better aesthetics 							
G/H	1.0	2.0	3.0	4.0	5.0	6.0	
M Mini R Regular Normal size							
Ø3.5	RHGLCA3510MA	RHGLCA3520MA	RHGLCA3530MA	RHGLCA3540MA	RHGLCA3550MA	RHGLCA3560MA	
Ø4.0	RHGLCA4010SA	RHGLCA4020SA	RHGLCA4030SA	RHGLCA4040SA	RHGLCA4050SA	RHGLCA4060SA	

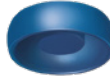
Locator[®] R-Tx Processing Components

Retention Insert				
Description	Zero	Low	Medium	High
<ul style="list-style-type: none"> Nylon Inserts pivot within the Denture Attachment Housing during the insertion and removal of the overdenture Packing unit: 4ea 				
	RLRMZS	RLRMLS	RLRMMS	RLRMHS

Processing Spacer	
Description	Image/Item code
<ul style="list-style-type: none"> Creates a recess in the overdenture Allows the Denture Attachment Housing to be seated without any interference Along with the surrounding overdenture acrylic. 	
	RLAPSS

Abutment Analog			
Description	3.35	4.0	5.0
<ul style="list-style-type: none"> Inserted into the Impression Coping Packaged in three dimensions to accommodate smaller and larger sized implants 			
	RLAL30S	RLAL40S	RLAL50S

Block Out Spacers	
Description	Image/Item code
<ul style="list-style-type: none"> Blocks out undercut areas immediately Surrounds the abutment Keeps the rim of the Denture Attachment Housing clean during the pick-up 	
	RLBSS

Impression Coping	
Description	Image/Item code
<ul style="list-style-type: none"> Used to transfer the position of the abutment from the mouth into the model 	
	RLICS





Locator [®] R-Tx Scan Body		
Qty	Item code	Image
2 Pack	LOCRSB2	
4 Pack	LOCRSB4	
10 Pack	LOCRSB10	

Locator® Processing Components

Denture Attachment Processing Assembly	
Description	Image/Item code
<ul style="list-style-type: none"> Permanently attached into the overdenture allowing the Retention Inserts to pivot during insertion and removal Packing unit: 4ea 	
	RLDAPAS

Processing Insert	
Description	Image/Item code
<ul style="list-style-type: none"> The pre-inserted Black Processing Insert is used during the pick-up and try-in processes Packing unit: 4ea 	
	RLBPS

R-Tx Retention Insert Tool	
Description	Image/Item code
<ul style="list-style-type: none"> Used only for insertion and removal of the Locator R-Tx Retention and Processing Inserts 	
	LCCT

CHAIRSIDE® Attachment Processing Material		
Description	Type	Image/Item code
<ul style="list-style-type: none"> Designed for ease of use and predictability when processing attachments into full and partial overdentures, using either a chairside or laboratory procedure 	4mL Syringe <ul style="list-style-type: none"> 4ml Syringe and Plunger Mixing tip: 15ea Angled Tip: 15ea 	 <p>4mL Syringe and Plunger</p>  <p>Mixing Tips (15)</p>  <p>Angled Tips (15)</p>
	CSPM8	
	18mL Cartridge <ul style="list-style-type: none"> 18ml Cartridge Mixing Tips: 10ea 	 <p>18mL Cartridge</p>  <p>Mixing Tips (10)</p>
	CSPM18	

HIOSSEN
IMPLANT

HIOSSEN
IMPLANT

SS

IMPLANT SYSTEM

IMPLANT

SS Implant System	012
Healing Abutment / Mount & Screw	014

COMPONENTS

PROSTHETIC FLOW DIAGRAM 10	038
Solid Abutment	040
Excellent Solid Abutment	041
PROSTHETIC FLOW DIAGRAM 11	042
ComOcta Abutment	043
ComOcta Plus Abutment	044
PROSTHETIC FLOW DIAGRAM 12	045
Octa Abutment	050
PROSTHETIC FLOW DIAGRAM 13	051
O-ring Abutment	056

SS Design & Surface Feature

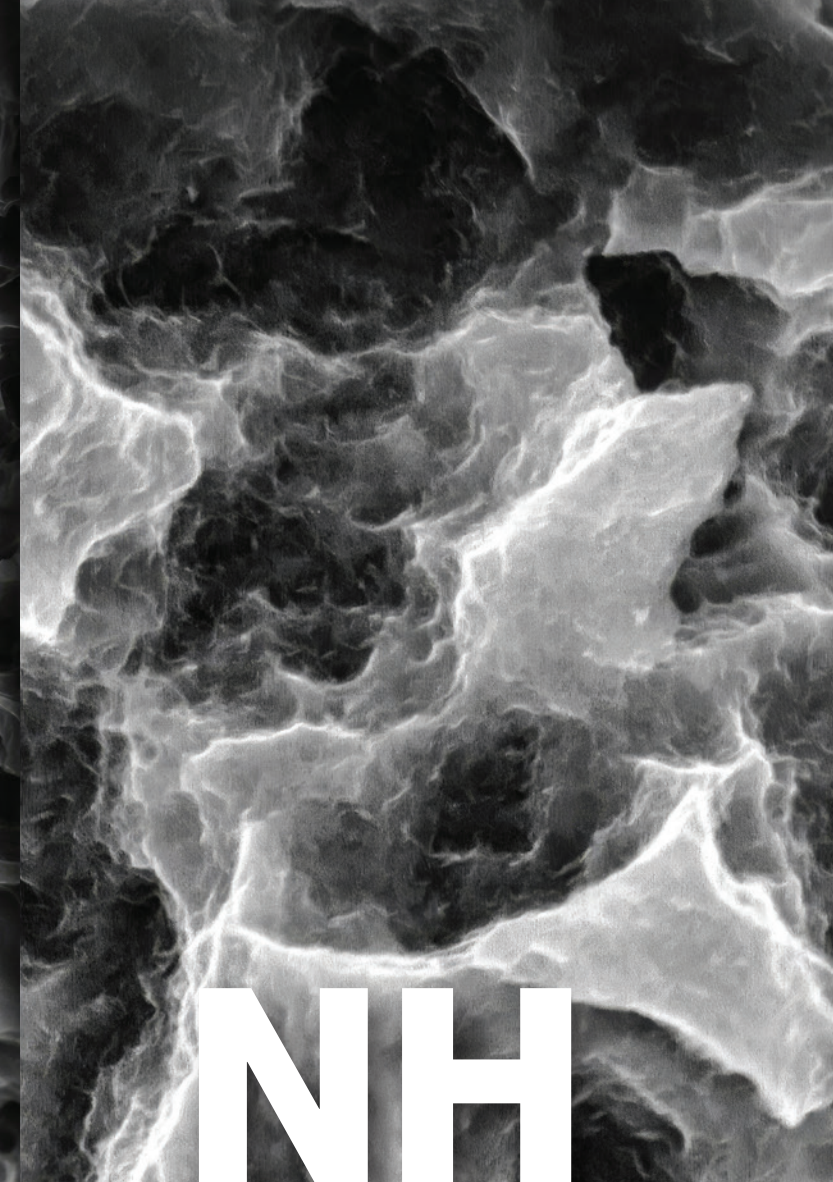
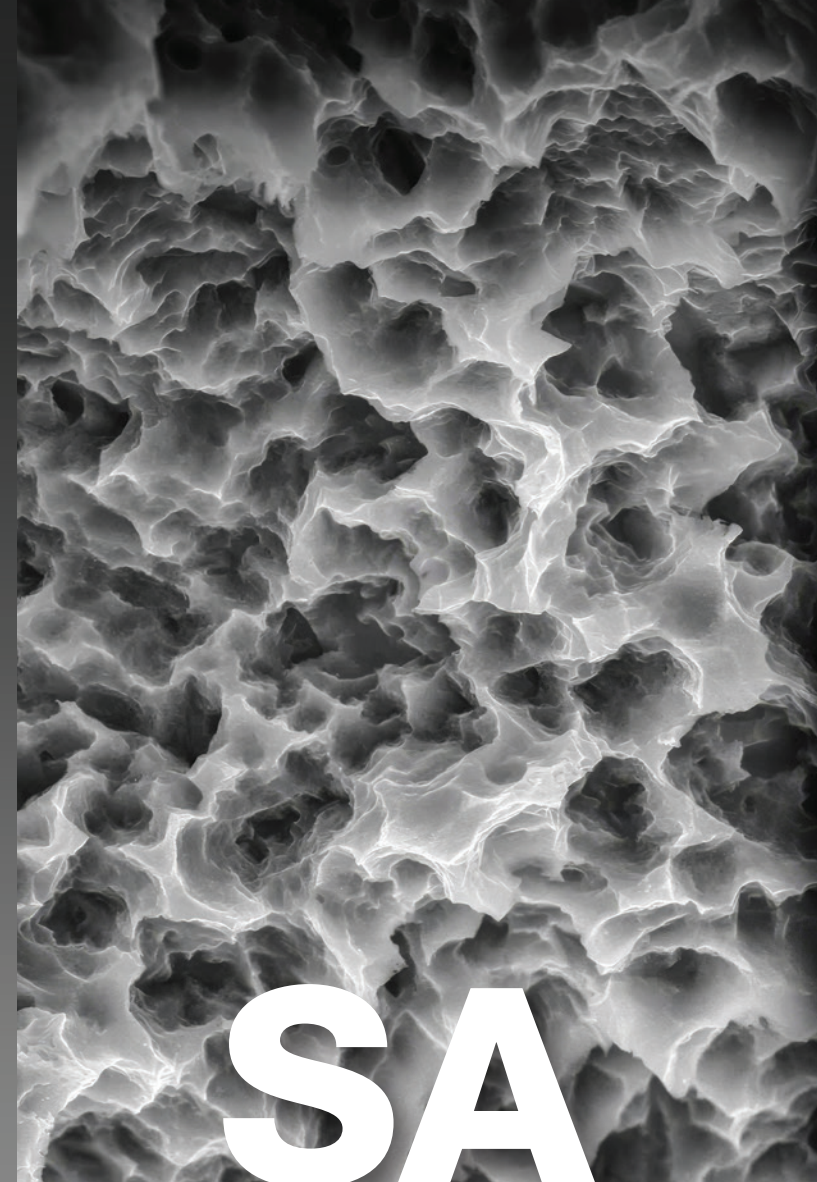

Non-submerged type implant with an internal octa 8° tapered connection based on the 1st stage surgery

- Connection - **Regular / Wide**
- Corkscrew thread & cutting edge
 - Superior self-threading effect for ease of placement path adjustment
 - Enhanced initial stability in soft bone and application of consistent placement torque according to the drill diameter
- Various body shape options available to match the patient's bone quality and clinical condition
 - SSII (straight body): Ease of placement depth adjustment
 - SSIII (1.5° tapered body): Excellent initial stability needed for immediate loading even in soft bone
- Applicable surface types - SA / NH

Optimized surface morphology through acid-etching treatment

- Sand Blasted with Alumina and Acid-Etched
- Surface roughness: Ra 2.0-3.0 μm
(Note: the roughness in the upper 0.5mm part is Ra 0.5-0.6 μm)
- Uniform surface micro-pits of 1~3 μm
- Surface area increased by 46% compared to resorbable blast media (RBM) treated implants

In-vitro and In-vivo Bone Response

- Osteoblast differentiation and ossification improved by 20% compared to RBM-treated implants Initial bone response in a large animal model (mini-pig)
 - Initial stability (removal torque (RT), 4 weeks) improved by 48% compared to RBM-treated implants
 - Ossification (bone implant contact (BIC), 4 weeks) improved by 20% compared to RBM-treated implants

Low crystalline nano-HA coated SA surface

- Faster Bone Healing. Improved Osseointegration
- 10nm or less ultra-thin hydroxyapatite (HA) coating
- SA surface (Ra 2.0-3.0 μm) coated with HA
- Dual functions of titanium and HA
 - HA is naturally resorbed during ossification

In-vitro and In-vivo Bone Response

- Combination of advantages of both SA surfaces and HA
 - SA's ability to maintain the optimal surface morphology
 - HA's ability of high-quality bone formation even in bones of poor quality
- Ossification (BIC) improved by 40% compared to SA surfaces
- Applicable to all types of bone quality compared to HA

SSIII Implant System

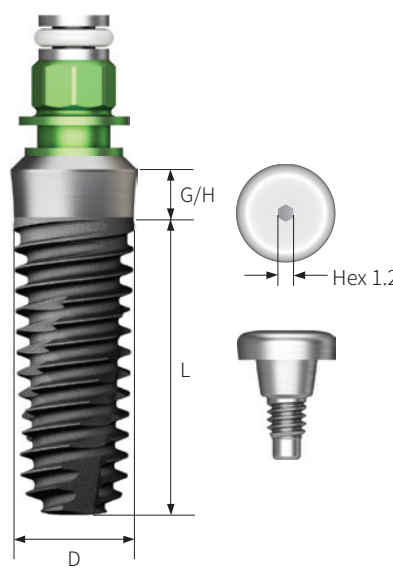
SS III Implant System	Guide
<p>Description</p> <ul style="list-style-type: none"> • Non-submerged type implant with an internal octa and 8° tapered connection • Optimized screw thread design with the ideal SA surface • Tapered body design with high initial stability • Corkscrew threading with excellent self-tapping effect • Excellent initial stability necessary for immediate loading, even in soft bone <p>Ultra-wide</p> <ul style="list-style-type: none"> • Ideal for posterior extracted tooth, for immediate placement, or for replacing a failed implant • Apex is specifically designed for excellent initial stability in an extracted tooth site • Recommended insertion torque: <= 40 Ncm • Implants with D4.5mm or more are recommended for the posterior area <div style="border: 1px solid #ccc; border-radius: 15px; padding: 10px; margin-top: 20px;"> <p>Order Code NoMount Implant: Code starts with "SS" Mount Implant: Code starts with "AS"</p> </div>	

Platform	Regular						Ultra-Wide	
G/H	1.8mm			2.8mm			2.0 mm	
P	Ø4.8			Ø4.8			Ø6.0	
D	Ø3.5	Ø4.0	Ø4.5	Ø3.5	Ø4.0	Ø4.5	Ø4.5	Ø5.0
<div style="display: flex; flex-direction: column; align-items: center;"> <div style="background-color: #008000; color: white; border-radius: 50%; width: 30px; height: 30px; display: flex; align-items: center; justify-content: center; margin-bottom: 5px;">R</div> <div style="background-color: #0070c0; color: white; border-radius: 50%; width: 30px; height: 30px; display: flex; align-items: center; justify-content: center; margin-bottom: 5px;">W</div> <div>L</div> </div>								
6mm	-	-	-	-	-	-	-	SS3W5006S20*
7mm	-	SS3R4007S18	SS3R4507S18	-	-	-	SS3W4507S20	SS3W5007S20
8.5mm	SS3R3508S18*	SS3R4008S18	SS3R4508S18	SS3R3508S28*	SS3R4008S28*	SS3R4508S28*	SS3W4508S20	SS3W5008S20
10mm	SS3R3510S18*	SS3R4010S18	SS3R4510S18	SS3R3510S28*	SS3R4010S28*	SS3R4510S28*	SS3W4510S20	SS3W5010S20
11.5mm	SS3R3511S18*	SS3R4011S18	SS3R4511S18	SS3R3511S28*	SS3R4011S28*	SS3R4511S28*	SS3W4511S20	SS3W5011S20
13 mm	SS3R3513S18*	SS3R4013S18	SS3R4513S18	SS3R3513S28*	SS3R4013S28*	SS3R4513S28*	SS3W4513S20	SS3W5013S20

※ Pre-Mount Only

Healing Abutment

Healing Abutment				
Description	Image/Guide			
<ul style="list-style-type: none"> Select appropriate mount according to the implant platform Tighten with a 1.2 hex hand driver P = Platform 				
H	2.0	3.0	4.0	5.0
R Regular W Wide				
Ø4.8	SSH482	SSH483	SSH484	SSH485
Ø6.0	-	SSH603	SSH604	-

Mount & Screw

Cover Screw			
Description	P	Regular	Wide
<ul style="list-style-type: none"> Select appropriate mount according to the implant platform Tighten with a 1.2 hex hand driver P = Platform 	R Regular W Wide		
		SSCS480	SSCS600





Closing Screw			
Description	P	Regular	Wide
<ul style="list-style-type: none"> Used when the soft tissue of the suture part is insufficient Tighten with a 1.2 hex hand driver P = Platform 	R Regular W Wide		
		SSCS480N	SSCS600N

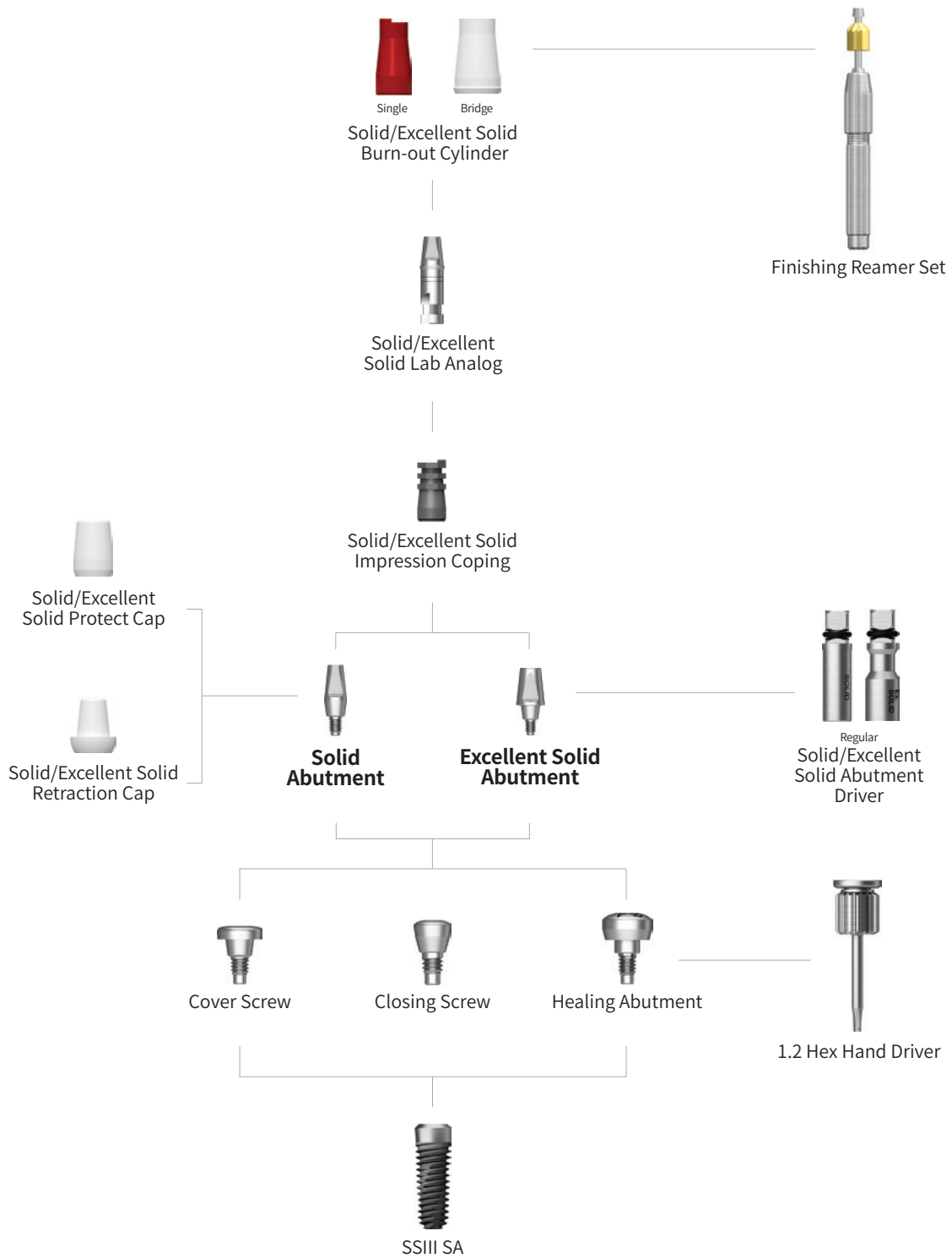

Solid/Excellent Solid

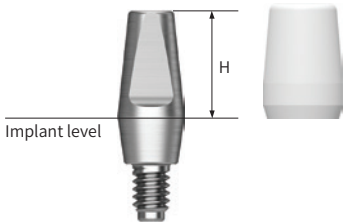

Abutment Level Impression





Solid Abutment





Solid Abutment				
Description	Image/Guide			
<ul style="list-style-type: none"> • Cement-retained prosthesis • Abutment level impression • Ø4.8: Torque using a solid abutment driver (code: SDSL/SDSS) • Ø6.0: Torque using a 1.2 hex driver or solid abutment driver • Recommended tightening torque: 30Ncm • Packing unit: abutment + protect cap 				
	H	4.0	5.5	7.0
	R Regular W Wide			
	Ø4.8 Ø6.0	SSS484P SSS604P	SSS485P SSS605P	SSS487P -



Solid Protect Cap				
Description	H	4.0	5.5	7.0
<ul style="list-style-type: none"> • Protects the solid abutment and minimizes patient irritation • Can be used as the base for a provisional crown 	R Regular W Wide			
	Ø4.8 Ø6.0	SSC484 SSC604	SSC485 SSC605	SSC487 -



Solid Impression Coping				
Description	H	4.0	5.5	7.0
<ul style="list-style-type: none"> • Components for solid abutment impression • Possibility of precise prosthesis using lab analog • Color coded by abutment height 	R Regular W Wide			
	Ø4.8 Ø6.0	SSIC484 SSIC604	SSIC485 SSIC605	SSIC487 -



Solid Lab Analog				
Description	H	4.0	5.5	7.0
<ul style="list-style-type: none"> • Components that replace resin caps before wax up using solid abutments • Used in the same color as solid impression coping 	R Regular W Wide			
	Ø4.8 Ø6.0	SSSA484 SSSA604	SSSA485 SSSA605	SSSA487 -

Solid Abutment Components

Solid Burn-out Cylinder			
Description	H	Single	Bridge
<ul style="list-style-type: none"> • Solid abutment components that reproduce them on the model after impression taking • Sophisticated prosthesis can be produced inside • After casting, remove the lower part of the margin holding part 	 Regular  Wide		
	Ø4.8 Ø6.0	SSSP480S SSSP600S	SSSP480B SSSP600B

Solid Impression Cap		
Description		Image/Item code
<ul style="list-style-type: none"> • An impression cap used when the solid abutment is trimmed • Used with a solid shoulder analog and analog pin 	 Regular  Wide	
	Ø4.8 Ø6.0	SSIP480 SSIP600

Solid Shoulder Analog		
Description		Image/Item code
<ul style="list-style-type: none"> • Impression product used when removing solid abutment • Reproducing the platform part of the implant in the work model • Used with solid impression cap and shoulder analog pin 	 Regular  Wide	
	Ø4.8 Ø6.0	SSSLA480 SSSLA600





Solid Shoulder Analog Pin		
Description		Image/Item code
<ul style="list-style-type: none"> • An impression coping component used when the solid abutment is trimmed • Reinforces the narrow part of the abutment • Used with a solid shoulder analog and impression cap 	 Regular  Wide	
	Ø4.8 Ø6.0	SSSAP480 SSSAP600





Excellent Solid Abutment





Excellent Solid Abutment				
Description	Image/Guide			
<ul style="list-style-type: none"> • Cement-retained prosthesis • Ideal for molar cases due to its larger volume (compared to the solid abutment), trim as needed • Abutment level impression • Ø4.8: Torque using a 1.2 hex driver or an excellent solid abutment driver (code: ESDSS/ESDSL) • Ø6.0: Torque using a 1.2 hex driver or an excellent solid abutment driver (code: ESD60S) • Recommended tightening torque: 30Ncm • Packing unit: abutment + protect cap 				
	H	4.0	5.5	7.0
	R Regular W Wide			
	Ø4.8 Ø6.0	SSE484P SSE604P	SSE485P SSE605P	SSE487P -



Excellent Solid Protect Cap				
Description	H	4.0	5.5	7.0
<ul style="list-style-type: none"> • Protects the solid abutment and minimizes patient irritation • Can be used as the base for a provisional crown 	R Regular W Wide			
	Ø4.8 Ø6.0	SSEC484 SSEC604	SSEC485 SSEC605	SSEC487 -

Excellent Solid Abutment Components

Excellent Solid Impression Coping				
Description	H	4.0	5.5	7.0
<ul style="list-style-type: none"> Impression components for Excellent solid abutment Possibility of precise prosthesis using lab analog Color coded by abutment height 	 Regular  Wide			
	Ø4.8 Ø6.0	SSEIC484 SSEIC604	SSEIC485 SSEIC605	SSEIC487 -

Excellent Solid Lab Analog				
Description	H	4.0	5.5	7.0
<ul style="list-style-type: none"> Components that replace resin caps before wax up using solid abutments Used in the same color as solid impression coping 	 Regular  Wide			
	Ø4.8 Ø6.0	SSEA484 SSEA604	SSEA485 SSEA605	SSEA487 -

Excellent Solid Burn-out Cylinder			
Description	HH	Single	Bridge
<ul style="list-style-type: none"> Excellent solid abutment components that reproduce this on the model after impression taking Sophisticated prosthesis can be produced inside After casting, remove the lower part of the margin holding part 	 Regular  Wide		
	Ø4.8 Ø6.0	SSEP480S SSEP600S	SSEP480B SSEP600B

Excellent Solid Impression Cap		
Description		Image/Item code
<ul style="list-style-type: none"> An impression cap used when the solid abutment is trimmed Used with a solid shoulder analog and analog pin 	 Regular  Wide	
	Ø4.8 Ø6.0	SSEIP480 SSEIP600

Solid Shoulder Analog		
Description		Image/Item code
<ul style="list-style-type: none"> • Impression product used when removing excellent solid abutment • Reproducing the platform part of the implant in the work model • Used with excellent solid impression cap and shoulder analog pin 	<p>R Regular</p> <p>W Wide</p>	
	<p>Ø4.8</p> <p>Ø6.0</p>	<p>SSSLA480</p> <p>SSSLA600</p>

Solid Shoulder Analog Pin		
Description		Image/Item code
<ul style="list-style-type: none"> • An impression coping component used when the solid abutment is trimmed • Reinforces the narrow part of the abutment • Used with a solid shoulder analog and impression cap 	<p>R Regular</p> <p>W Wide</p>	
	<p>Ø4.8</p> <p>Ø6.0</p>	<p>SSSAP480</p> <p>SSSAP600</p>

ComOcta/SmartFit

Abutment Level Impression

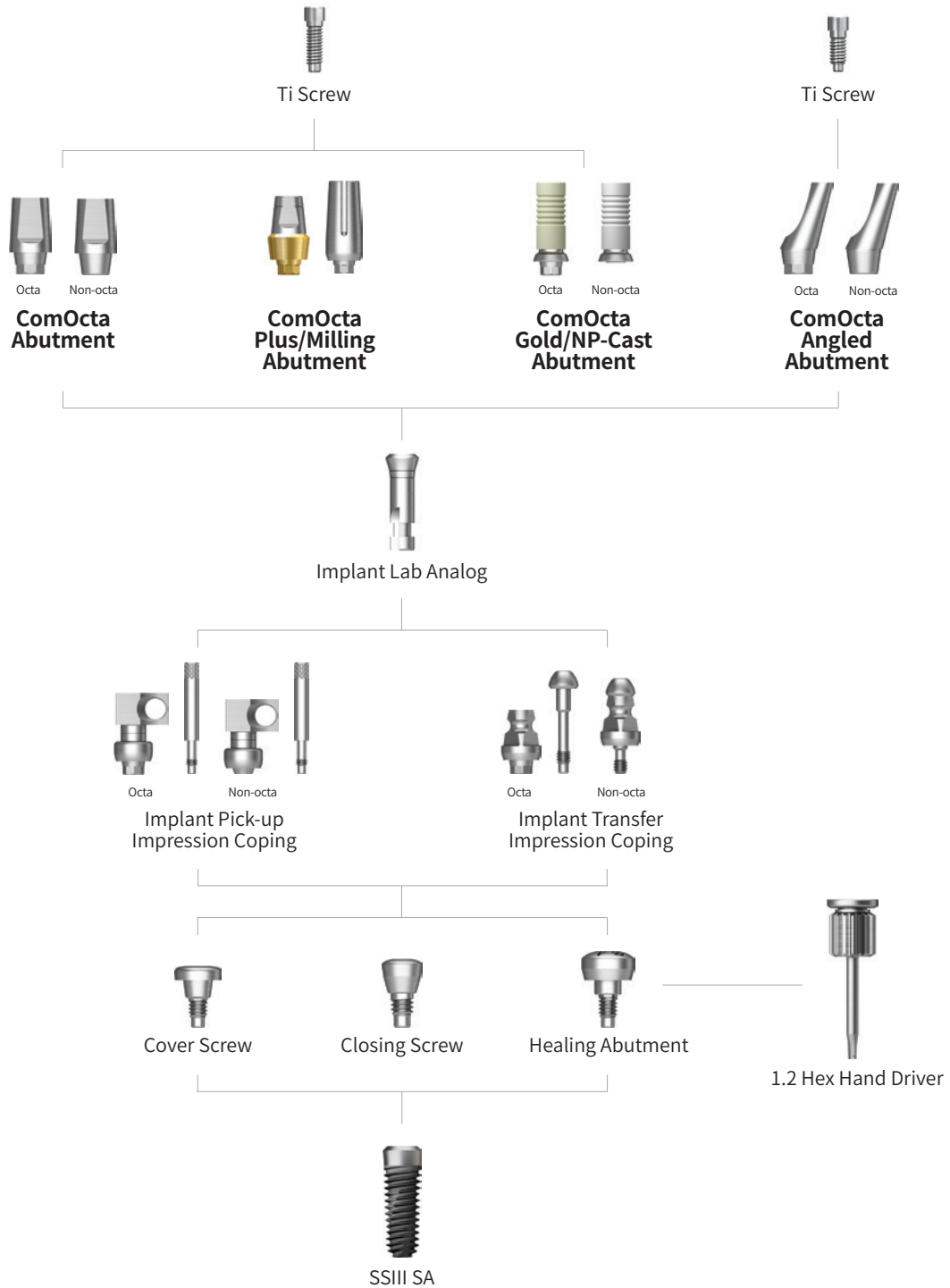



ComOcta Abutment



ComOcta Abutment						
Description			Image/Guide			
<ul style="list-style-type: none"> • Cement/combination-retained prosthesis • Implant level impression • Able to take abutment level impression using a retraction cap • Torque using a 1.2 hex driver • Recommended tightening torque: 30Ncm • Packing unit: abutment + Ti Screw 						
		Octa			Non-Octa	
H	4.0	5.5	7.0	4.0	5.5	7.0
R Regular W Wide						
Ø4.8	SSCA484TH	SSCA485TH	SSCA487TH	SSCA484NTH	SSCA484NTH	SSCA487NTH
Ø6.0	SSCA604TH	SSCA605TH	SSCA607TH	SSCA604NTH	SSCA605NTH	SSCA607NTH

ComOcta Plus Abutment

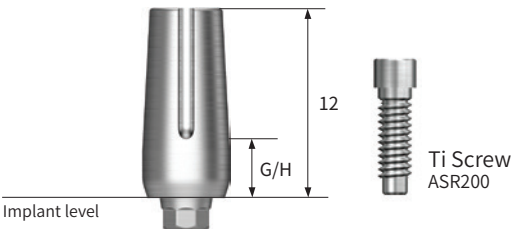

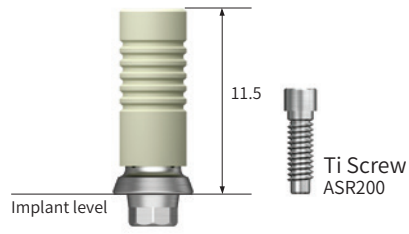

ComOcta Plus Abutment									
Description					Image/Guide				
<ul style="list-style-type: none"> • Cement/combination abutment for prosthesis manufacturing • Used when the gingiva is thick or the implant is deeply implanted • Abutment - implant interlock is 45° platform contact • Implant level impression • Torque using a 1.2 hex driver • Recommended torque of tightening screw: 30Ncm • Packing unit: abutment + Ti Screw 									
Octa									
H	4.0				5.5				
G/H	1.0	2.0	3.0	4.0	1.0	2.0	3.0	4.0	
<div style="display: flex; flex-direction: column; align-items: center;"> <div style="display: flex; align-items: center; gap: 5px;"> R Regular </div> <div style="display: flex; align-items: center; gap: 5px;"> W Wide </div> </div>									
Ø4.8	Ø5.5	SSCAP4814CTH	SSCAP4824CTH	SSCAP4834CTH	SSCAP4844CTH	SSCAP4816CTH	SSCAP4826CTH	SSCAP4836CTH	SSCAP4846CTH
	Ø6.0	-	-	-	-	-	SSCAP4826ETH	-	-
	Ø6.5	-	-	-	-	-	-	SSCAP4836ETH	-
	Ø7.0	-	-	-	-	-	-	-	SSCAP4846ETH
Ø6.0	Ø6.5	SSCAP6014CTH	SSCAP6024CTH	SSCAP6034CTH	SSCAP6044CTH	SSCAP6016CTH	SSCAP6026CTH	SSCAP6036CTH	SSCAP6046CTH
	Ø6.8	-	-	-	-	-	SSCAP6026ETH	-	-
	Ø7.2	-	-	-	-	-	-	SSCAP6036ETH	-
	Ø7.6	-	-	-	-	-	-	-	SSCAP6046ETH
Non-Octa									
H	4.0				5.5				
G/H	1.0	2.0	3.0	4.0	1.0	2.0	3.0	4.0	
<div style="display: flex; flex-direction: column; align-items: center;"> <div style="display: flex; align-items: center; gap: 5px;"> R Regular </div> <div style="display: flex; align-items: center; gap: 5px;"> W Wide </div> </div>									
Ø4.8	Ø5.5	-	-	-	-	SSCAP4816CNTH	SSCAP4826CNTH	SSCAP4836CNTH	SSCAP4846CNTH
	Ø6.0	-	-	-	-	-	SSCAP4826ENTH	-	-
	Ø6.5	-	-	-	-	-	-	SSCAP4836ENTH	-
	Ø7.0	-	-	-	-	-	-	-	SSCAP4846ENTH
Ø6.0	Ø6.5	-	-	-	-	SSCAP6016CNTH	SSCAP6026CNTH	SSCAP6036CNTH	SSCAP6046CNTH
	Ø6.8	-	-	-	-	-	SSCAP6026ENTH	-	-
	Ø7.2	-	-	-	-	-	-	SSCAP6036ENTH	-
	Ø7.6	-	-	-	-	-	-	-	SSCAP6046ENTH



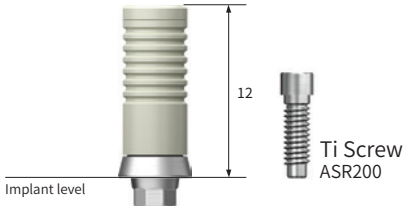

ComOcta Abutment Components





ComOcta Milling Abutment			
Description	Type	Octa	Non-Octa
<ul style="list-style-type: none"> Cement/combination/screw-retained prosthesis Customized prosthesis cast with gold alloy Abutment fastens to the platform at a 45° angle Abutment melting point: 1400-1450°C (2552~2642°F) Implant level impression Torque using a 1.2 hex driver Recommended tightening torque: 30Ncm Packing unit: abutment + Ti Screw 	<p>R Regular</p> <p>W Wide</p>		
	<p>Ø4.8</p> <p>Ø6.0</p>	SSCMA4830TH	SSCMA6030TH

ComOcta Gold Abutment			
Description	Type	Octa	Non-Octa
<ul style="list-style-type: none"> Cement/combination/screw-retained prosthesis Customized prosthesis cast with gold alloy Abutment fastens to the platform at a 45° angle Abutment melting point: 1400-1450°C (2552~2642°F) Implant level impression Torque using a 1.2 hex driver Recommended tightening torque: 30Ncm Packing unit: abutment + Ti Screw 	<p>R Regular</p> <p>W Wide</p>		
	<p>Ø4.8</p> <p>Ø6.0</p>	<p>COG480STH</p> <p>COG600STH</p>	<p>COG480BTH</p> <p>COG600BTH</p>



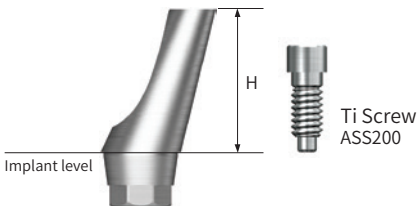



ComOcta Abutment Components



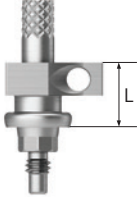

ComOcta NP-Cast Abutment			
Description	Type	Octa	Non-Octa
<ul style="list-style-type: none"> Cement/combination/screw-retained prosthesis Customized prosthesis cast with non-precious alloy Abutment fastens to the platform at a 45° angle Abutment melting point: 1400-1450°C (2552~2642°F) Implant level impression Torque using a 1.2 hex driver Recommended tightening torque: 30Ncm Packing unit: abutment + Ti Screw 	 Regular  Wide		

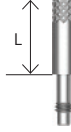

ComOcta Protect Cap				
Description	H	4.0	5.5	7.0
<ul style="list-style-type: none"> Protects ComOcta abutment final prosthesis Can be used as a temporary crown base Excellent Solid Protect Cap can substitute for wide type 	 Regular  Wide			

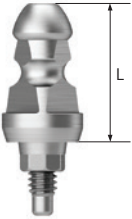
ComOcta Angled Abutment			
Description	Type	Octa	
	Angle	15°	20°
<ul style="list-style-type: none"> Cement/combination-retained prosthesis Angle compensation between 15°/20° Use dedicated abutment screw Implant level impression Torque using a 1.2 hex driver Recommended tightening torque: 30Ncm Packing unit: abutment + Ti screw (only angled) <p>Abutment + Ti Screw order code :product code + TH (ex: SSA4815TH)</p> 	 Regular  Wide		

ComOcta Abutment Components

Implant Pick-up Impression Coping					
Description				Image/Guide	
<ul style="list-style-type: none"> • Components for implant level impression taking • For open tray impressions • Unique design that is fixed position in the impression material • Connect with a 1.2 hex hand driver • Packing unit: impression coping body + guide pin(*) 					
Type	Octa	Non-Octa	Guide Pin		
L	10		10	15	17
 Regular  Wide					
Ø4.8 Ø6.0	SSICA480 SSICA600	SSICA480N -	CSR100*(L5)	CSR150*(L10)	CSR170

Implant Transfer Impression Coping			
Description	Type	Octa	
	L	9.5	12.5
<ul style="list-style-type: none"> • Components for implant level impression taking • For closed tray impressions • Triangular arc enabling precise placement • Tighten with a 1.2 hex hand driver • Packing unit <ul style="list-style-type: none"> - Octa: impression coping body + guide pin - Non-octa: impression coping 	 Regular  Wide		
	Ø4.8 Ø6.0	SSCTIS480TH SSCTIS600TH	SSCTIL480TH SSCTIL600TH



Implant Lab Analog		
Description		Image/Item code
<ul style="list-style-type: none"> • A lab analog for implant level impression • Select an appropriate implant platform; Ø4.8/6.0 	 Regular  Wide	
	Ø4.8 Ø6.0	SSFA480 SSFA600

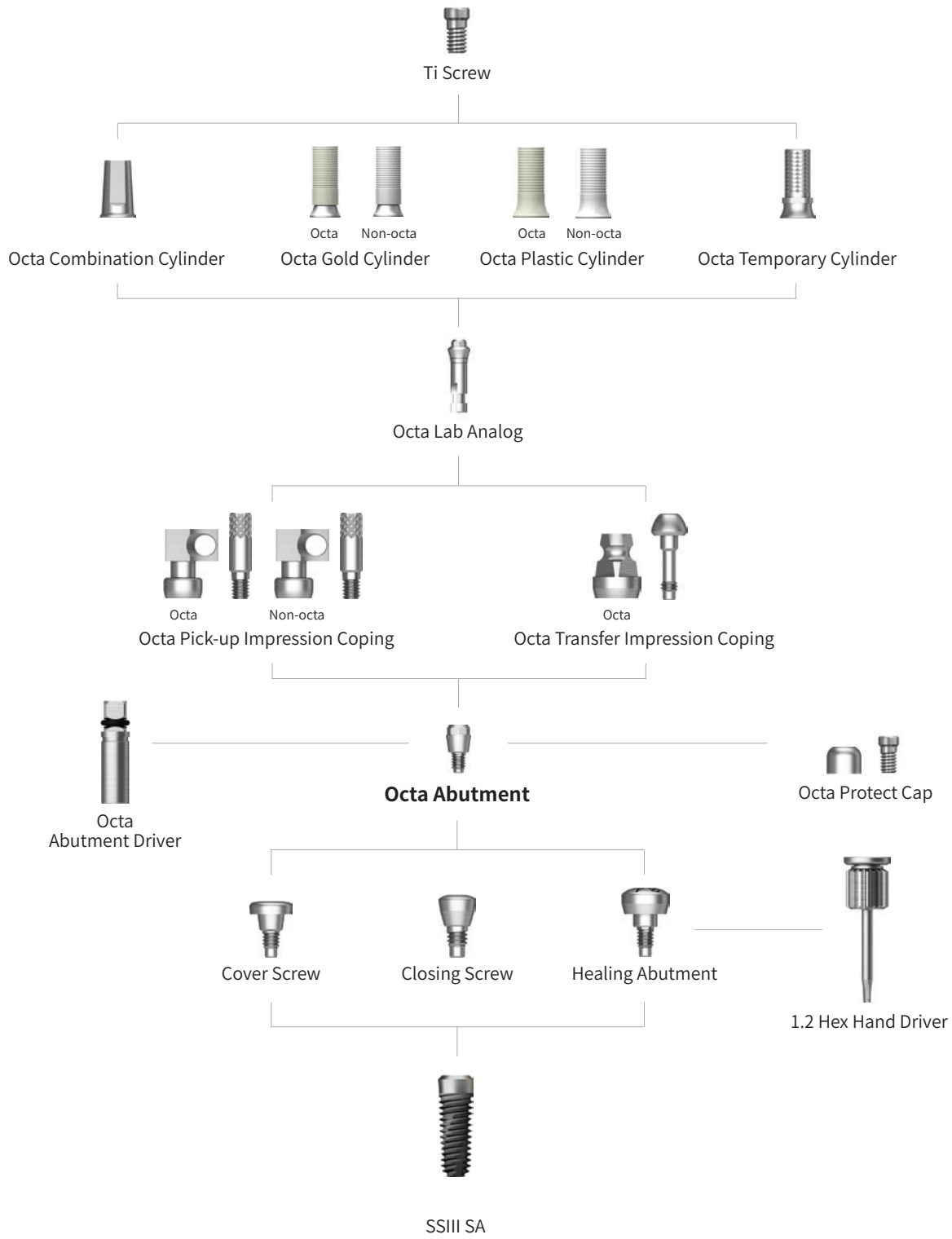

Octa



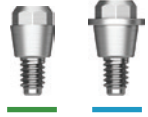

Abutment Level Impression







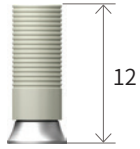
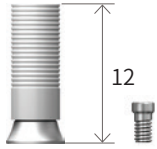

Octa Abutment

Octa Abutment		
Description		Image/Item code
<ul style="list-style-type: none"> Screw-retained prosthesis for multiple prosthetic options Angle compensation of up to 60° Torque using a dedicated outer driver (code: ODSL/ODSS) Recommended tightening torque: 30Ncm 	 Regular  Wide	
	Ø4.8 Ø6.0	SSOA480 SSOA600





Octa Protect Cap		
Description		Image/Item code
<ul style="list-style-type: none"> Protective cap Tighten with a 1.2 hex hand driver Packing unit: protect cap + Ti Screw 	 Regular  Wide	 Ti Screw: SSFS (Ø4.8 Ø6.0)
	Ø4.8 Ø6.0	SSHC480TH SSHC600TH

Octa Gold Cylinder			
Description	Type	Octa	Non-Octa
<ul style="list-style-type: none"> Screw-retained prosthesis Customized prosthesis cast with gold alloy Cylinder melting point: 1400-1450°C (2552~2642°F) Torque using a 1.2 hex driver Recommended tightening torque: 20Ncm Packing unit: cylinder + Ti cylinder screw 	 Regular  Wide		
	 Ti Screw: SSFS (Ø4.8 Ø6.0)	Ø4.8 Ø6.0	SSGCO480TH SSGCO600TH

Octa Temporary Cylinder		
Description	G/H	0
<ul style="list-style-type: none"> Provisional prosthesis (Ti Gr-3) Torque using a 1.2 hex driver Recommended tightening torque: 20Ncm Packing unit: cylinder + Ti cylinder screw 	 Regular  Wide	 Ti Screw: SSFS (Ø4.8 Ø6.0)
	Ø4.8 Ø6.0	SSTCO480TH SSTCO600TH

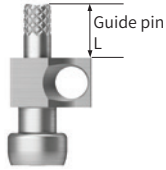
Octa Plastic Cylinder		
Description	G/H	0
<ul style="list-style-type: none"> Screw-retained prosthesis Customized prosthesis cast with non-precious alloys Torque using a 1.2 hex driver Recommended tightening torque: 20Ncm Packing unit: cylinder + Ti cylinder screw 	 Regular  Wide	 Ti Screw: SSFS (Ø4.8 Ø6.0)
	Ø4.8 Ø6.0	SSPSO480TH SSPSO600TH

Octa Abutment Components

Octa Pick-up Impression Coping				
Description	Type	Octa	Guide Pin	
	L		0	5.0
<ul style="list-style-type: none"> A pick up impression coping for octa abutment Tighten with a 1.2 hex hand driver Packing unit: impression coping body + guide pin(*) 	<p>R Regular</p> <p>W Wide</p>			
	<p>Ø4.8</p> <p>Ø6.0</p>	<p>SSICO480</p> <p>SSICO600</p>	<p>SSGS100</p>	<p>SSGS150*</p>

Octa Transfer Impression Coping		
Description		Image/Item code
<ul style="list-style-type: none"> Hand tightened with a 1.2 hex driver Packing unit: Impression coping body + Guide pin 	<p>R Regular</p> <p>W Wide</p>	
	<p>Ø4.8</p> <p>Ø6.0</p>	<p>SSOTI480</p> <p>SSOTI600</p>

Octa Lab Analog		
Description		Image/Item code
<ul style="list-style-type: none"> Lab analog Tighten with a 1.2 hex hand driver 	<p>R Regular</p> <p>W Wide</p>	
	<p>Ø4.8</p> <p>Ø6.0</p>	<p>SSLA480</p> <p>SSLA600</p>



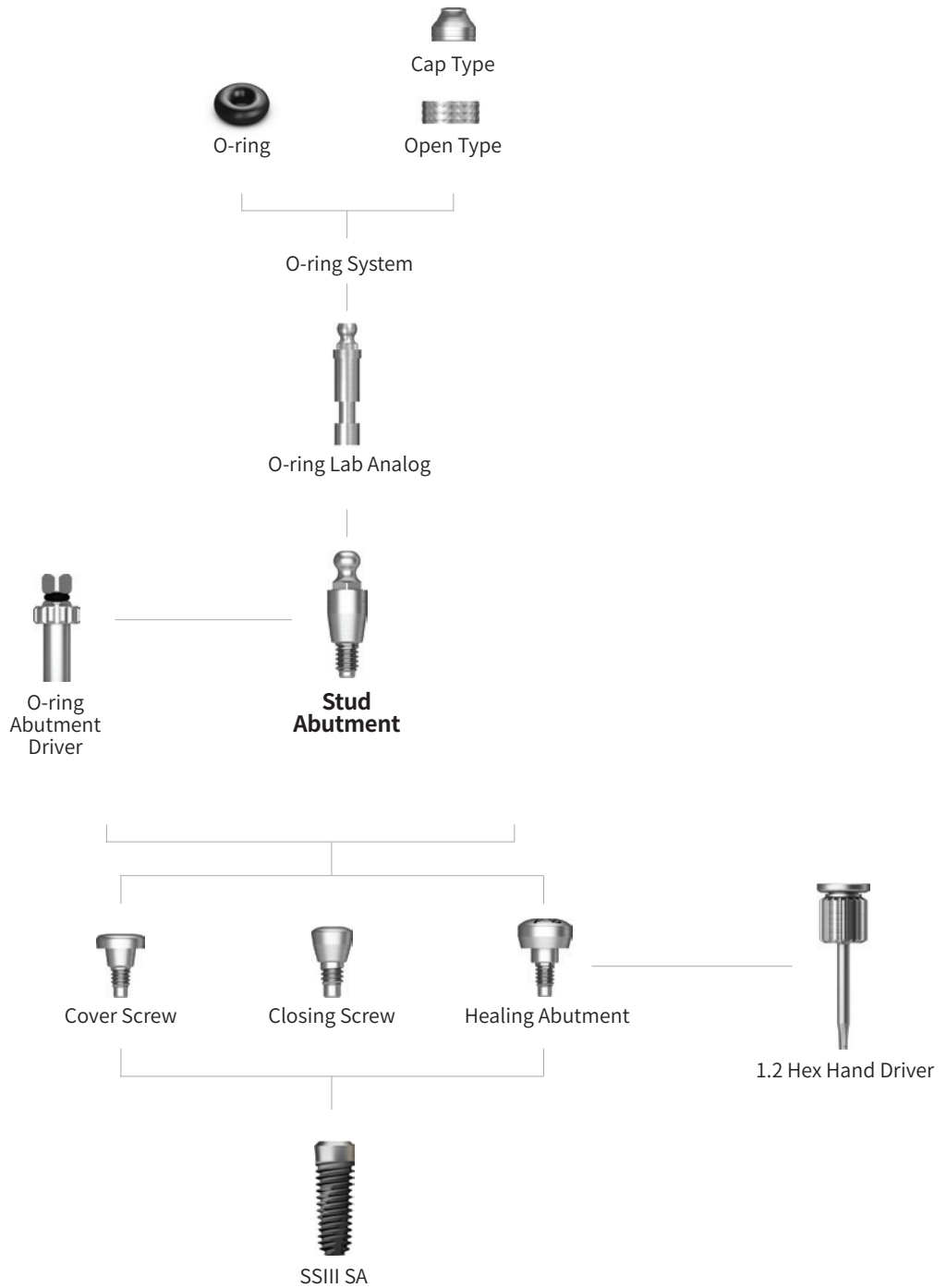

HIOSSEN
IMPLANT

O-ring

Overdenture

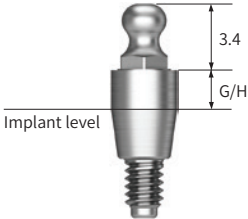



O-ring Abutment

O-ring Abutment					
Description	G/H	0	2.0	4.0	
<ul style="list-style-type: none"> Retains overdenture with o-ring system Angle compensation of up to 20° Torque using an outer driver (code: AORD) Recommended tightening torque: 30Ncm 					
		Ø4.8	SSRA000	SSRA200	SSRA400
		Ø6.0	SSWA000	SSWA200	SSWA400

O-ring Retainer Cap Set	
Description	Image/Item code
<ul style="list-style-type: none"> O-ring housing Place an appropriate o-ring in the metal housing before connecting to the abutment Packing unit: retainer cap + O-ring 	
	RCS01

O-ring Set	
Description	Image/Item code
<ul style="list-style-type: none"> O-ring set Packing unit: O-ring x 5ea 	
	OAON01S

O-ring Retainer Set	
Description	
<ul style="list-style-type: none"> Used when vertical dimension is shorter than the retainer cap Packing unit: retainer cap + O-ring 	
Retainer	O-ring
	
RS01	

O-ring Lab Analog (Denture)	
Description	Image/Item code
<ul style="list-style-type: none"> A lab analog for O-ring abutment 	
	MSDLA

HIOSSEN
IMPLANT

EM

IMPLANT SYSTEM

Narrow Ridge	112
Denture	113
Provisional	114

EM Implant System Narrow Ridge

Narrow Ridge					Image/Guide
Description					
<ul style="list-style-type: none"> Implants suitable for narrow spaces such as mandibular anterior teeth Applied SA surface with excellent osseointegration performance Optimized abutment shape and size without prosthesis removal Recommended insertion torque: 30Ncm or less 					
G/H	2.5mm		4.0mm		
D	Ø2.5	Ø3.0	Ø2.5	Ø3.0	
L					
8.5 mm	EMN2508S25	EMN3008S25	EMN2508S40	EMN3008S40	
10 mm	EMN2510S25	EMN3010S25	EMN2510S40	EMN3010S40	
11.5 mm	EMN2511S25	EMN3011S25	EMN2511S40	EMN3011S40	
13 mm	EMN2513S25	EMN3013S25	EMN2513S40	EMN3013S40	
15 mm	EMN2515S25	EMN3015S25	EMN2515S40	EMN3015S40	

Components

Impression Coping (Narrow Ridge)	
Description	Image/Item code
<ul style="list-style-type: none"> Used for taking precise impression 	
	MSPIC

Temporary Cap	
Description	Image/Item code
<ul style="list-style-type: none"> Used for temporary prosthesis production 	
	MSPTC

Lab Analog	
Description	Image/Item code
<ul style="list-style-type: none"> Lab Analog for EM Implant Narrow Ridge 	
	MSPLA

Burn-out Cylinder		
Description	Single	Bridge
<ul style="list-style-type: none"> Used as a prosthetic framework by attaching onto EM Implant Narrow Ridge After prosthetic casting, the margin is adjusted with a dedicated reamer 		
	MSPBCS	MSPBCB

EM Implant System Denture

Denture							Image/Guide
Description							
<ul style="list-style-type: none"> Implants used for edentulous patients with narrow bone widths Applied SA surface with excellent osseointegration performance Easier and more convenient for denture cases Recommended insertion torque: 30Ncm or less 							
G/H	2.0mm			4.0mm			
D	Ø2.0	Ø2.5	Ø3.0	Ø2.0	Ø2.5	Ø3.0	
L							
8.5 mm	EMD2008S20	EMD2508S20	EMD3008S20	EMD2008S40	EMD2508S40	EMD3008S40	
10 mm	EMD2010S20	EMD2510S20	EMD3010S20	EMD2010S40	EMD2510S40	EMD3010S40	
11.5 mm	EMD2011S20	EMD2511S20	EMD3011S20	EMD2011S40	EMD2511S40	EMD3011S40	
13 mm	EMD2013S20	EMD2513S20	EMD3013S20	EMD2013S40	EMD2513S40	EMD3013S40	
15 mm	EMD2015S20	EMD2515S20	EMD3015S20	EMD2015S40	EMD2515S40	EMD3015S40	

Components

O-ring Retainer Cap Set	
Description	Image/Item code
<ul style="list-style-type: none"> O-ring housing Place an appropriate O-ring in the metal housing before connecting to the abutment Packing unit: Retainer cap + O-ring 	
	RCS01

O-ring Set	
Description	Image/Item code
<ul style="list-style-type: none"> O-ring set Packing unit: O-ring x 5ea 	
	OAON01S

O-ring Retainer Set	
Description	Image/Item code
<ul style="list-style-type: none"> O-ring housing Used when vertical height is shorter than the retainer cap Packing unit: Retainer + O-ring 	
	OARS01

O-ring Lab Analog (Denture)	
Description	Image/Item code
<ul style="list-style-type: none"> Lab analog for stud abutment 	
	MSDLA

EM Implant System Provisional

Provisional			Image/Guide
Description			
<ul style="list-style-type: none"> Used for temporary prosthesis placement for full or partially edentulous patients Neck design to compensate path while maintaining strength Utilize provisional cap and lab analog to make temporary prosthesis One-time neck adjustment up to 30° Recommended insertion torque: 30Ncm or less 			
D	Ø1.8	Ø2.5	
L			
10 mm	EMT18104	EMT25104	
13 mm	EMT18134	EMT25134	
15 mm	EMT18154	EMT25154	

Components

Provisional Cap	
Description	Image/Item code
<ul style="list-style-type: none"> Used for temporary prosthesis production (titanium) 	
	MSTPC

Lab Analog	
Description	Image/Item code
<ul style="list-style-type: none"> Used for temporary prosthesis placement for full or partially edentulous patients Neck design to compensate path while maintaining strength Utilize provisional cap and lab analog to make temporary prosthesis One-time neck adjustment up to 30° Recommended insertion torque: 30Ncm or less 	
	MSTLA









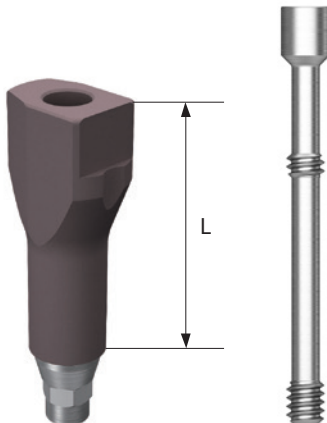

HIOSSEN
IMPLANT

HiOSSEN
IMPLANT

DIGITAL PROSTHETICS

Scan body	118
Scan Healing Abutment	119
Digital Lab Analog	120
Link Abutment for CEREC™	122
ET / EK Pre-Milled Abutment	123

Digital Prosthetics Scan Body

Scan Body			
Description	Implant System	Short(8mm)	Long(12mm)
<ul style="list-style-type: none"> A digital impression coping for EK or ET Implant system Tighten with a 1.2 hex hand driver Packing unit: scan body + Ti Screw 	EK System 		
		EKNSBSTH	EKNSBLTH
	ET System  <p>Mini Screw Coloring : Yellow</p>		
		ETNSBMSTH	ETNSBMLTH
	ET System  <p>Regular Screw Coloring : Green</p>		
		ETNSBRSTH	ETNSBRLTH





ET Multi Scan Body	
Description	Image/Item code
<ul style="list-style-type: none"> Used by attaching to ET Multi Abutment for intra oral scanning Non-Hex type Torque using 1.2 Hex Driver 	
	TMSBC

Digital Prosthetics Scan Healing Abutment

Scan Healing Abutment				
Description		Image/Guide		
<ul style="list-style-type: none"> • Healing Abutment with scan body function • Specifications are identified by the number and sizes of the indents on the abutment head • Abutment level impression • Dedicated abutment screws for each length (cannot be mixed) • Torque using Scan Healing Abutment Carrier or 1.2 Hex Driver • Packing unit: Scan Healing Abutment + Abutment Screw 				
H	4.0	5.0	7.0	9.0
	1 marking	2 markings	3 markings	4 markings
M Mini				
Ø4.0	TSSHA404MTH	TSSHA405MTH	TSSHA407MTH	TSSHA409MTH
R Regular				
Ø4.5	TSSHA454RTH	TSSHA455RTH	TSSHA457RTH	TSSHA459RTH
Ø5.0	TSSHA504RTH	TSSHA505RTH	TSSHA507RTH	TSSHA509RTH
Ø6.0	TSSHA604RTH	TSSHA605RTH	TSSHA607RTH	TSSHA609RTH

Scan Healing Abutment Carrier				
Description		Image/Guide		
<ul style="list-style-type: none"> • Able to connect to Scan Healing Abutment and tighten • Size dependent on Scan Healing Abutment size • Material: PEEK + TrimRite 				
D	4.0	4.5	5.0	6.0
M Mini				
R Regular				
Short	TSSHAC400	TSSHAC450	TSSHAC500	TSSHAC600
Long	TSSHAC400L	TSSHAC450L	TSSHAC500L	TSSHAC600L

Digital Prosthetics Digital Lab Analog



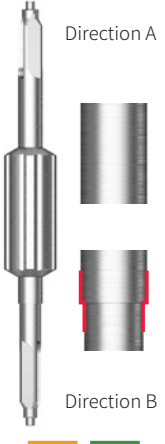

Digital Lab Analog				
Description	EK System	D Ø3.3 / 3.5	D Ø4.0 & Above	
<ul style="list-style-type: none"> An lab analog for creating digital implant working models (e.g., 3D-Printed Model) Tighten with a 1.2 hex hand driver Convenient specification differentiation via color coding of the lab analog Easy and precise connection/seating using dedicated lab analog tools, such as the Reamer Drill and Positioning Jig Packing unit: Digital lab analog + Fixing screw 				
		EKDLA350	EKDLA400	
	ET System	Mini	Regular	
	 Mini  Regular			
	Ø3.2 Ø3.5 Regular	TSDLA300 TSDLA350 -	- - TSDLA400	
	EK & ET System	Multi Abutment		
				
	TSDLA			





Digital Prosthetics

Reamer Drill												
Description		Image/Item code										
<ul style="list-style-type: none"> Used to clear the holes of the 3D-Printed Model where the Analog will be inserted <p>DLARDM300</p> <hr/> <p>Type</p> <p>ET Ø3.0</p> <p>DLARDR</p> <hr/> <table border="1"> <thead> <tr> <th>Type</th> <th>Direction A</th> <th>Direction B</th> </tr> </thead> <tbody> <tr> <td>EK</td> <td>Ø4.0</td> <td>Ø3.5</td> </tr> <tr> <td>ET</td> <td>Regular / Multi</td> <td>Mini</td> </tr> </tbody> </table>	Type	Direction A	Direction B	EK	Ø4.0	Ø3.5	ET	Regular / Multi	Mini	<div style="display: flex; flex-direction: column; align-items: center;"> <div style="display: flex; align-items: center; margin-bottom: 5px;"> <div style="background-color: orange; color: white; border-radius: 50%; width: 20px; height: 20px; display: flex; align-items: center; justify-content: center; margin-right: 5px;">M</div> Mini </div> <div style="display: flex; align-items: center;"> <div style="background-color: green; color: white; border-radius: 50%; width: 20px; height: 20px; display: flex; align-items: center; justify-content: center; margin-right: 5px;">R</div> Regular </div> </div>		
	Type	Direction A	Direction B									
EK	Ø4.0	Ø3.5										
ET	Regular / Multi	Mini										
		DLARDM300	DLARDR									

Positioning Jig			
Description	EK System	ET System	Multi Abutment
<ul style="list-style-type: none"> Used to connect Digital Lab Analogs to the 3D-Printed Models' holes 			
	KSDLAPJ	GSDLAPJ	TSMDLAPJ



Digital Prosthetics Link Abutment for CEREC™



Link Abutment			
Description	Type	Hex	Non-Hex
<ul style="list-style-type: none"> Cement-retained/screw-retained/combination type prosthesis CEREC™ CAD/CAM manufactured custom abutment with titanium base and milled zirconia Torque using a 1.2 hex driver Recommended tightening torque :20Ncm(mini), 30Ncm(regular) Library NB B 3.4 	 Mini  Regular		
	Mini Regular	HGCTBMHW HGCTBRHW	HGCTBMNW HGCTBRNW

Scan Post			
Description	Type	Mini	Regular
<ul style="list-style-type: none"> Special post to scan the position of the implant where space is limited (e.g. thick soft tissue, deeply inserted implant) Use with Scan Body (e.g. Connect Scan Body before scanning) Tighten with a 1.2 hex hand driver Packing unit: scan post + Ti Screw Library NB B 3.4 	 Mini  Regular		
		HGCSMHL	HGCSRHL

Scan Body	
Description	Image/Item code
<ul style="list-style-type: none"> Scan after connecting to a link abutment for CEREC™, or a scan post Packing unit: scan body x 10ea. 	
	HGCSBG

Digital Prosthetics Pre-Milled Abutment

EK Pre-Milled Abutment				
Description			Image/Guide	
<ul style="list-style-type: none"> To create a custom abutment using a milling machine Genuine Hiossen mark for easy authenticity check Higher fitting precision than non-genuine parts Compatible with multiple milling brands Recommended torque: 30 Ncm Packing unit : abutment + Ti screw <div style="display: flex; justify-content: space-around; align-items: center;"> <div style="text-align: center;">  <p>EK Hex Abutments have Abutment Holding System at the bottom</p> </div> <div style="text-align: center;">  <p>EK Non-Hex abutments have three indents at the bottom</p> </div> </div>			 <p>D</p>	
D	10.0		14.0	
Type	Hex	Non-Hex	Hex	Non-Hex
EK Platform	EKPMA10ARHT	EKPMA10ARNT	EKPMA14ARHT	EKPMA14ARHT

ET Pre-Milled Abutment				
Description			Image/Guide	
<ul style="list-style-type: none"> To create a custom abutment using a milling machine Genuine Hiossen mark for easy authenticity check Higher fitting precision than non-genuine parts Compatible with multiple milling brands Packing unit : abutment + EbonyGold screw or Ti screw <div style="display: flex; margin-top: 20px;"> <div style="margin-right: 10px;">  Mini </div> <div>  Regular </div> </div>			 <p>D</p>	
D	10.0		14.0	
Type	Hex	Non-Hex	Hex	Non-Hex
Mini	ETPMA10ARMHW	ETPMA10ARMNW	ETPMA14ARMHW	ETPMA14ARMNW
Regular	ETPMA10ARRHW	ETPMA10ARRNW	ETPMA14ARRHW	ETPMA14ARRNW

HIOSSEN
IMPLANT

SURGICAL KIT

GUIDED SURGERY KIT

ET OneGuide Kit	126
EK OneGuide Kit	127
OneCAS Kit	138
OneEM Kit	144
One485 Kit	150

IMPLANT SURGERY KIT

122 Taper Kit	154
Taper Kit	162
Taper Ultra Kit	163
485 Kit	174
Assist Kit	178
Ultra Kit	182

PROSTHETIC & MAINTENANCE KIT

Prosthetic Simple	190
Prosthetic Kit	191
ESR Kit	198
ESR Full Kit	199
EIR Kit	204
EIR Full Kit	205
IM-Cure Kit	208

SINUS SURGERY KIT

CAS Kit	212
LAS Kit	216

NARROW RIDGE SURGERY KIT

ESSET Kit	218
EM Kit	222

SURGICAL INSTRUMENT

Surgical Instruments Kit	226
--------------------------	-----

ET OneGuide Kit (HOGK)

For

ETIII/IV

SSII/III

Top panel components

Torque Wrench
TQWCB



Depth Gauge
ODG

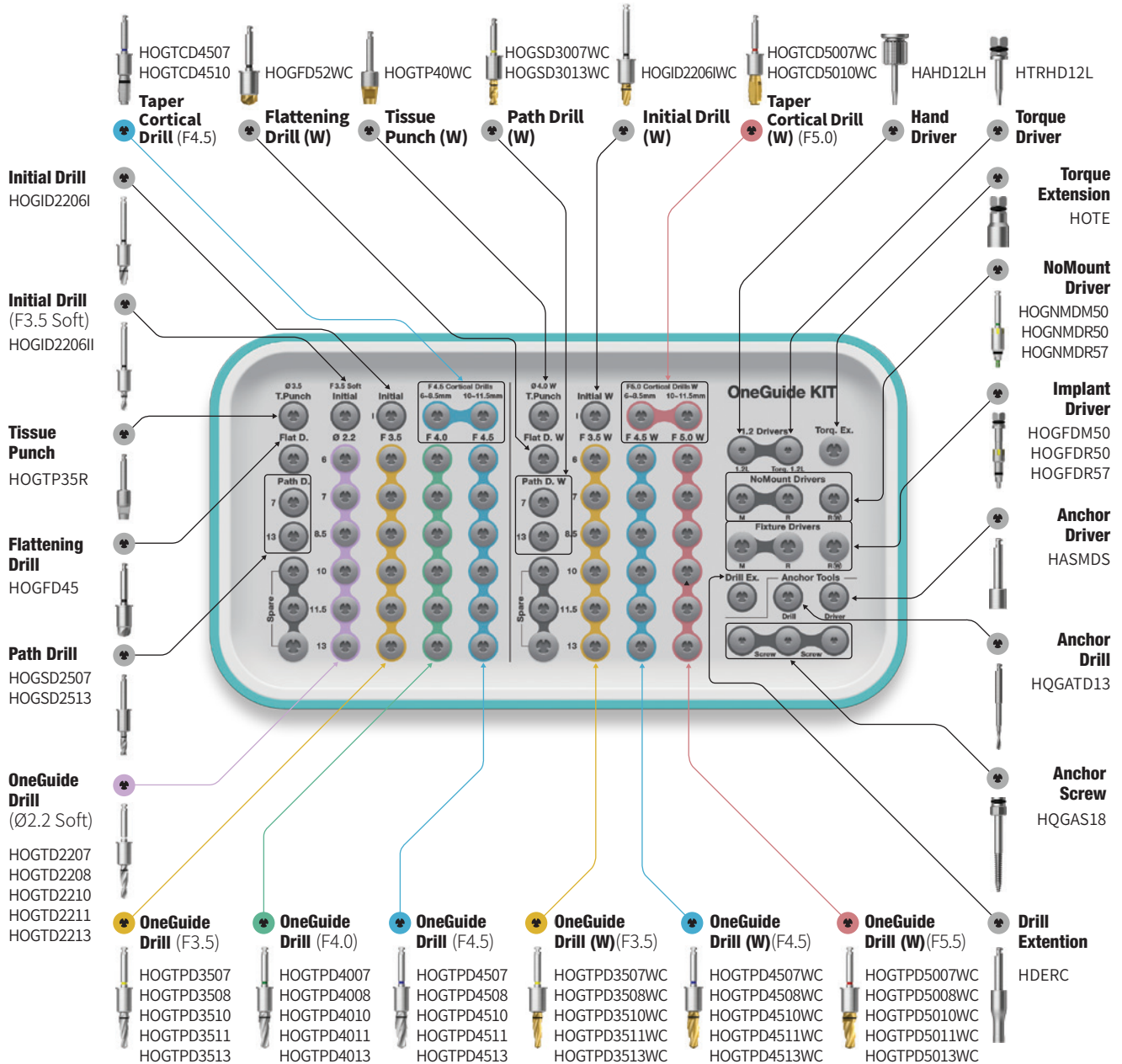

EK OneGuide Kit (HKOGK)

For

EKIII

SSII/III

Top panel components

Torque Wrench

TQWCB



Depth Gauge

ODG

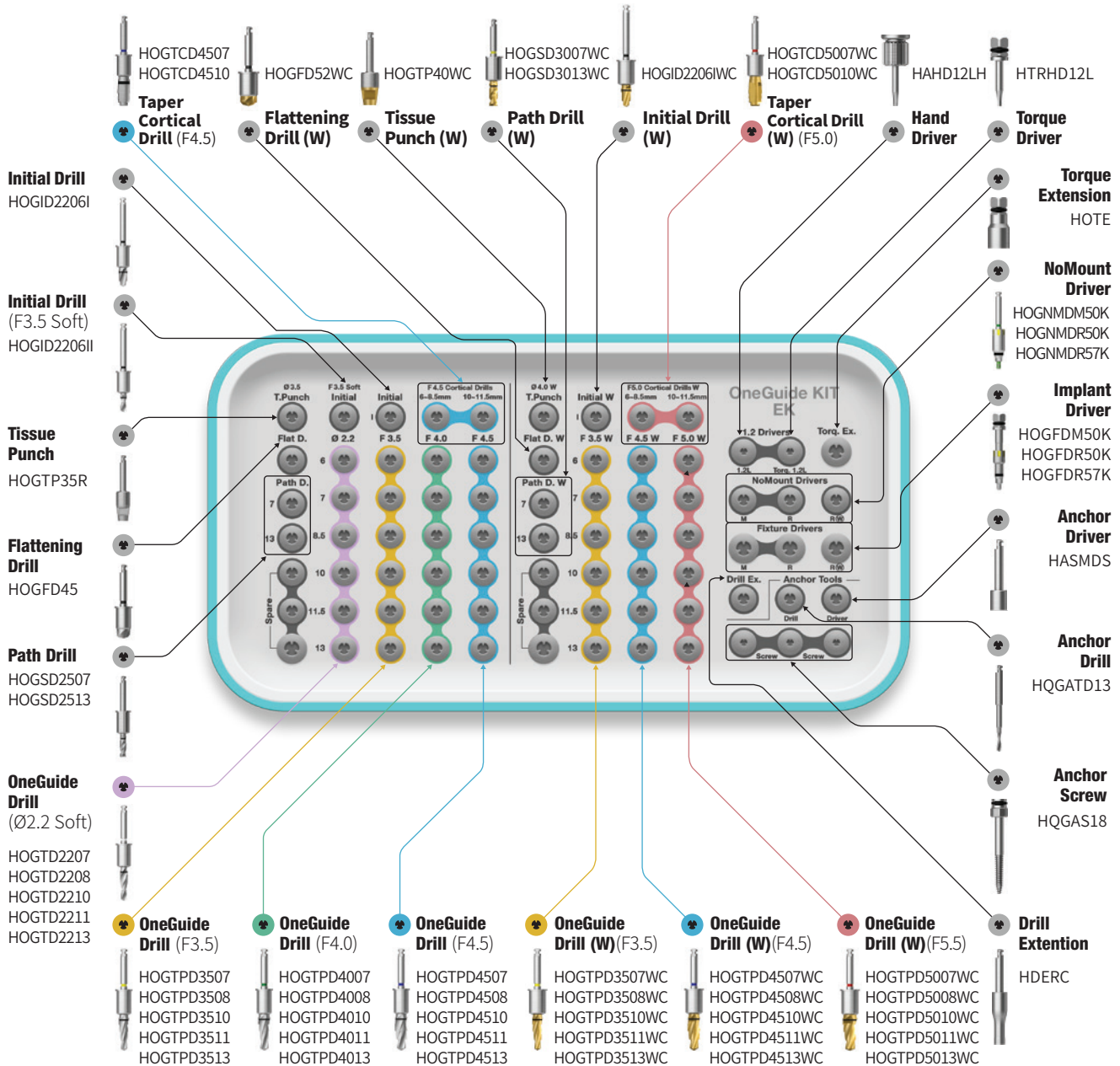

OneGuide Kit Surgical Kit Instruments

OneGuide Template	
Description	Image
<ul style="list-style-type: none"> Two sizes of guide holes depending on the diameter of the implant <ul style="list-style-type: none"> - D5.0 for implant diameters: F3.5/4.0/4.5 - D5.8 for implant diameter: F5.0 Dual contact feature ensures excellent accuracy in positioning and stability Simple drilling sequence by adopting 122 Taper Kit concepts Packing unit: surgical guide (optional: SmartFit abutment, Temporary Crown) 	

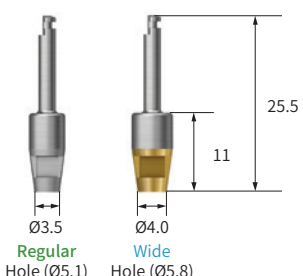
Tissue Punch				
Description	D/Ø	Regular Hole (Ø5.1)	Wide Hole (Ø5.8)	Image/Guide
<ul style="list-style-type: none"> Used to remove gingiva flaplessly 7 types according to the OneGuide guide holes Drills except two types are not included in the Kit (HOGTP35R, HOGTP40WC) and are sold separately Recommended speed: 800 ~ 1,200 rpm 	Ø3.0	HOGTP30R	-	
	Ø3.5	HOGTP35R	-	
	Ø4.0	HOGTP40R	HOGTP40WC	
	Ø4.5	HOGTP45R	HOGTP45WC	
	Ø5.0	-	HOGTP50WC	

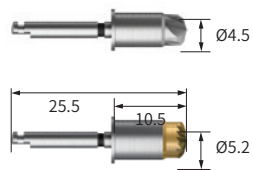
Flattening Drill				
Description	D/Ø	Regular Hole (Ø5.1)	Wide Hole (Ø5.8)	Image/Guide
<ul style="list-style-type: none"> Used for flattening narrow or irregular bone ridges, before initial drill Multiple cutting edge designed to prevent drill bouncing 2 Types (Below F5.0/for F5.0) Recommended speed: 800 ~ 1,200 rpm 	Ø4.5	HOGFD45	-	
	Ø5.2	-	HOGFD52WC	

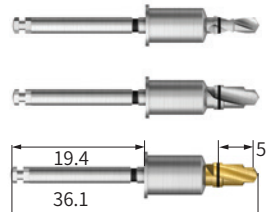
Initial Drill				
Description	D/Ø	Regular Hole (Ø5.1)	Wide Hole (Ø5.8)	Image/Guide
<ul style="list-style-type: none"> Used after Tissue Punch for initial drilling Secures depth for subsequent drills for more stability Available in 3 types: (F3.5 soft bone/below F5.0/for 5.0) Recommended speed: 800 ~ 1,200 rpm 	Ø3.5 (Soft)	HOGID2206II	-	
	Ø4.0/Ø4.5	HOGID2206I	-	
	Ø5.0 (W)	-	HOGID2206IWC	

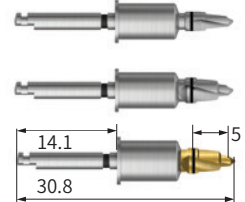
Initial Drill (Short Type)				
Description	D/Ø	Regular Hole (Ø5.1)	Wide Hole (Ø5.8)	Image/Guide
<ul style="list-style-type: none"> Short type Initial Drill (5.3mm shorter) Used for limited intermaxillary space Available in 3 types: (F3.5 soft bone/below F5.0/for 5.0) Recommended speed: 800 ~ 1,200 rpm 	Ø3.5 (Soft)	HOGD2206IIS	-	
	Ø4.0/Ø4.5	HOGD2206IS	-	
	Ø5.0 (W)	-	HOGD2206ISWC	

OneGuide Kit Surgical Kit Instruments

OneGuide Drill							
Description/Item code							
<ul style="list-style-type: none"> Taper Drill optimized for III/IV type implant Used for placing F3.5 ~ F5.0 & 6 ~ 13mm implants Multi-step drill design allows for stable drilling Drills for 6mm and F5.5(W) types are sold separately Recommended speed: Soft Bone (800 ~ 1,200 rpm) / Normal, Hard Bone (1,200 ~ 1,500 rpm) 							
Below F5.0 Regular Hole (Ø5.1)		D/Ø	Ø3.5	Ø4.0	Ø4.5	Image/Guide	
		Y-Dim.	0.7	0.9	1.0		
L	TL	GD	5.0	5.0	5.0		
6	36.1		HOGTPD3506	HOGTPD4006	HOGTPD4506		
7	36.1		HOGTPD3507	HOGTPD4007	HOGTPD4507		
8.5	36.1		HOGTPD3508	HOGTPD4008	HOGTPD4508		
10	36.1		HOGTPD3510	HOGTPD4010	HOGTPD4510		
11.5	37.6		HOGTPD3511	HOGTPD4011	HOGTPD4511		
13	39.1		HOGTPD3513	HOGTPD4013	HOGTPD4513		
F5.0 Wide Hole (Ø5.8)		D/Ø	Ø3.5 (w)	Ø4.5 (w)	Ø5.0 (w)	Ø5.5 (w)	Image/Guide
		Y-Dim.	0.7	0.9	1.0	1.0	
L	TL	GD	5.7	5.7	5.7	5.7	
6	36.1		HOGTPD3506WC	HOGTPD4506WC	HOGTPD5006WC	HOGTPD5506WC	
7	36.1		HOGTPD3507WC	HOGTPD4507WC	HOGTPD5007WC	HOGTPD5507WC	
8.5	36.1		HOGTPD3508WC	HOGTPD4508WC	HOGTPD5008WC	HOGTPD5508WC	
10	36.1		HOGTPD3510WC	HOGTPD4510WC	HOGTPD5010WC	HOGTPD5510WC	
11.5	37.6		HOGTPD3511WC	HOGTPD4511WC	HOGTPD5011WC	HOGTPD5511WC	
13	39.1		HOGTPD3513WC	HOGTPD4513WC	HOGTPD5013WC	HOGTPD5513WC	

Twist Drill						
Description		F3.5 Soft Bone Regular Hole (Ø5.1)		D/Ø	Ø2.2	Image/Guide
<ul style="list-style-type: none"> Used to place F3.5 implants in soft bone Available in 5 types Recommended speed: 800 ~ 1,200 rpm 				Y-Dim.	0.7	
		L	TL	GD	5.0	
		7	36.1		HOGTD2207	
		8.5	36.1		HOGTD2208	
		10	36.1		HOGTD2210	
		11.5	37.6		HOGTD2211	
13	39.1		HOGTD2213			

OneGuide Kit Surgical Kit Instruments



OneGuide Vertical Twist Drill				
Description	D/Ø	Regular Hole (Ø5.1)	Wide Hole (Ø5.8)	Image/Guide
<ul style="list-style-type: none"> Used for drilling before OneGuide Anchor Sold as an individual item Recommended speed: 800 ~1,200 rpm 	Ø1.5	HOGTD1506	HOGTD1506W	



OneGuide Vertical Bone Anchor				
Description	D/Ø	Regular Hole (Ø5.1)	Wide Hole (Ø5.8)	Image/Guide
<ul style="list-style-type: none"> Used for fixing the OneGuide in place (e. g. edentulous case) Mounted on the alveolar bone vertically to fix OneGuide in place Soft bone: placed directly Normal/hard bone: placed after using the OneGuide Vertical Drill Tighten at 20 rpm with Anchor Driver Sold as an individual item 	Ø2.0	HOGBAR	HOGBAW	



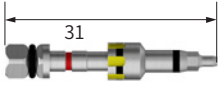

OneGuide Vertical Implant Anchor				
Description	D/Ø	Regular Hole (Ø5.1)	Wide Hole (Ø5.8)	Image/Guide
<ul style="list-style-type: none"> Used for fixing OneGuide in place (e. g. edentulous case) Mounted on the implant vertically to fix OneGuide in place Tighten with 1.2 hex Hand Driver Only used for Regular connection of F4.0 or greater Sold as an individual item 	Ø2.0	HOGFAR	HOGFAW	

OneGuide NoMount Driver for ET				
Description	*C	D/Ø	Item code	Image/Guide
<ul style="list-style-type: none"> Used to place a NoMount implant It is recommended to place the implant ~80% of the planned implant depth with this driver C = Connection 	F3.5	Mini Regular Hole (Ø5.1)	HOGNMDM50	
	F4.0/4.5	Regular Regular Hole (Ø5.1)	HOGNMDR50	
	F5.0	Regular Wide Hole (Ø5.8)	HOGNMDR57	

OneGuide Kit Surgical Kit Instruments

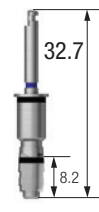

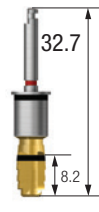
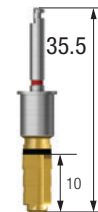
OneGuide Implant Driver for ET				
Description	*C	D/Ø	Item code	Image/Guide
<ul style="list-style-type: none"> Used with a wrench for finishing the final implant placement Yellow groove aligns the abutment hex direction Match the grooves on the OneGuide template with the grooves on the driver C = Connection 	F3.5	Mini Regular Hole (Ø5.1)	HOGFDM50	
	F4.0/4.5	Regular Regular Hole (Ø5.1)	HOGFDR50	
	F5.0 (W)	Regular Wide Hole (Ø5.8)	HOGFDR57	



Implant Driver (Stopper Type)				
Description	*C	D/Ø	Item code	Image/Guide
<ul style="list-style-type: none"> Featuring stopper design to prevent entry below the upper surface of OneGuide hole Sold as an individual item C = Connection 	F3.5	Mini Regular Hole (Ø5.1)	HOGFDSM50	
	F4.0/4.5	Regular Regular Hole (Ø5.1)	HOGFDSR50	
	F5.0 (W)	Regular Wide Hole (Ø5.8)	HOGFDSR57	

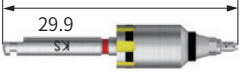

OneGuide Taper Cortical Drill				
Description	L	Regular Hole (Ø5.1)	Image/Guide	
<ul style="list-style-type: none"> Used for placing F4.5 and F5.0 implants in hard bone Optimize placement by cutting cortical bone Drills for 13 mm diameter implant is sold separately Drilling up to the first black line for 6mm placement Recommended speed: 800 ~ 1,200 rpm 	6 / 7 / 8.5mm	HOGTCD4507		32.7
	10 / 11.5mm	HOGTCD4510		33.7
	13mm	HOGTCD4513		37.2
				8.2
				8.2
				11.7
	6~8.5mm			
	10~11.5mm			
	13mm			
	L	Wide Hole (Ø5.8)		
	6 / 7 / 8.5mm	HOGTCD5007WC		32.7
	10 / 11.5mm	HOGTCD5010WC		35.5
	13mm	HOGTCD5013WC		38.3
			8.2	
			10	
			13	
6~8.5mm				
10~11.5mm				
13mm				

OneGuide Kit Surgical Kit Instruments

OneGuide No Mount Driver for EK				
Description	*C	D/Ø	Item code	Image/Guide
<ul style="list-style-type: none"> Used for placing EK NoMount Implants Recommended to place ~80% of the planned implant depth with this driver Sold as an individual item C = Connection 	F3.5	Regular Regular Hole (Ø5.1)	HOGNMDM50K	
	F4.0/4.5		HOGNMDR50K	
	F5.0	Regular Wide Hole (Ø5.8)	HOGNMDR57K	

OneGuide Implant Driver for EK				
Description	*C	D/Ø	Item code	Image/Guide
<ul style="list-style-type: none"> Used with a wrench for finishing the final implant placement Yellow groove aligns the abutment hex direction Match the grooves on the OneGuide template with the grooves on the driver Sold as an individual item C = Connection 	F3.5	Regular Regular Hole (Ø5.1)	HOGFDM50K	
	F4.0/4.5		HOGFDR50K	
	F5.0	Regular Wide Hole (Ø5.8)	HOGFDR57K	

OneGuide NoMount Driver for SS					
Description	*P	D/Ø	Item code	Image	
<ul style="list-style-type: none"> Used for placing SS NoMount Implants Recommended to place ~80% of the planned implant depth with this driver *P = Platform 	F3.5/F4.0/4.5	Mini Regular Hole (Ø5.1)	HOGNMDR50S		
	F5.0	Regular Wide Hole (Ø5.8)	HOGNMDR57S		
	F5.0	Wide Extra Wide Hole (Ø6.8)	HOGNMDW67S		

OneGuide Implant Driver for SS					
Description	*P	D/Ø	Item code	Image	
<ul style="list-style-type: none"> Used with a wrench for finishing the final implant placement Yellow groove aligns the abutment hex direction Match the grooves on the OneGuide template with the grooves on the driver Sold as an individual item *P = Platform 	F3.5/F4.0/4.5	Mini Regular Hole (Ø5.1)	HOGFDR50S		
	F5.0	Regular Wide Hole (Ø5.8)	HOGFDR57S		
	F5.0	Wide Extra Wide Hole (Ø6.8)	HOGFDW67S		

OneGuide Kit Surgical Kit Instruments

OneGuide Path Drill					
Description	L		Regular Hole (Ø5.1)	Wide Hole (Ø5.8)	Image/Guide
<ul style="list-style-type: none"> • Drill for correcting path deviation during OneGuide surgery • Used for creating implant placement path for extraction cases • Flat blade design optimized for cutting inclined bone • 4 types for each Oneguide hole diameter, 8 types in total: Regular hole (Ø5.1) / Wide hole (Ø5.8) • For 13mm drills, depth is adjusted according to the black lines • Recommended speed: 1,200 ~ 1,500 rpm 	7	Ø2.5	HOGSD2507	HOGSD2507WC	
		Ø3.0	HOGSD3007	HOGSD3007WC	
	13	Ø2.5	HOGSD2513	HOGSD2513WC	
		Ø3.0	HOGSD3013	HOGSD3013WC	

Anchor Screw		
Description	Item Code	Image
<ul style="list-style-type: none"> • Used to affix the OneGuide firmly • Selectable at the preoperative planning stage 	HQGAS18	

Anchor Drill		
Description	Item Code	Image
<ul style="list-style-type: none"> • Used for drilling before using anchor screw • Recommended speed: 800 ~ 1,200 rpm 	HQGATD13	

OneGuide Anchor Driver (Mount Driver)		
Description	Item Code	Image
<ul style="list-style-type: none"> • Used to place anchor screw 	HASMDS	

Drilling Sequence OneGuide Drill

EKIII | ETIII

(Length: 10mm)

Ø3.5

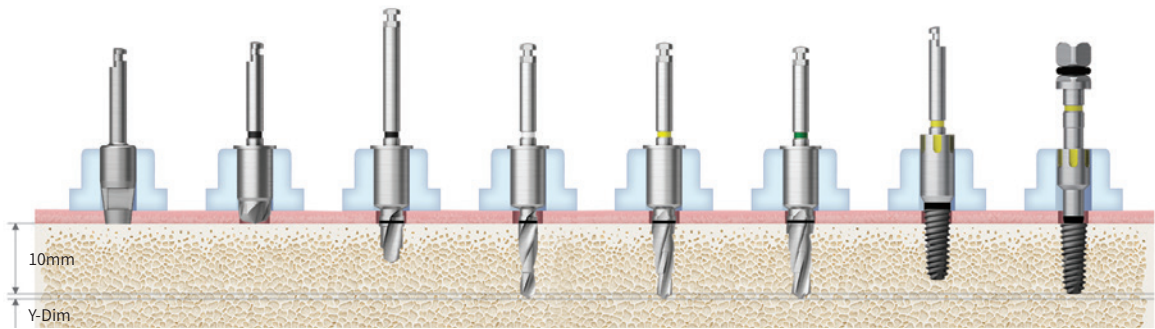

Bone Quality	Tissue Punch	Flattening Drill	Initial Drill	Drill (Ø2.2)	Drill (F3.5)	Drill (F4.0)	Nomount Driver	Implant Driver
Soft	▶	(▶)	(F3.5 Soft)▶	▶				
Normal	▶	(▶)	▶		▶		Implant Placement (Up to 80%)	Implant Placement
Hard	▶	(▶)	▶		▶	▶		

Ø4.0

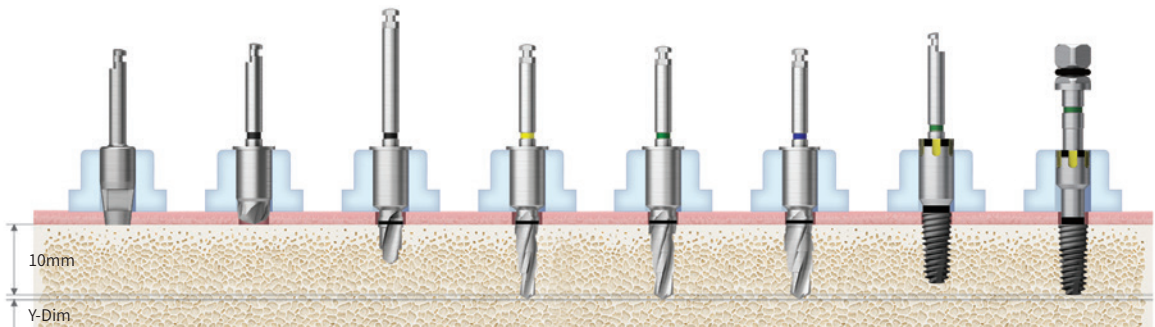

Bone Quality	Tissue Punch	Flattening Drill	Initial Drill	Drill (F3.5)	Drill (F4.0)	Drill (F4.5)	Nomount Driver	Implant Driver
Soft	▶	(▶)	▶	▶				
Normal	▶	(▶)	▶	▶	▶		Implant Placement (Up to 80%)	Implant Placement
Hard	▶	(▶)	▶	▶		▶		

Ø4.5

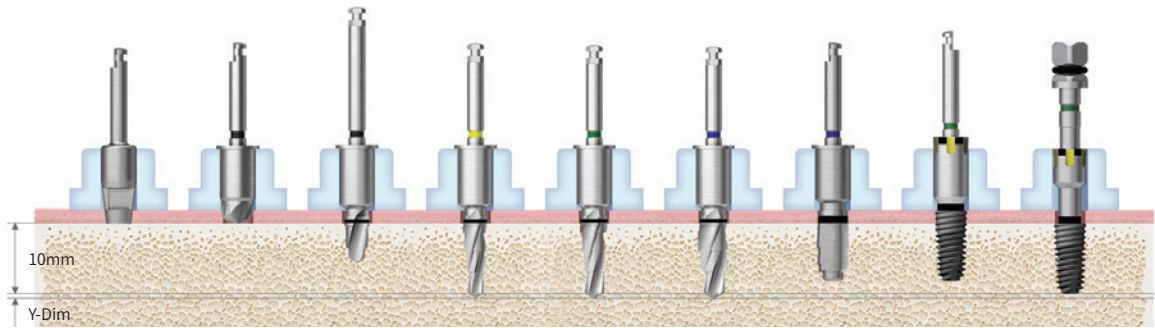

Bone Quality	Tissue Punch	Flattening Drill	Initial Drill	Drill (F3.5)	Drill (F4.0)	Drill (F4.5)	Cortical (F4.5)	Nomount Driver	Implant Driver
Soft	▶	(▶)	▶	▶	▶				
Normal	▶	(▶)	▶	▶		▶		Implant Placement (Up to 80%)	Implant Placement
Hard	▶	(▶)	▶	▶		▶	▶		

Drilling Sequence OneGuide Drill

EKIII | ETIII

(Length: 10mm)

Ø5.0

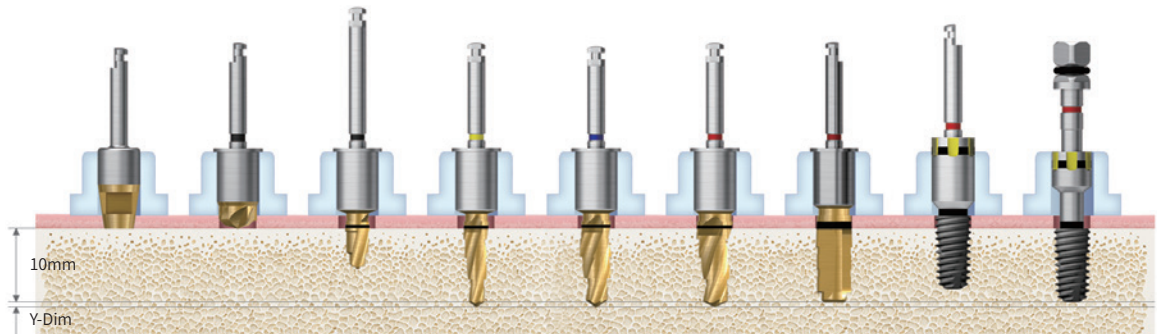

Bone Quality	Tissue Punch (W)	Flattening Drill (W)	Initial Drill (W)	Drill (W) (F3.5)	Drill (W) (F4.5)	Drill (W) (F5.0)	Cortical (W) (F5.0)	Nomount Driver	Implant Driver
Soft	▶	(▶)	▶	▶	▶				
Normal	▶	(▶)	▶	▶		▶		Implant Placement (Up to 80%)	Implant Placement
Hard	▶	(▶)	▶	▶		▶	▶		

※ For extra short implants (Ø4.0, Ø4.5 / 6mm) only

Ø4.0

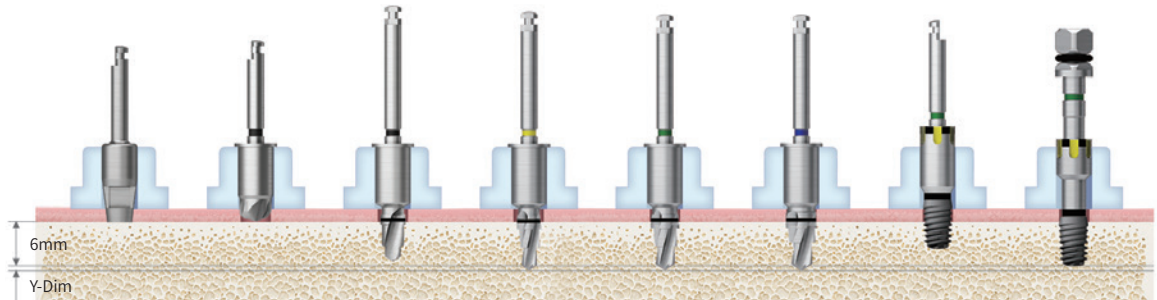

Bone Quality	Tissue Punch	Flattening Drill	Initial Drill	Drill (F3.5)	Drill (F4.0)	Drill (F4.5)	Cortical (F4.5)	Nomount Driver	Implant Driver
Soft	▶	(▶)	▶	F3.5x6					
Normal	▶	(▶)	▶	F3.5x6	F4.0x6			Implant Placement (Up to 80%)	Implant Placement
Hard	▶	(▶)	▶	F3.5x6		F4.5x6			

Ø4.5

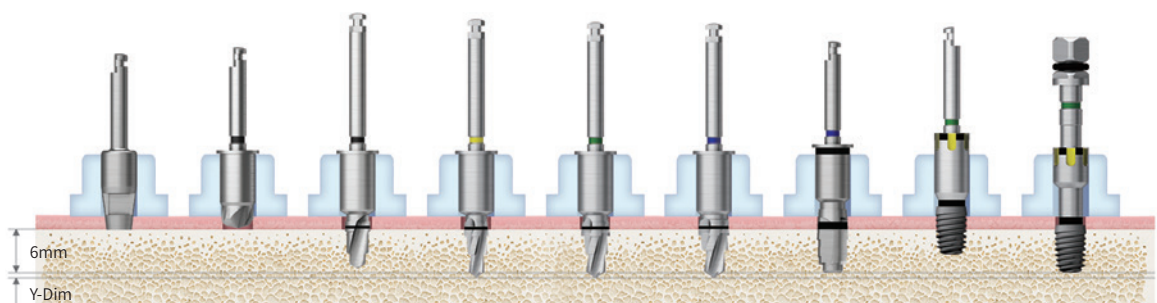

Bone Quality	Tissue Punch	Flattening Drill	Initial Drill	Drill (F3.5)	Drill (F4.0)	Drill (F4.5)	Cortical (F4.5)	Nomount Driver	Implant Driver
Soft	▶	(▶)	▶	F3.5x6	F4.0x6				
Normal	▶	(▶)	▶	F3.5x6		F4.5x6		Implant Placement (Up to 80%)	Implant Placement
Hard	▶	(▶)	▶	F3.5x6		F4.5x6	F4.5x6~8.5		

ETIV

(Length: 10mm)

Ø4.0

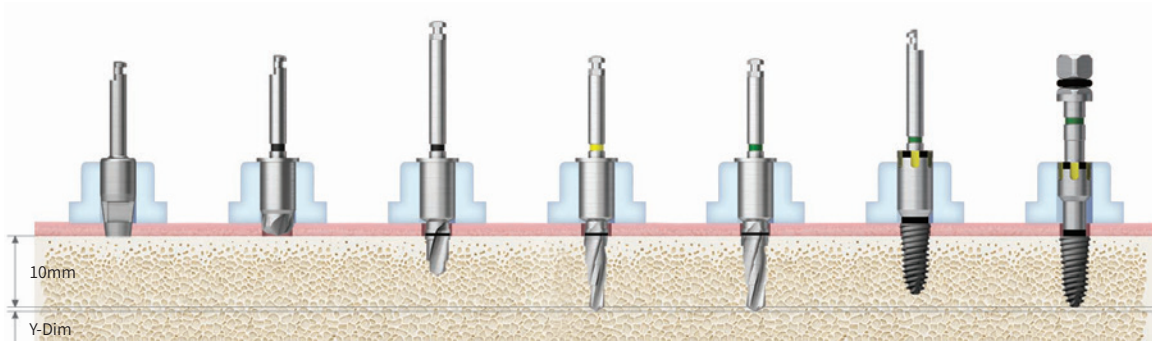

Bone Quality	Tissue Punch	Flattening Drill	Initial Drill	Drill (F3.5)	Drill (F4.0)	Nomount Driver	Implant Driver
Soft	▶	(▶)	▶	▶		Implant Placement (Up to 80%)	Implant Placement
Normal	▶	(▶)	▶	▶	▶		

Ø4.5

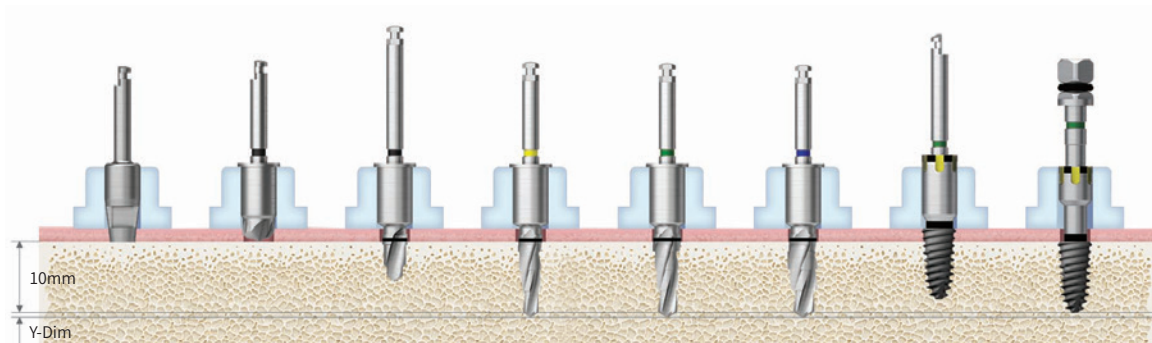

Bone Quality	Tissue Punch	Flattening Drill	Initial Drill	Drill (F3.5)	Drill (F4.0)	Drill (F4.5)	Nomount Driver	Implant Driver
Soft	▶	(▶)	▶	▶	▶		Implant Placement (Up to 80%)	Implant Placement
Normal	▶	(▶)	▶	▶		▶		

Ø5.0

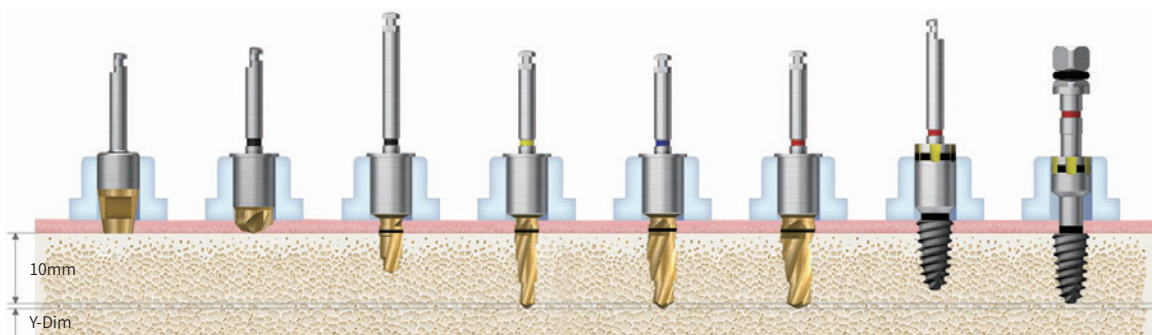

Bone Quality	Tissue Punch (W)	Flattening Drill (W)	Initial Drill (W)	Drill (W) (F3.5)	Drill (W) (F4.5)	Drill (W) (F5.0)	Nomount Driver	Implant Driver
Soft	▶	(▶)	▶	▶	▶		Implant Placement (Up to 80%)	Implant Placement
Normal	▶	(▶)	▶	▶		▶		

HIOSSEN
IMPLANT

OneCAS Kit (HOCK)

For

EKIII

ETIII/IV

Hydraulic Membrane Lifter Tube
SNMT



Bone Condenser
SNBC1114



Top panel components

Depth Gauge
HCDG



Depth Gauge(W)
HCDGW



Lower panel components

Bone Carrier Head
SNBCH30



Bone Carrier
SNBCS35

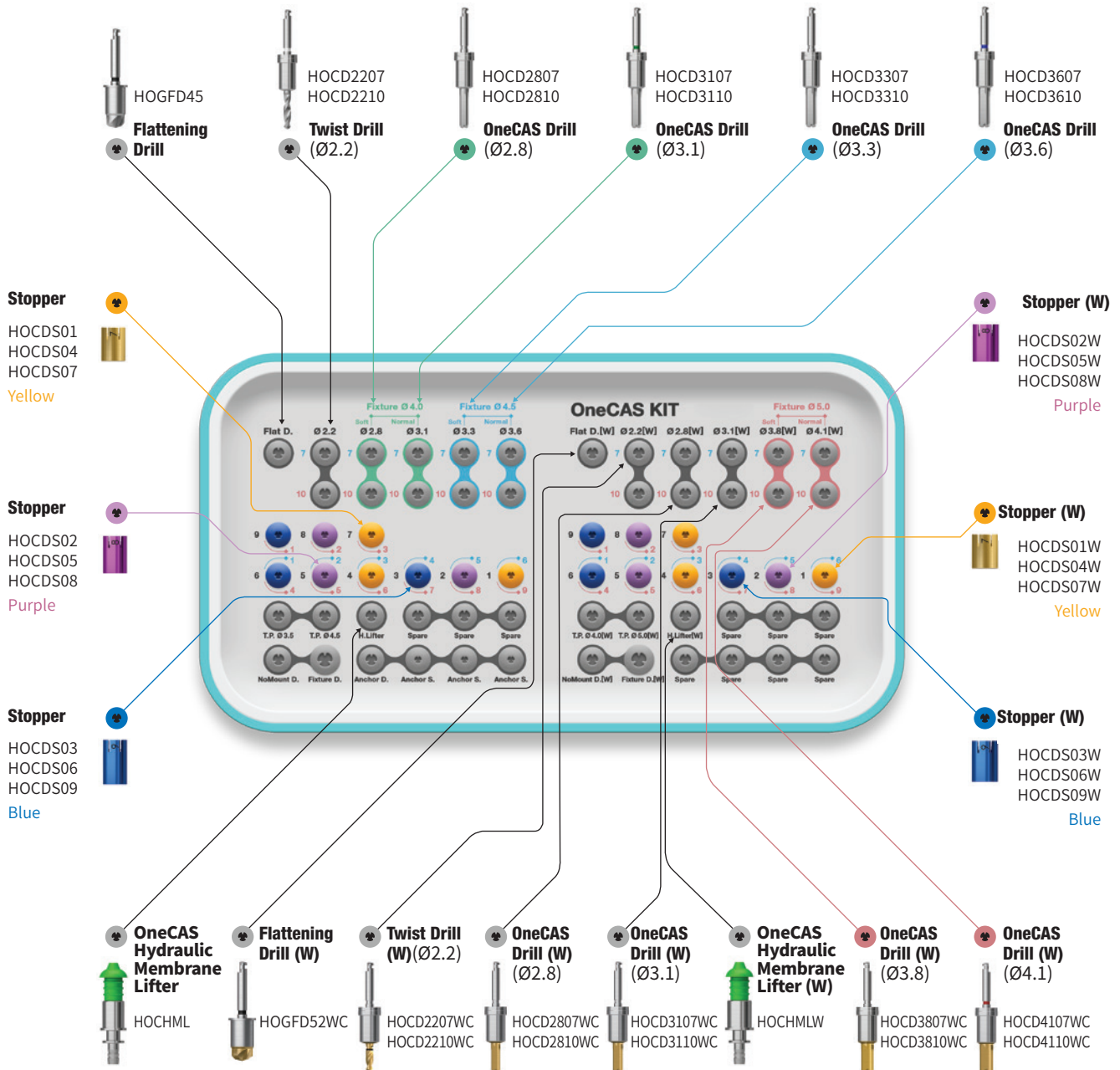

OneCAS Kit Surgical Kit Instruments

OneCAS Twist Drill					
<ul style="list-style-type: none"> Recommended to drill 1mm under the lower margin of maxillary sinus Used with a stopper for a safe membrane approach 1mm shorter than a normal Twist Drill Recommended speed: 400 ~ 1,200 rpm 					
		F4.0/4.5		F5.0 (W)	
Y-Dim		0.6			
GD		5.0		5.7	
TL	L	D/Ø			
33.2	7	Ø2.2		HOCD2207	
36.2	10			HOCD2210	

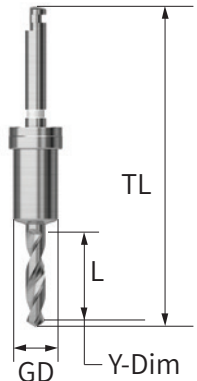



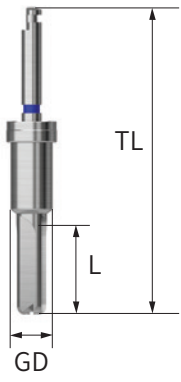





OneCAS Twist Drill					
<ul style="list-style-type: none"> Used with the stopper of OneCAS system The membrane is safely lifted during maxillary sinus surgery Possible to collect autogenous bone at low RPM's Use a stopper for a safe membrane approach Final drill diameter selection based on bone quality Recommended rpm: 400~800rpm 					
F4.0/4.5		Ø2.8	Ø3.1	Ø3.3	Ø3.6
L	TL	5.0			
7	33.6	HOCD2807	HOCD3107	HOCD3307	HOCD3607
10	36.1	HOCD2810	HOCD3110	HOCD3310	HOCD3610
F5.0 (W)		Ø2.8	Ø3.1	Ø3.8	Ø4.1
L	TL	5.0			
7	33.6	HOCD2807WC	HOCD3107WC	HOCD3807WC	HOCD4107WC
10	36.6	HOCD2810WC	HOCD3110WC	HOCD3810WC	HOCD4110WC



OneCAS Kit Surgical Kit Instruments

OneCAS Stopper

- Stopper number indicates the length when engaged
- On the kit, protruding length marked in blue for 7mm drills and in red for 10mm drills
- Color coded by length
- Recommended number of use: 50 times

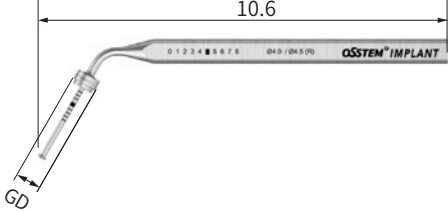

Diameter	1	2	3	4	5	6	7	8	9
									
F4.0/4.5	HOCD01	HOCD02	HOCD03	HOCD04	HOCD05	HOCD06	HOCD07	HOCD08	HOCD09
F5.0 (W)	HOCD01W	HOCD02W	HOCD03W	HOCD04W	HOCD05W	HOCD06W	HOCD07W	HOCD08W	HOCD09W
Color	Yellow	Purple	Blue	Yellow	Purple	Blue	Yellow	Purple	Blue

Depth Gauge

Description		F4.0/4.5	F5.0 (W)	Image/Guide
	GD	5.0	5.7	
<ul style="list-style-type: none"> • Checks for internal sinus lift • Measures residual bone depth • Use with a stopper for safer approach • Same depth marking lines as a 10mm drill 		HCDG	HCDGW	

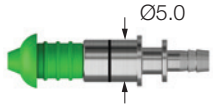
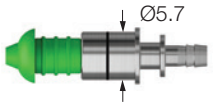
OneCAS Kit Surgical Kit Instruments

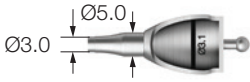
Hydraulic Membrane Lifter			
Description	D/Ø	Item code	Image/Guide
<ul style="list-style-type: none"> Dedicated bone delivery instrument for the OneCAS Kit Inserted into the OneGuide hole following initial marking and drilling Thin-wall design optimizes sealing during flapless procedures 	Regular Hole (Ø5.1)	OCHML	
	Wide Hole (Ø5.8)	OCHMLW	

Bone Carrier Head			
Description	D/Ø	Item code	Image/Guide
<ul style="list-style-type: none"> Dedicated bone delivery instrument for the OneCAS Kit Inserted and fixed up to the end of the OneGuide hole during use OCBCH30: Used after OneCAS drill Ø3.1 OCBCH32: Used after OneCAS drill Ø3.3 / Ø3.6 CBCH37W: Used after OneCAS drill Ø3.8 / Ø4.1 After filling bone material up to the head marking line, use with a bone condenser to completely deliver bone into the sinus cavity, then repeat as needed 	Regular Hole (Ø5.1)	OCBCH30	
		OCBCH32	
	Wide Hole (Ø5.8)	OCBCH37W	

Bone Carrier		
Description	Item Code	Image
<ul style="list-style-type: none"> Dedicated bone delivery instrument for the OneCAS KIT The head is secured by tightening the rear handle of the body The head can be replaced and used interchangeably 	OCBCS30	

Drilling Sequence OneCAS Kit

Residual Bone **3mm**
Ø4.0

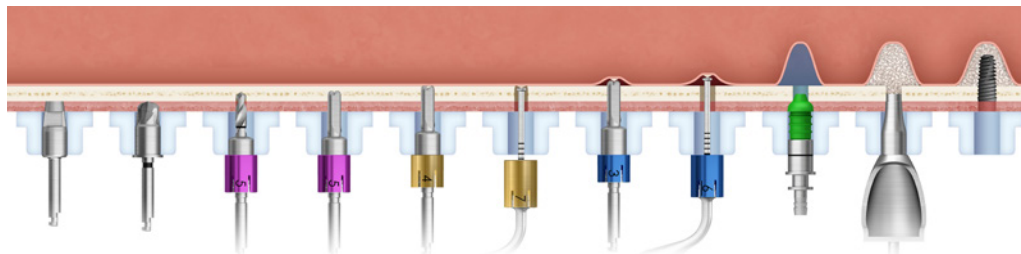

Bone Quality	Tissue Punch	Flattening Drill	Twist Drill (Ø2.2x7)	OneCAS Drill	OneCAS Drill	Depth Gauge	OneCAS Drill	Depth Gauge	Hydraulic Lifter	Bone Carrier	Implant
Soft	▶	▶	▶	Ø2.8x7	Ø2.8x7	▶	Ø2.8x7	▶	▶	▶	▶
Normal	▶	▶	▶	Ø3.1x7	Ø3.1x7	▶	Ø3.1x7	▶	▶	▶	▶
Stopper			5	5	4	7	3	6			

Residual Bone **3mm**
Ø4.5

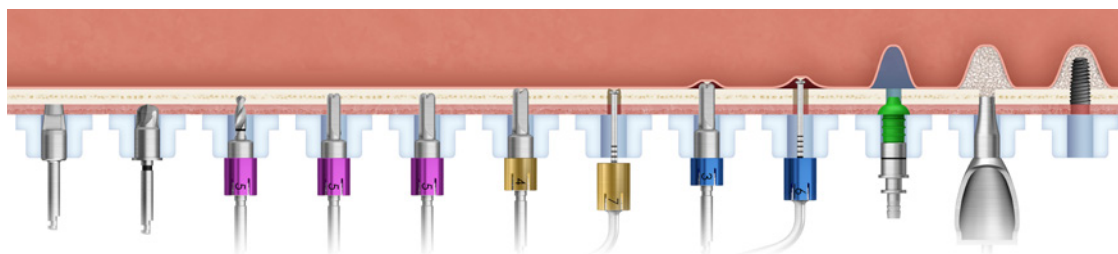

Bone Quality	Tissue Punch	Flattening Drill	Twist Drill (Ø2.2x7)	OneCAS Drill	OneCAS Drill	OneCAS Drill	Depth Gauge	OneCAS Drill	Depth Gauge	Hydraulic Lifter	Bone Carrier	Implant
Soft	▶	▶	▶	Ø2.8x7	Ø3.3x7	Ø3.3x7	▶	Ø3.3x7	▶	▶	▶	▶
Normal	▶	▶	▶	Ø3.1x7	Ø3.6x7	Ø3.6x7	▶	Ø3.6x7	▶	▶	▶	▶
Stopper			5	5	5	4	7	3	6			

Residual Bone **3mm**
Ø5.0

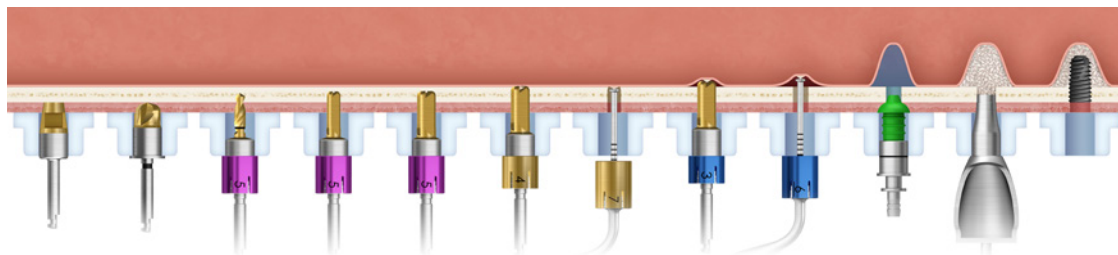

Bone Quality	Tissue Punch(W)	Flattening Drill(W)	Twist Drill (Ø2.2x7)(W)	OneCAS Drill(W)	OneCAS Drill(W)	OneCAS Drill(W)	Depth Gauge(W)	OneCAS Drill(W)	Depth Gauge(W)	Hydraulic Lifter(W)	Bone Carrier(W)	Implant
Soft	▶	▶	▶	Ø2.8x7	Ø3.8x7	Ø3.8x7	▶	Ø3.8x7	▶	▶	▶	▶
Normal	▶	▶	▶	Ø3.1x7	Ø4.1x7	Ø4.1x7	▶	Ø4.1x7	▶	▶	▶	▶
Stopper (W)			5	5	5	4	7	3	6			

Drilling Sequence OneCAS Kit

Residual Bone 8mm
Ø4.0

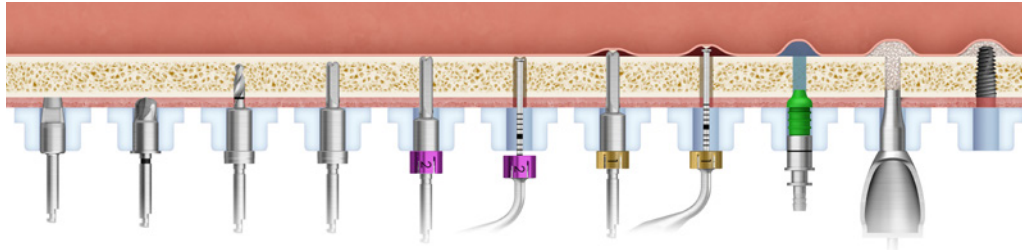

Bone Quality	Tissue Punch	Flattening Drill	Twist Drill (Ø2.2x7)	OneCAS Drill	OneCAS Drill	Depth Gauge	OneCAS Drill	Depth Gauge	Hydraulic Lifter	Bone Carrier	Implant
Soft	▶	▶	▶	Ø2.8x7	Ø2.8x10	▶	Ø2.8x10	▶	▶	▶	▶
Normal	▶	▶	▶	Ø3.1x7	Ø3.1x10	▶	Ø3.1x10	▶	▶	▶	▶
Stopper					2	2	1	1			

Residual Bone 8mm
Ø4.5

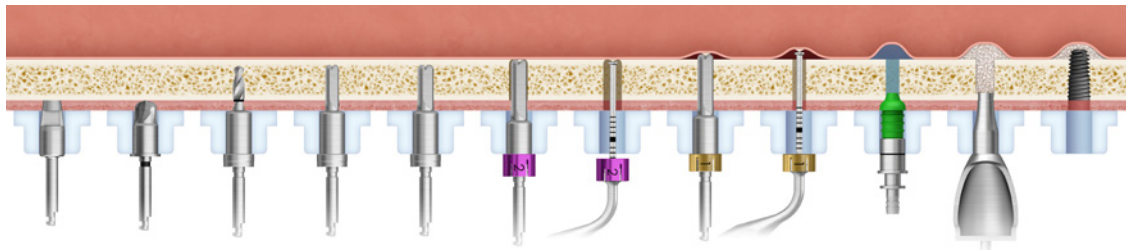

Bone Quality	Tissue Punch	Flattening Drill	Twist Drill (Ø2.2x7)	OneCAS Drill	OneCAS Drill	OneCAS Drill	Depth Gauge	OneCAS Drill	Depth Gauge	Hydraulic Lifter	Bone Carrier	Implant
Soft	▶	▶	▶	Ø2.8x7	Ø3.3x7	Ø3.3x10	▶	Ø3.3x10	▶	▶	▶	▶
Normal	▶	▶	▶	Ø3.1x7	Ø3.6x7	Ø3.6x10	▶	Ø3.6x10	▶	▶	▶	▶
Stopper						2	2	1	1			

Residual Bone 8mm
Ø5.0

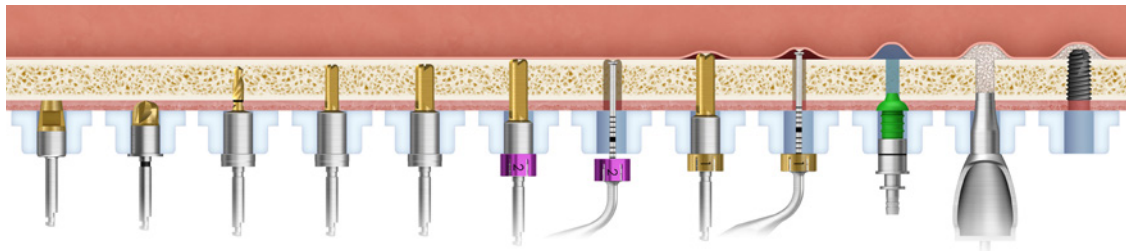

Bone Quality	Tissue Punch(W)	Flattening Drill(W)	Twist Drill (Ø2.2x7)(W)	OneCAS Drill(W)	OneCAS Drill(W)	OneCAS Drill(W)	Depth Gauge(W)	OneCAS Drill(W)	Depth Gauge(W)	Hydraulic Lifter(W)	Bone Carrier(W)	Implant
Soft	▶	▶	▶	Ø2.8x7	Ø3.8x7	Ø3.8x10	▶	Ø3.8x10	▶	▶	▶	▶
Normal	▶	▶	▶	Ø3.1x7	Ø4.1x7	Ø4.1x10	▶	Ø4.1x10	▶	▶	▶	▶
Stopper (W)						2	2	1	1			

OneEM Kit (HOMSK)

For

- EKIII
- ETIII/IV
- EM(MS)

Top panel components

Torque Wrench
TQWCB



Depth Gauge
HMDTGG

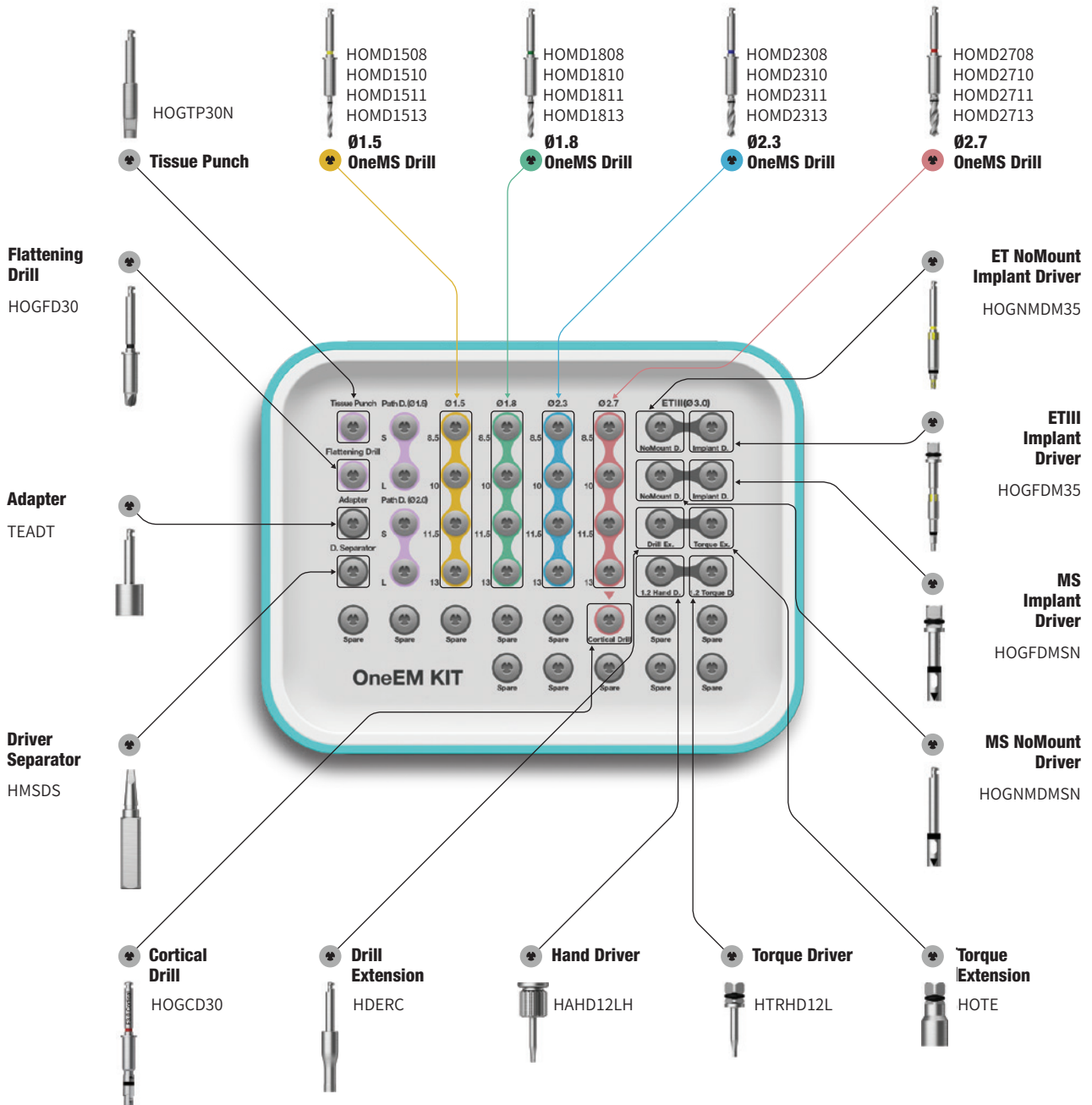

OneEM Kit Surgical Kit Instruments

OneGuide Template	
Description/Item code	Image/Guide
<ul style="list-style-type: none"> Two sizes of guide holes depending on the diameter of the implant <ul style="list-style-type: none"> - D5.0 for implant diameters: F3.5/4.0/4.5 - D5.8 for implant diameter: F5.0 Dual contact feature ensures excellent accuracy in positioning and stability Simple drilling sequence by adopting 122 Taper Kit concepts Packing unit: surgical guide <ul style="list-style-type: none"> (optional: SmartFit abutment, Temporary Crown) 	

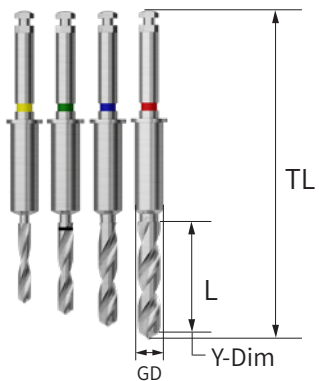
OneEM Drill										
Description/Item code			Image/Guide							
<ul style="list-style-type: none"> Straight type drills for EM implant / ETIII Ø3.2 implants (EM Ø2.0 ~ Ø3.0 / ETIII Ø3.2 implants) OneMS Cortical Drill is used for placing ETIII Ø3.2 implants in hard bones Start with 8.5mm drill for stable drilling Recommended speed: 800 ~ 1,200 rpm 										
L	TL	D/Ø	Ø1.5	Ø1.8	Ø2.3	Ø2.7				
		GD	0.6	0.6	0.6	0.6				
8.5	37.5		HOMD1508	HOMD1808	HOMD2308	HOMD2708				
10	39		HOMD1510	HOMD1810	HOMD2310	HOMD2710				
11.5	40.5		HOMD1511	HOMD1811	HOMD2311	HOMD2711				
13	42		HOMD1513	HOMD1813	HOMD2313	HOMD2713				
Color			Yellow	Green	Blue	Pink				

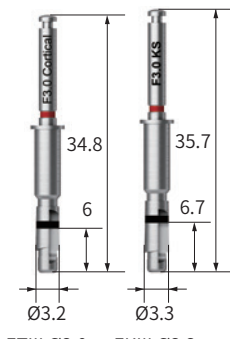
OneEM Cortical Drill	
Description/Item code	Image
<ul style="list-style-type: none"> Used to remove cortical bone in hard bone Used for expanding the cortical bone after using the Straight Drill (ETIII Ø3.0 only) Recommended speed: 800 ~ 1,200 rpm 	
ETIII Ø3.0	EKIII Ø3.3
HOGCD30	HOGCD30K

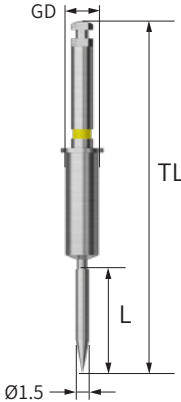
OneEM Lance Drill				
Description/Item code			Image/Guide	
<ul style="list-style-type: none"> Creates holes in the bone to facilitate initial drilling Bone density can be determined through drilling Single item (excluded from OneMS Kit) 				
L	TL	D/Ø	Ø1.5	
8.5	37.5		HOMLD1508	
10	39		HOMLD1510	
11.5	40.5		HOMLD1511	
13	42		HOMLD1513	

OneEM Kit Surgical Kit Instruments

Flattening Drill	
Description/Item code	Image
<ul style="list-style-type: none"> Used for narrow or uneven ridges Cutting edge design allows for stable bone removal 	
HOGFD30	

Driver Separator	
Description/Item code	Image
<ul style="list-style-type: none"> Used in case a driver is wedged with the implant during insertion Insert the Driver Separator into the driver groove to loosen it from the implant 	
HMSDS	

Tissue Punch	
Description/Item code	Image
<ul style="list-style-type: none"> Used to remove gingiva to continue with flapless surgery 	
HOGTP30N	

OneEM Driver	
Description	Image
<ul style="list-style-type: none"> Used with the torque wrench for adjustment of the final implant placement for MS implant narrow ridge Match the mark with the implant 	
F2.0/2.5/3.0	
NoMount Driver	HOGMDMSN
Implant Driver	HOGFDMSN
Nomount driver	Implant driver

Implant Driver	
Description	Image
<ul style="list-style-type: none"> Used with the torque wrench for adjustment of the final implant placement Yellow grooves aligns with abutment hex direction Match the groove of OneGuide template with the groove of driver C = Connection 	
ET Ø3.2	EK Ø3.3
HOGFDM35	OGFDM35K

NoMount Driver	
Description	Image
<ul style="list-style-type: none"> Used with the torque wrench for adjustment of the final implant placement Yellow grooves aligns with abutment hex direction Match the groove of OneGuide template with the groove of driver C = Connection 	
ET Ø3.2	EK Ø3.3
HOGNMDM35	OGNMDM35K

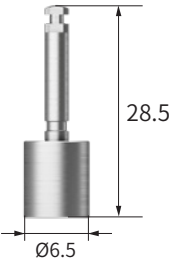
Adapter	
Description/Item code	Image
<ul style="list-style-type: none"> Use as a torque driver to connecting to the engine 	
TEADT	

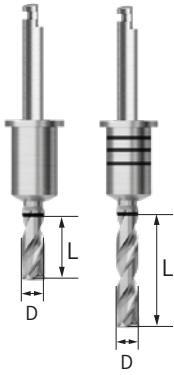
OneEM Path Drill			
Description		Image	
<ul style="list-style-type: none"> Used for correcting path deviation Can establish implant placement path during surgery For inclined bone cutting with a flat blade design For the 13mm specification, depth adjustment follows marking lines: upper line (11.5mm), middle line (10mm), lower line (8.5mm) Recommended speed: 1,200~1,500 rpm 			
L	D/Ø	Ø1.5	Ø2.0
7.0		HOMSD1507	HOMSD2007
13.0		HOMSD1513	HOMSD2013

Drilling Sequence OneEM Drill

EKIII | ETIII | EM

(Length: 10mm)

For Implant 10 / 11.5 / 13 mm sequences, an Ø8.5 mm drill must be used at each step

Ex. Ø2.5 × 11.5mm MS implant

:Tissue punch ▶ Flattening drill ▶ Ø1.8 × 8.5mm (mandatory pilot drilling) ▶ Ø1.8 × 11.5mm ▶ NoMount driver ▶ Implant driver

※ Ø1.5 drill (optional): may be selectively used for initial drilling when higher precision is required

EKIII Ø3.0

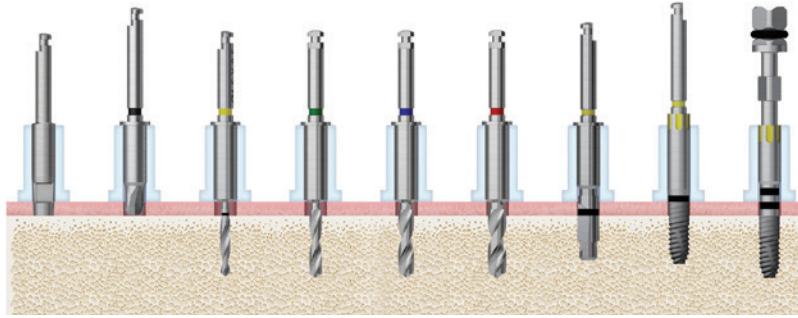

Bone Quality	Tissue Punch	Flattening Drill	OneMS Drill (Ø1.5)	OneMS Drill (Ø1.8)	OneMS Drill (Ø2.3)	OneMS Drill (Ø2.7)	F3.0 Cortical Drill	NoMount Driver	Implant Driver
Soft	▶	(▶)	(▶)	▶	▶			▶	▶
Normal	▶	(▶)	(▶)	▶	▶	▶		▶	▶
Hard	▶	(▶)	(▶)	▶	▶	▶	▶	▶	▶

ETIII Ø3.0

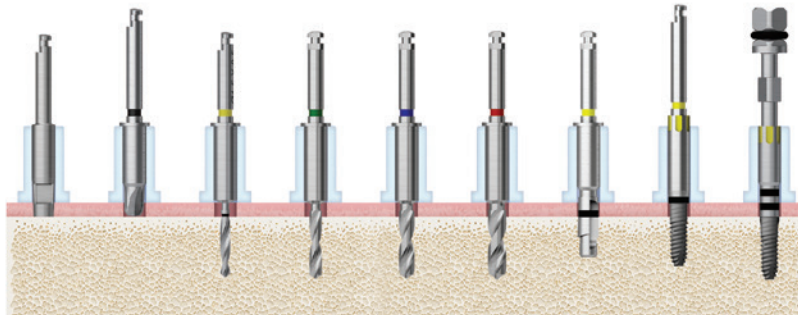

Bone Quality	Tissue Punch	Flattening Drill	OneMS Drill (Ø1.5)	OneMS Drill (Ø1.8)	OneMS Drill (Ø2.3)	OneMS Drill (Ø2.7)	F3.0 Cortical Drill	NoMount Driver	Implant Driver
Soft	▶	(▶)	(▶)	▶	▶			▶	▶
Normal	▶	(▶)	(▶)	▶	▶	▶		▶	▶
Hard	▶	(▶)	(▶)	▶	▶	▶	▶	▶	▶

EM Ø2.0

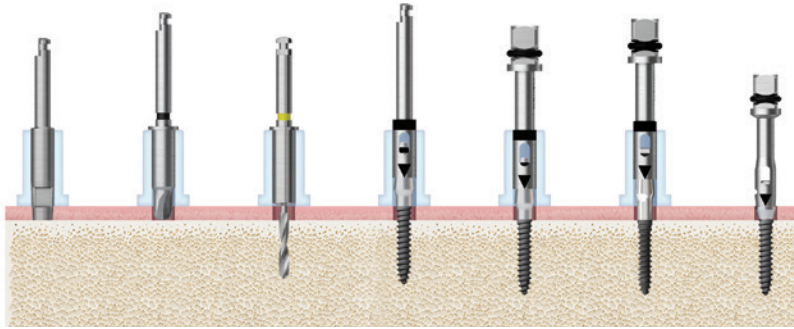

Bone Quality	Tissue Punch	Flattening Drill	OneMS Drill (Ø1.5)	NoMount Driver	Implant Driver		
					G/H 2.5	G/H 4.0	Denture
Soft	▶	(▶)	▶	▶		▶	
Normal	▶	(▶)	▶	▶		▶	
Hard	▶	(▶)	▶	▶		▶	

EM Ø2.5

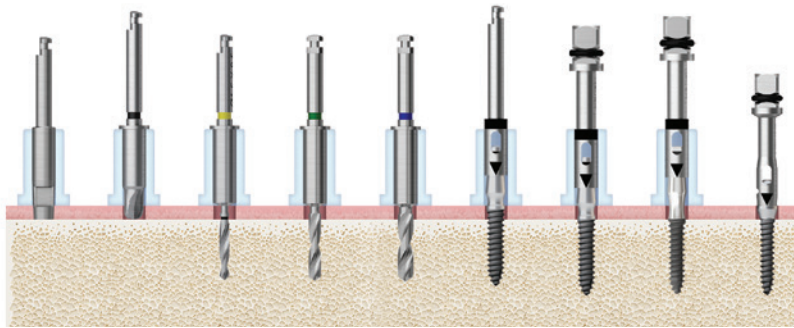

Bone Quality	Tissue Punch	Flattening Drill	OneMS Drill (Ø1.5)	OneMS Drill (Ø1.8)	OneMS Drill (Ø2.3)	NoMount Driver	Implant Driver		
							G/H 2.5	G/H 4.0	Denture
Soft	▶	(▶)	(▶)	▶	-	▶		▶	
Normal	▶	(▶)	(▶)	▶	-	▶		▶	
Hard	▶	(▶)	(▶)	▶	(▶)	▶		▶	

EM Ø3.0

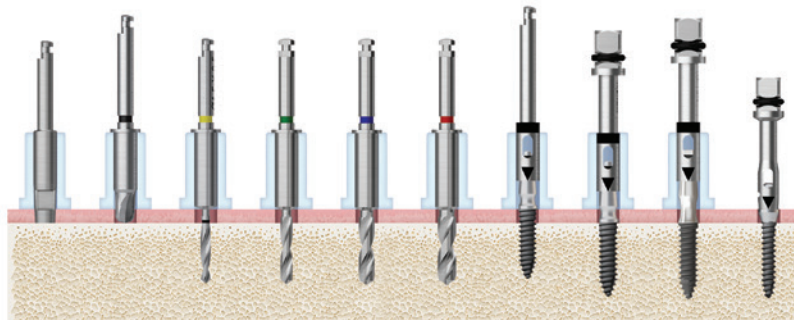

Bone Quality	Tissue Punch	Flattening Drill	OneMS Drill (Ø1.5)	OneMS Drill (Ø1.8)	OneMS Drill (Ø2.3)	OneMS Drill (Ø2.7)	NoMount Driver	Implant Driver		
								G/H 2.5	G/H 4.0	Denture
Soft	▶	(▶)	(▶)	▶	-	-	▶		▶	
Normal	▶	(▶)	(▶)	▶	-	-	▶		▶	
Hard	▶	(▶)	(▶)	▶	▶	(▶)	▶		▶	

One485 Kit (HO485K)

For

- EKIII
- ETIII/IV
- SSIII

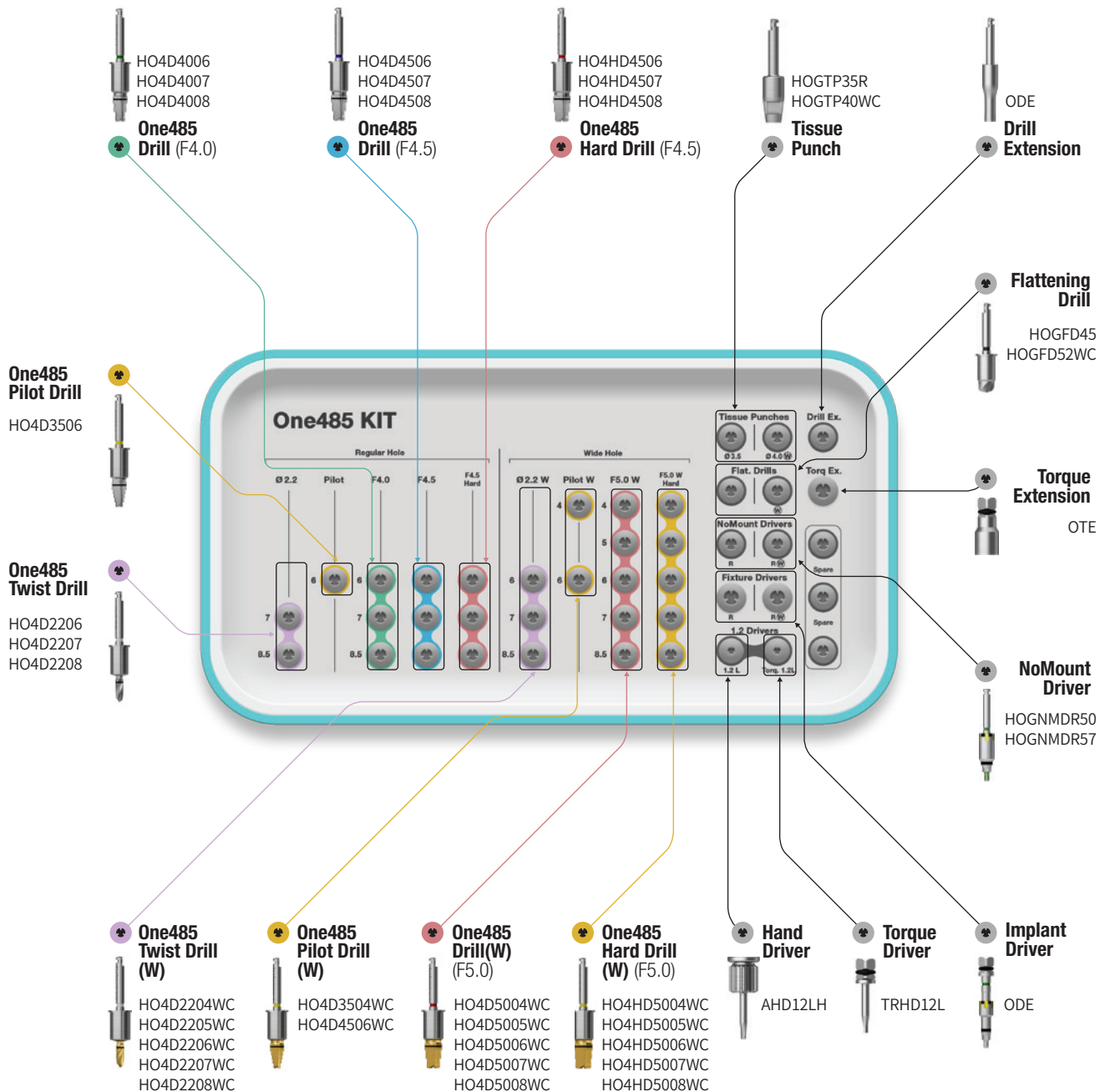
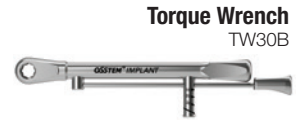

One485 Kit Surgical Kit Instruments

One485 Twist Drill				Image/Guide	
Description/Item code				Image/Guide	
<ul style="list-style-type: none"> Ensures initial drilling stability and secures the exact depth of the guide hole Straight design allows drilling to 1 mm shorter than the planned implant length Available in 8 configurations according to OneGuide hole diameter <ul style="list-style-type: none"> Regular hole (Ø5.1) / Wide hole (Ø5.8) Recommended drilling speed: 800–1,200 rpm 					
L	TL	Regular Hole(Ø5.1) F4.0 / F4.5	Wide Hole(Ø5.8) F5.0W		
4.0	30.2	-	O4D2204WC		
5.0	31.2	-	O4D2205WC		
6.0	32.2	O4D2206	O4D2206WC		
7.0	33.2	O4D2207	O4D2207WC		
8.5	34.7	O4D2208	O4D2208WC		

One485 Pilot Drill				Image/Guide	
Description/Item code				Image/Guide	
<ul style="list-style-type: none"> Expands the hole diameter during intermediate drilling Available in 3 configurations according to OneGuide hole diameter <ul style="list-style-type: none"> Regular hole (Ø5.1) / Wide hole (Ø5.8) Implant length 4–5 mm: use 4 mm, Implant length 6–8.5 mm: use 6 mm Recommended drilling speed: 800–1,200 rpm 					
L	TL	Regular Hole(Ø5.1) F4.5	Wide Hole(Ø5.8) F5.0W		
4.0	30.9	-	O4D3504WC		
6.0	32.9	O4D3506	O4D3506WC		

One485 Drill							Image/Guide	
Description/Item code							Image/Guide	
<ul style="list-style-type: none"> Used as the final drill to achieve final osteotomy diameter and optimize insertion torque Lateral cutting edges: tapered drill geometry Available in 19 configurations according to OneGuide hole diameter <ul style="list-style-type: none"> Regular hole (Ø5.1) / Wide hole (Ø5.8) For F4.5 and F5.0 implants in hard bone, use the F4.5 and F5.0 hard drills 								
L	TL	Regular Hole(Ø5.1)			Wide Hole(Ø5.8)			
		F4.0	F4.5	F4.5 Hard	F5.0W	F5.0W Hard		
4.0	30.9	-	-		O4D5004WC	O4HD5004WC		
5.0	31.9	-	-		O4D5005WC	O4HD5005WC		
6.0	32.9	O4D4006	O4D4506	O4HD4506	O4D5006WC	O4HD5006WC		
7.0	33.9	O4D4007	O4D4507	O4HD4507	O4D5007WC	O4HD5007WC		
8.5	35.4	O4D4008	O4D4508	O4HD4508	O4D5008WC	O4HD5008WC		

Drilling Sequence **One485 Drill**

EKIII | ETIII | SSIII

Extra Short

Ø5.0 X 6mm

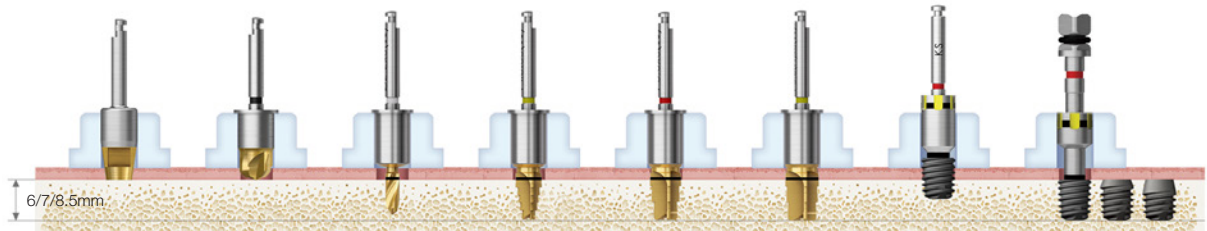

Ø5.0X6mm (Extra Short)	Bone Quality	Tissue Punch (W)	Flattening Drill (W)	Twist Drill (W)	Pilot Drill (W)	One485 Drill (W)	One485 Hard Drill (W)	NoMount Driver (W)	Implant Driver (W)
Ø5.0x 6/7/8.5mm	Normal	▶	(▶)	Ø2.2x6/7/8.5	Ø3.5x6	F5.0x6/7/8.5		Implant Placement (Up to 80%)	Implant Placement
	Hard	▶	(▶)	Ø2.2x6/7/8.5	Ø3.5x6		F5.0x6/7/8.5		

Drilling Sequence One485 Drill

EKIII | ETIII | SSIII

G/H 1.8 & 2.8

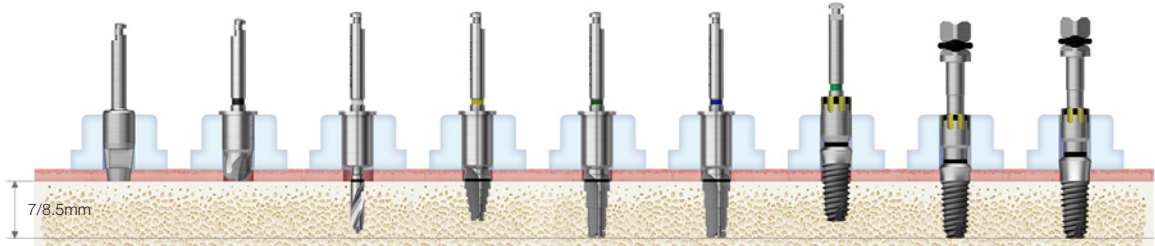

Implant	Bone Quality	Tissue Punch	Flattening Drill	Twist Drill	Pilot Drill	One485 Drill	One485 Drill	NoMount Driver	Implant Driver	
									G/H 1.8	G/H 2.8
Diameter 6/7/8.5mm	Normal	▶	(▶)	▶	▶	▶		Implant Placement (Up to 80%)	Implant Placement	
	Hard	▶	(▶)	▶	▶		▶		Implant Placement	

G/H 1.8&2.8

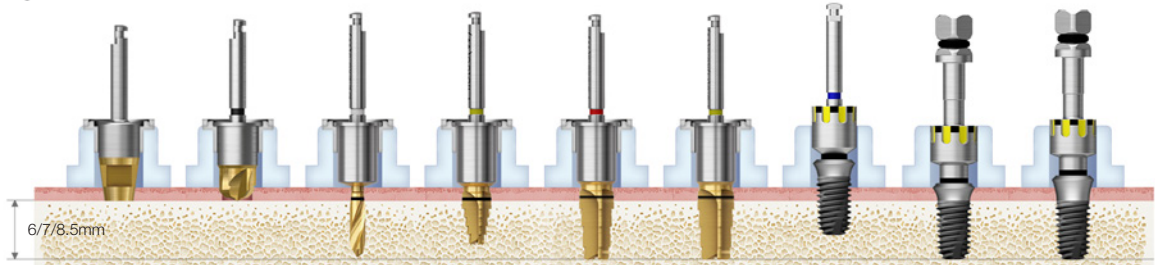

Implant	Bone Quality	Tissue Punch (W)	Flattening Drill (W)	Twist Drill (W)	Pilot Drill (W)	One485 Drill (W)	One485 Hard Drill (W)	NoMount Driver (W)	Implant Driver (W)	
									G/H 1.8	G/H 2.8
Diameter 6/7/8.5mm	Normal	▶	(▶)	▶	▶	▶		Implant Placement (Up to 80%)	Implant Placement	
	Hard	▶	(▶)	▶	▶		▶		Implant Placement	

122 Taper Kit (HK122TPK)

For

- EKIII
- ETIII/IV
- SSIII

Top panel components

Torque Wrench
TQWCB



Depth Gauge
ODG

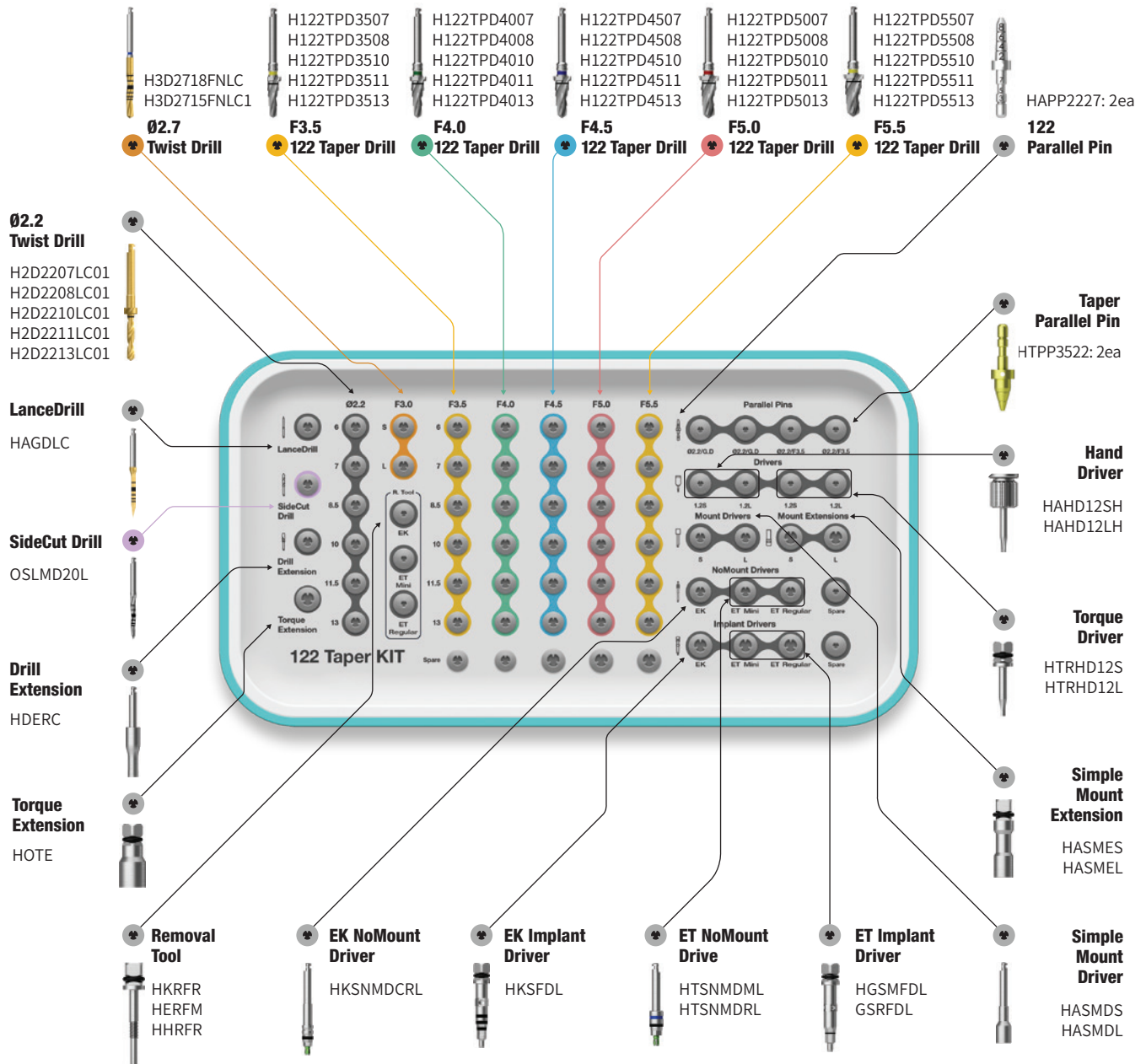

122 Taper Kit Surgical Kit Instruments

122 Taper Drill									
Description		Image/Guide							
<ul style="list-style-type: none"> Taper drill for Type III implants Specification by diameter and length Color coding displays implant diameter One step large-diameter drill is used to remove cortical bone from the hard bone 122 Taper Kit single item (excluded from Taper Kit) 									
L	TL	D/Ø Y-Dim.	F3.5 0.7	F4.0 0.9	F4.5 1.0	F5.0 1.0	F5.5 1.0	F6.0 1.0	F7.0 1.0
4.0	29.5		H122TPD3504	H122TPD4004	H122TPD4504	H122TPD5004	H122TPD5504	-	-
5.0	29.5		H122TPD3505	H122TPD4005	H122TPD4505	H122TPD5005	H122TPD5505	-	-
6.0	30.5		H122TPD3506	H122TPD4006	H122TPD4506	H122TPD5006	H122TPD5506	H122TPD6006	H122TPD7006
7.0	31.5		H122TPD3507	H122TPD4007	H122TPD4507	H122TPD5007	H122TPD5507	H122TPD6007	H122TPD7007
8.5	33		H122TPD3508	H122TPD4008	H122TPD4508	H122TPD5008	H122TPD5508	H122TPD6008	H122TPD7008
10	34.5		H122TPD3510	H122TPD4010	H122TPD4510	H122TPD5010	H122TPD5510	H122TPD6010	H122TPD7010
11.5	34.5		H122TPD3511	H122TPD4011	H122TPD4511	H122TPD5011	H122TPD5511	H122TPD6011	H122TPD7011
13	36		H122TPD3513	H122TPD4013	H122TPD4513	H122TPD5013	H122TPD5513	H122TPD6013	H122TPD7013
15	38		H122TPD3515	H122TPD4015	H122TPD4515	H122TPD5015	H122TPD5515	-	-
Color			Yellow	Green	Blue	Red	Yellow	Green	Blue

122 Taper Parallel Pin		
Description	Item Code	Image
<ul style="list-style-type: none"> Parallel pin for 122 Taper Drill Used for checking position and direction of bone preparation Lower part for 2.2 drill, upper part for guide drill 122 Taper Kit single item (excluded from Taper Kit) Other components same as Taper Kit 	HAPP2227	

Cortical Drill for Ultra-Wide			
Description	D/Ø	Item Code	Image
<ul style="list-style-type: none"> Drill is used to remove cortical bone from hard bone (for ultra-wide) Dedicated drill by implant diameter It is recommended to drill to the bottom line of the marking line 	F6.0	HCD4C60	
	F7.0	HCD4C70	

122 Taper Kit Surgical Kit Instruments

Implant Driver for EK				
Description	*C	Length	Item Code	Image
<ul style="list-style-type: none"> Connects directly to an EK implant for final adjustments to the implant's depth C = Connection 	Regular	Short	HKSFDS	
		Long	HKSFDL	

Implant Driver for ET				
Description	*C	Length	Item Code	Image
<ul style="list-style-type: none"> Connects directly to an ET implant for final adjustments to the implant's depth C = Connection 	Mini	Short (17)	HGSMFDS	
		Long (24)	GSMFDL	
		Ex. Long (34)	HGSMFDE	
	Regular	Short (19)	HGSRFDS	
		Long (26.6)	GSRFDL	
		Ex. Long (33.6)	HGSRFDE	

NoMount Driver for EK				
Description	*C	Length	Item Code	Image
<ul style="list-style-type: none"> Ø3.5 implant is combined with the bottom of the lower marking Ø4.0, Ø4.5, Ø5.0, Ø6.0 and Ø7.0 implants are combined with the upper part of the lower marking The distance between the two laser marking is 0.5mm C = Connection 	Regular	Short (27.6)	HKSNMDCRS	
		Long (32.6)	HKSNMDCRL	
		Extra Long (37.6)	HKSNMDCRE	

NoMount Torque Driver for ET				
Description	*C	Length	Item Code	Image
<ul style="list-style-type: none"> Directly connects to an ET Implant for placement with a Torque Wrench Ensure correct and complete seating before applying torque; loose connection may cause implant fracture C = Connection 	Mini	Short (19)	HGSNMT32S	
		Long (26.6)	HGSNMT32L	
		Ex. Long (33.6)	HGSNMT32E	
	Regular	Short (19)	HGSNMT35S	
		Long (26.6)	HGSNMT35L	
		Ex. Long (33.6)	HGSNMT35E	

122 Taper Kit Surgical Kit Instruments

LaceDrill (Guide Drill)			
Description	L	Item Code	Image
<ul style="list-style-type: none"> Forming a hole to facilitate initial drilling Bone density determined through drilling 	Long	HAGDLC	

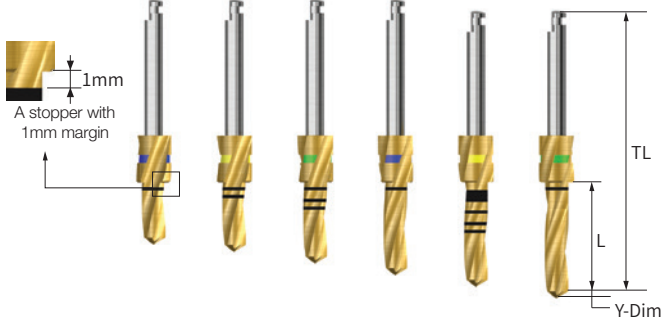
Twist Drill (Stopper Drill)										
Description			Image/Guide							
<ul style="list-style-type: none"> Included in New Hanaro KIT Long stopper (6mm) Enabling a procedure without drill extension for posterior region The color coded stopper indicates the drill length 										
L	TL	D/Ø Y-Dim.	F2.2 0.6	F3.0 0.9	F3.3 1.0	F3.6 1.0	F3.8 1.0	F4.1 1.0	F4.3 1.0	F4.3 1.0
6	30.5		2D2206LC	3D3006LC	-	-	3D3806LC	-	-	-
7	31.5		2D2207LC01	3D3007LC01	-	-	3D3807LC01	-	-	-
8.5	33		2D2208LC01	3D3008LC01	-	-	3D3808LC01	-	-	-
10	34.5		2D2210LC01	3D3010LC01	-	-	3D3810LC01	-	-	-
11.5	34.5		2D2211LC01	3D3011LC01	3D3311LC01	3D3611LC01	3D3811LC01	3D4111LC01	3D4311LC01	3D4611LC01
13	36		2D2213LC01	3D3013LC01	-	-	3D3813LC01	-	-	-

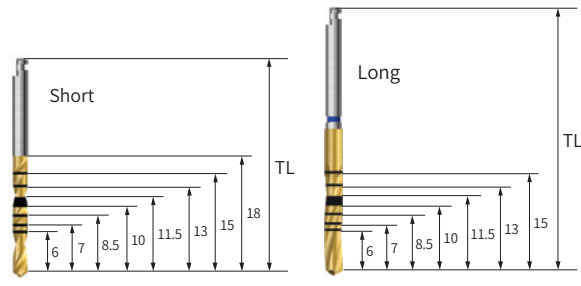
Twist Drill (Non Stopper Drill)							
Description			Image/Guide				
<ul style="list-style-type: none"> Included in New Hanaro KIT Used for limited access for the Stopper Drill into the oral cavity See the image provided in the Non-stopper Drill section for the sizes of the drill marking lines for short/long types 							
TL	D/Ø	F1.5	F2.0	F2.2	F2.7	F3.0	F3.3
33	Short	2D1518FNLC	2D2018FNLC	2D2218FNLC	3D2718FNLC	3D3018FNLC	3D3318FNLC
41		-	-	2D2215FNLC01	3D2715FNLC01	3D3015FNLC01	3D3315FNLC01
	D/Ø	F3.6	F3.8	F4.1	F4.3	F4.6	
33	Long	3D3618FNLC	3D3818FNLC	3D4118FNLC	3D4318FNLC	3D4618FNLC	
41		3D3615FNLC01	3D3815FNLC01	3D4115FNLC01	3D4315FNLC01	3D4615FNLC01	

Drilling Sequence 122 Taper Drill

EKIII | ETIII | SSIII

(Length: 10mm)

Ø3.2mm for ET
Ø3.3mm for EK

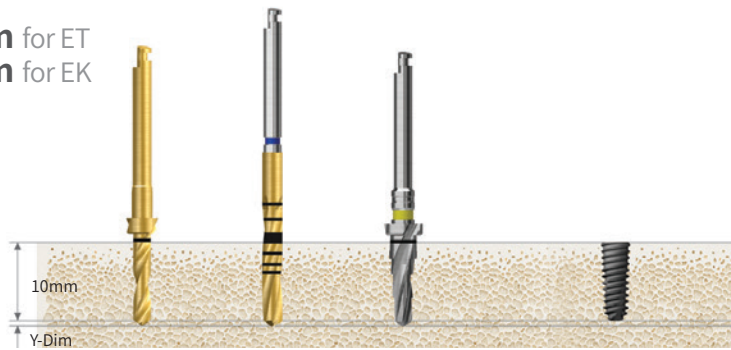

Bone Quality	Ø2.2 Drill	Ø2.7 Drill	F3.5 Taper Drill	Ø3.0 Implant
Soft	▶	▶		Implant Placement
Normal	▶	▶ or ▶		
Hard	▶		▶	

※ Lance drill can be used before Ø2.2 to mark the Osteotomy

※ The Ø2.7 Twist Drill is labeled as a 3.0mm drill in the kit case

Ø3.5mm

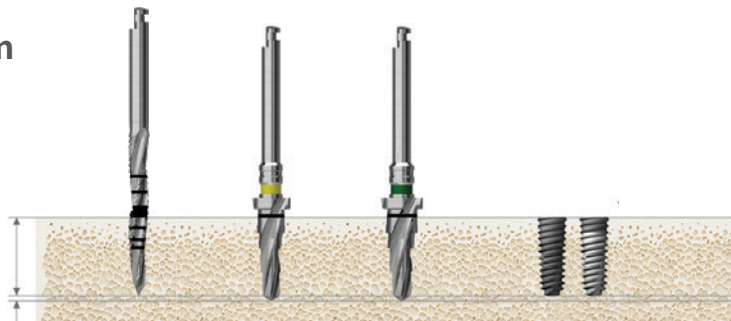

Bone Quality	Side Cut Drill	F3.5 Taper Drill	F4.0 Taper Drill	Ø3.5 Implant
Soft	▶			Implant Placement
Normal	▶	▶		
Hard	▶	▶	▶	

※ The recommended drill speed is 800–1,200 RPM, with an implant insertion torque of ≤40 Ncm.

※ The ET/EK implant is placed 1 mm subcrestally for normal and hard bone. However, in soft bone, the implant may be placed at bone level to ensure stability.

Ø4.0mm

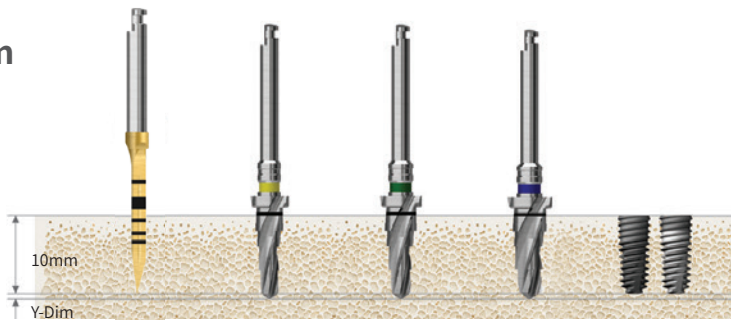

Bone Quality	Lance Drill	F3.5 Taper Drill	F4.0 Taper Drill	F4.5 Taper Drill	Ø4.0 Implant
Soft	▶	▶			Implant Placement
Normal	▶	▶	▶		
Hard	▶	▶		▶	

※ The recommended drill speed is 800–1,200 RPM, with an implant insertion torque of ≤40 Ncm.

※ The ET/EK implant is placed 1 mm subcrestally for normal and hard bone. However, in soft bone, the implant may be placed at bone level to ensure stability.

Ø4.5mm

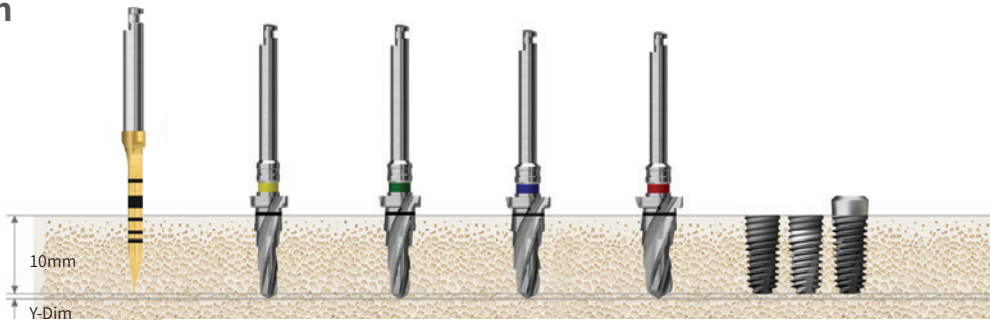

Bone Quality	Lance Drill	F3.5 Taper Drill	F4.0 Taper Drill	F4.5 Taper Drill	F5.0 Taper Drill	Ø4.5 Implant
Soft	▶		▶			Implant Placement
Normal	▶	▶		▶		
Hard	▶	▶			▶	

※ The recommended drill speed is 800–1,200 RPM, with an implant insertion torque of ≤ 40 Ncm.

※ The ET/EK implant is placed 1 mm subcrestally for normal and hard bone. However, in soft bone, the implant may be placed at bone level to ensure stability.

Ø5.0mm

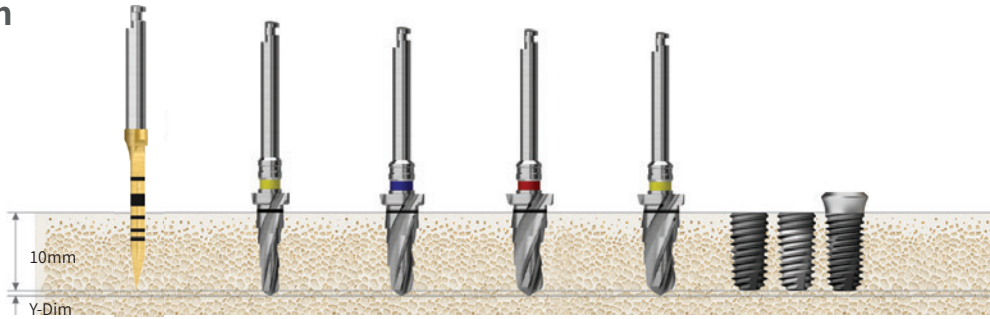

Bone Quality	Lance Drill	F3.5 Taper Drill	F4.5 Taper Drill	F5.0 Taper Drill	F5.5 Taper Drill	Ø5.0 Implant
Soft	▶		▶			Implant Placement
Normal	▶	▶		▶		
Hard	▶	▶			▶	

※ The recommended drill speed is 800–1,200 RPM, with an implant insertion torque of ≤ 40 Ncm.

※ The ET/EK implant is placed 1 mm subcrestally for normal and hard bone. However, in soft bone, the implant may be placed at bone level to ensure stability.

Drilling Sequence 122 Taper Drill

ETIV

(Length: 10mm)

Ø4.0mm

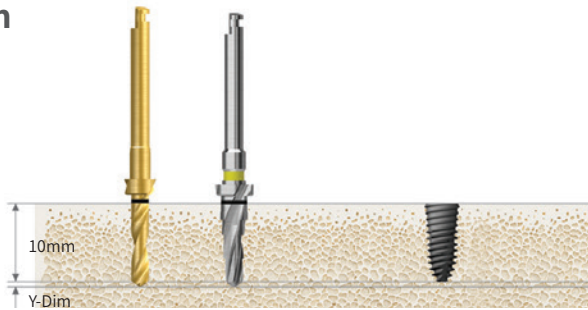

Bone Quality	Ø2.2 Drill	F3.5 Taper Drill	Ø4.0 Implant
D4	▶		Implant Placement
Soft	▶	▶	

※ The recommended drill speed is 800–1,200 RPM, with an implant insertion torque of ≤40 Ncm.

※ The ET/EK implant is placed 1 mm subcrestally for normal and hard bone. However, soft bone may be placed at the bone level to ensure stability.

Ø4.5mm

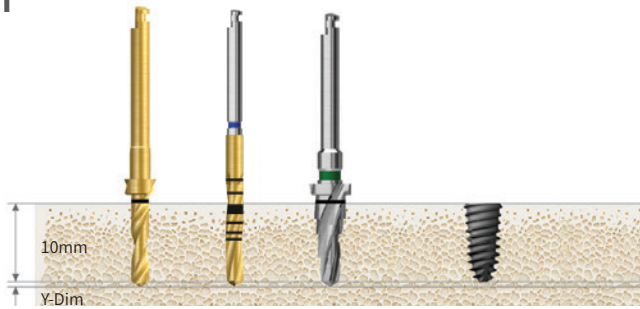

Bone Quality	Ø2.2 Drill	Ø3.0 Drill	F4.0 Taper Drill	Ø4.5 Implant
D4		▶		Implant Placement
Soft	▶		▶	

※ The recommended drill speed is 800–1,200 RPM, with an implant insertion torque of ≤40 Ncm.

※ The ET/EK implant is placed 1 mm subcrestally for normal and hard bone. However, soft bone may be placed at the bone level to ensure stability.

Ø5.0mm

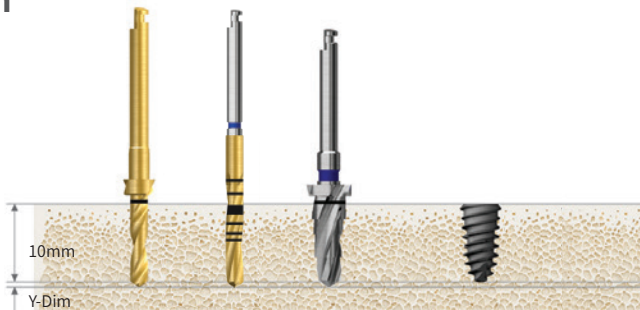

Bone Quality	Ø2.2 Drill	Ø3.0 Drill	F4.5 Taper Drill	Ø5.0 Implant
D4		▶		Implant Placement
Soft	▶		▶	

※ The recommended drill speed is 800–1,200 RPM, with an implant insertion torque of ≤40 Ncm.

※ The ET/EK implant is placed 1 mm subcrestally for normal and hard bone. However, soft bone may be placed at the bone level to ensure stability.

HIOSSEN
IMPLANT

Taper Kit (HKTAPEK)

For

EKIII

ETIII/IV

SSIII

Top panel components

Torque Wrench
TQWCB



Depth Gauge
ODG

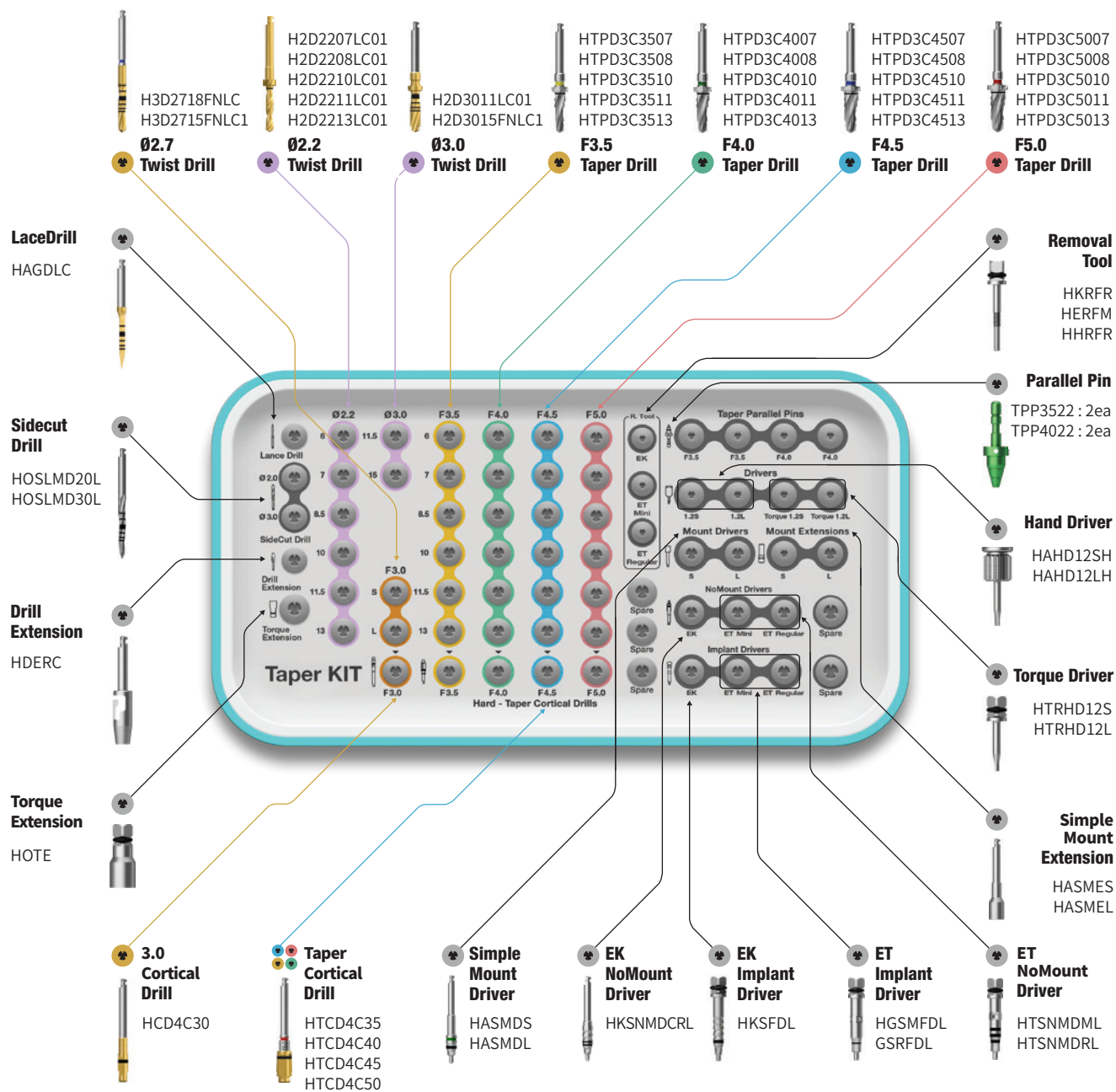

Taper Ultra Kit (HULTPK)

For **Ultra-wide**

Top panel components

Open Wrench
SPOW



Ratchet Wrench
RCWC

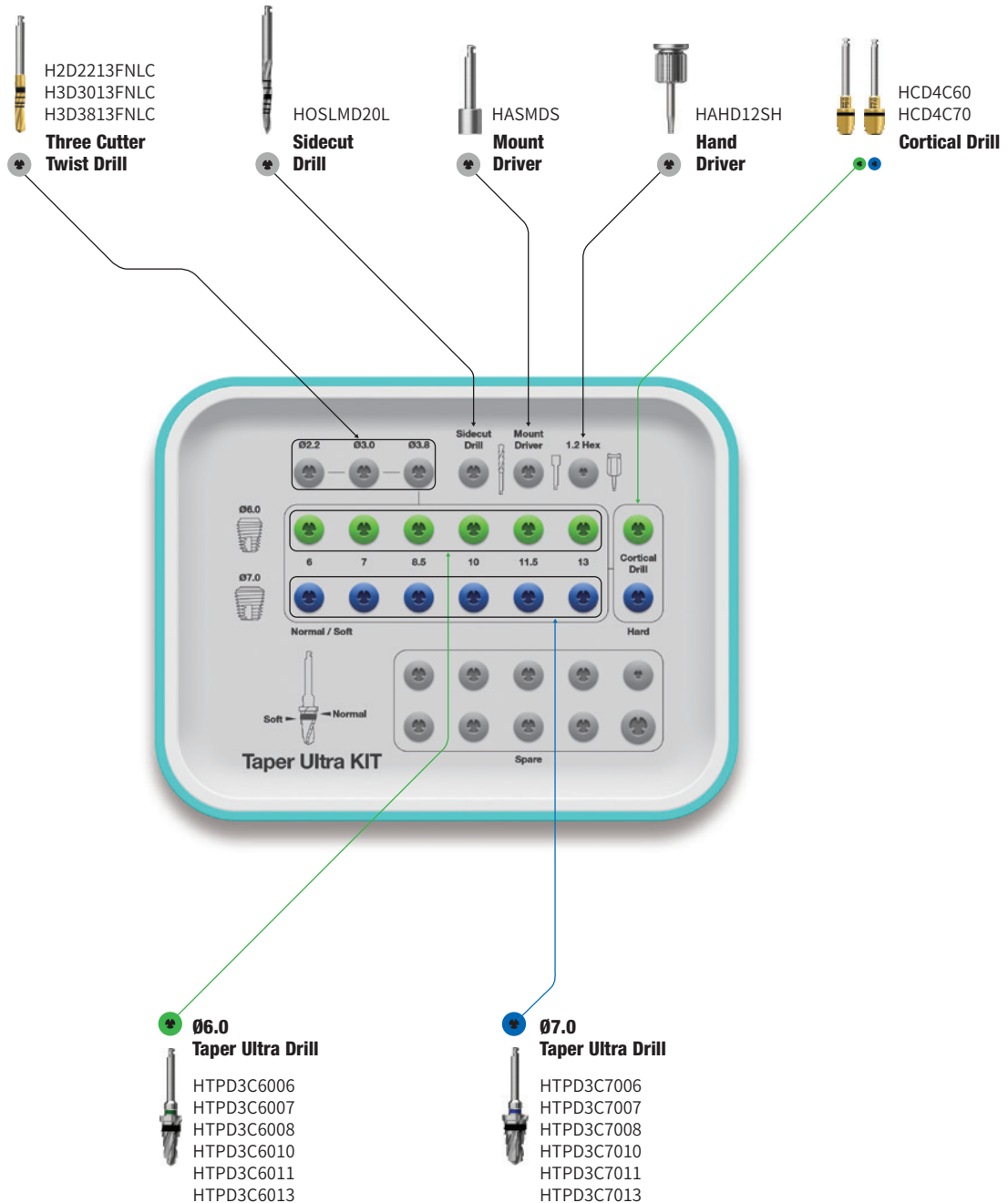

Taper Kit Surgical Kit Instruments

Parallel Pin for Taper Drill			
Description	D/Ø	Item code	Image
<ul style="list-style-type: none"> Parallel pin for taper drill Used for checking position and direction of bone preparation The lower part is for implant diameter drill and the upper part is for initial drill Color coding by implant diameter (F3.5: yellow, F4.0: green, F4.5: blue, F5.0: silver) 122 Taper & Taper Kit common components 	F3.5	HTPP3522	
	F4.0	HTPP4022	
	F4.5	HTPP4522	
	F5.0	HTPP5022	

Taper Drill		Image/Guide					
Description		Image/Guide					
<ul style="list-style-type: none"> Taper drill for taper(III type) implant by diameter and length Stopper drill with 1mm space Color coding displays implant diameter F3.5: yellow, F4.0: green, F4.5: blue, F5.0: red, F5.5: yellow Taper Kit single item (*excluded from 122 Taper Kit) 							
L	TL	D/Ø Y-Dim.	F3.5	F4.0	F4.5	F5.0	F5.5
			0.8	0.9	1.0	1.0	1.0
5.0	29.5		HTPD3C3505	HTPD3C4005	HTPD3C4505	HTPD3C5005	-
6.0	30.5		HTPD3C3506	HTPD3C4006	HTPD3C4506	HTPD3C5006	HTPD3C5506
7.0	31.5		HTPD3C3507	HTPD3C4007	HTPD3C4507	HTPD3C5007	HTPD3C5507
8.5	33		HTPD3C3508	HTPD3C4008	HTPD3C4508	HTPD3C5008	HTPD3C5508
10	34.5		HTPD3C3510	HTPD3C4010	HTPD3C4510	HTPD3C5010	HTPD3C5510
11.5	34.5		HTPD3C3511	HTPD3C4011	HTPD3C4511	HTPD3C5011	HTPD3C5511
13	36		HTPD3C3513	HTPD3C4013	HTPD3C4513	HTPD3C5013	HTPD3C5513
15	38		HTPD3C3515	HTPD3C4015	HTPD3C4515	HTPD3C5015	HTPD3C5515
Color			Yellow	Green	Blue	Red	Yellow

LaceDrill (Guide Drill)			
Description	L	Item Code	Image
<ul style="list-style-type: none"> Forming a hole to facilitate initial drilling Bone density determined through drilling 	Long	HAGDLC	

Taper Kit Surgical Kit Instruments

Slidecut Drill		
Description	Item Code	Image
<ul style="list-style-type: none"> Forming a hole to facilitate initial drilling Bone density determined through drilling 	HOSLMD20L	

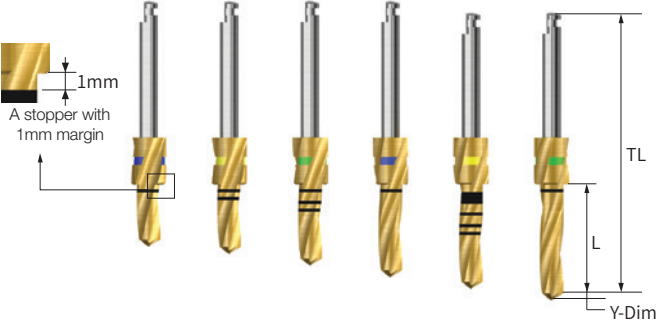
Twist Drill (Stopper Drill)										
Description			Image/Guide							
<ul style="list-style-type: none"> Included in New Hanaro KIT Long stopper (6mm) Enabling a procedure without drill extension for posterior region The color coded stopper indicates the drill length 										
L	TL	D/Ø Y-Dim.	F2.2 0.6	F3.0 0.9	F3.3 1.0	F3.6 1.0	F3.8 1.0	F4.1 1.0	F4.3 1.0	F4.3 1.0
6	30.5		2D2206LC	3D3006LC	-	-	3D3806LC	-	-	-
7	31.5		2D2207LC01	3D3007LC01	-	-	3D3807LC01	-	-	-
8.5	33		2D2208LC01	3D3008LC01	-	-	3D3808LC01	-	-	-
10	34.5		2D2210LC01	3D3010LC01	-	-	3D3810LC01	-	-	-
11.5	34.5		2D2211LC01	3D3011LC01	3D3311LC01	3D3611LC01	3D3811LC01	3D4111LC01	3D4311LC01	3D4611LC01
13	36		2D2213LC01	3D3013LC01	-	-	3D3813LC01	-	-	-

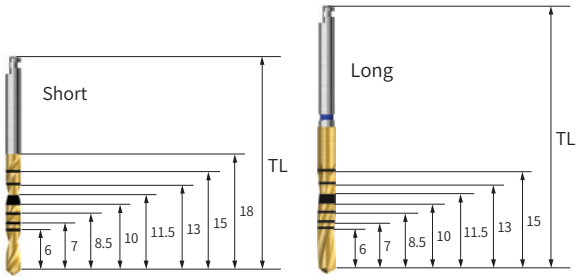
Twist Drill (Non Stopper Drill)							
Description			Image/Guide				
<ul style="list-style-type: none"> Included in New Hanaro KIT Used for limited access for the Stopper Drill into the oral cavity See the image provided in the Non-stopper Drill section for the sizes of the drill marking lines for short/long types 							
TL	D/Ø	F1.5	F2.0	F2.2	F2.7	F3.0	F3.3
33	Short	2D1518FNLC	2D2018FNLC	2D2218FNLC	3D2718FNLC	3D3018FNLC	3D3318FNLC
41		-	-	2D2215FNLC01	3D2715FNLC01	3D3015FNLC01	3D3315FNLC01
	D/Ø	F3.6	F3.8	F4.1	F4.3	F4.6	
33	Long	3D3618FNLC	3D3818FNLC	3D4118FNLC	3D4318FNLC	3D4618FNLC	
41		3D3615FNLC01	3D3815FNLC01	3D4115FNLC01	3D4315FNLC01	3D4615FNLC01	



Taper Cortical Drill for Taper Implant (ETIII, SSIII)			
Description	D/Ø	Item code	Image
<ul style="list-style-type: none"> The drill is used to remove cortical bone of the hard bone (used right after the use of Taper Drill) Dedicated drill for each implant diameter F3.5~5.0 drill marking line: bottom line 8.5mm or less, top line 10mm or more implant placement standard F5.5 drill marking line: bottom line 6mm or less, middle line 7mm, top line 8.5mm or more implant placement standard It is recommended to drill to the bottom of the marking line Taper Kit single item (excluded from 122 Taper Kit) 	F3.5	HTCD4C35	
	F4.0	HTCD4C40	
	F4.5	HTCD4C45	
	F5.0	HTCD4C50	
	F5.5	HTCD4C55	

Taper Ultra Drill				
Description	L	F6.0	F7.0	Image
<ul style="list-style-type: none"> Taper drill for taper ultra-wide implant by diameter and length Stopper drill with 1mm space Color coding displays implant diameter 	6.0	HTPD3C6006	HTPD3C7006	
	7.0	HTPD3C6007	HTPD3C7007	
	8.5	HTPD3C6008	HTPD3C7008	
	10	HTPD3C6010	HTPD3C7010	
	11.5	HTPD3C6011	HTPD3C7011	
	13	HTPD3C6013	HTPD3C7013	
	Color	Green	Blue	







Implant Driver for EK				
Description	C	Length	Item Code	Image
<ul style="list-style-type: none"> Connects directly to an EK implant for final adjustments to the implant's depth C = Connection 	Regular	Short	HKSFDS	
		Long	HKSFDL	

Implant Driver for ET				
Description	C	Length	Item Code	Image
<ul style="list-style-type: none"> Connects directly to an ET implant for final adjustments to the implant's depth C = Connection 	Mini	Short (17)	HGSMFDS	
		Long (24)	GSMFDL	
		Ex. Long (34)	HGSMFDE	
	Regular	Short (19)	HGSRFDS	
		Long (26.6)	GSRFDL	
		Ex. Long (33.6)	HGSRFDE	

Taper Kit Surgical Kit Instruments

NoMount Driver for EK				
Description	C	Length	Item Code	Image
<ul style="list-style-type: none"> • Ø3.5 implant is combined with the bottom of the lower marking • Ø4.0, Ø4.5, Ø5.0, Ø6.0 and Ø7.0 implants are combined with the upper part of the lower marking • The distance between the two laser marking is 0.5mm • C = Connection 	Regular	Short (27.6)	HKSNMDCRS	
		Long (32.6)	HKSNMDCRL	
		Extra Long (37.6)	HKSNMDCRE	

Ø4.0, Ø4.5, Ø5.0, Ø6.0, Ø7.0 Ø3.0, 3.5
 Implant Implant

NoMount Torque Driver for ET				
Description	C	Length	Item Code	Image
<ul style="list-style-type: none"> • Directly connects to an ET Implant for placement with a Torque Wrench • Ensure correct and complete seating before applying torque; loose connection may cause implant fracture • C = Connection 	Mini	Short (19)	HGSNMT32S	
		Long (26.6)	HGSNMT32L	
		Ex. Long (33.6)	HGSNMT32E	
	Regular	Short (19)	HGSNMT35S	
		Long (26.6)	HGSNMT35L	
		Ex. Long (33.6)	HGSNMT35E	

Drilling Sequence Taper Drill

EKIII | ETIII | SSIII

(Length: 10mm)

Ø3.2mm

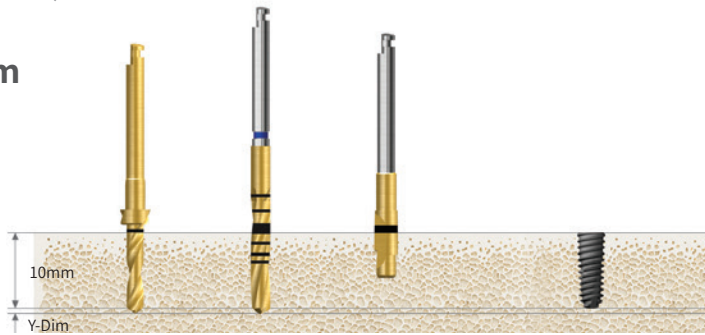

Bone Quality	Ø2.2 Drill	Ø2.7 Drill	F3.0 Cortical Drill	Ø3.0 Implant
Soft	▶			
Normal	▶	▶		Implant Placement
Hard	▶	▶	▶	

Ø3.5mm

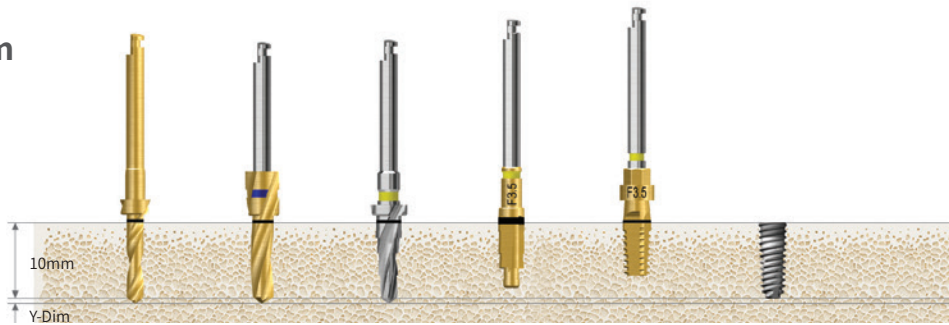

Bone Quality	Ø2.2 Drill	Ø3.0 Drill	F3.5 Taper Drill	F3.5 Taper Cortical Drill	F3.5 Taper Implant Tap	Ø3.5 Implant
Soft	▶	▶				
Normal	▶			▶		Implant Placement
Hard	▶		▶	▶		
Hard (Option)	▶		▶		▶	

Ø4.0mm

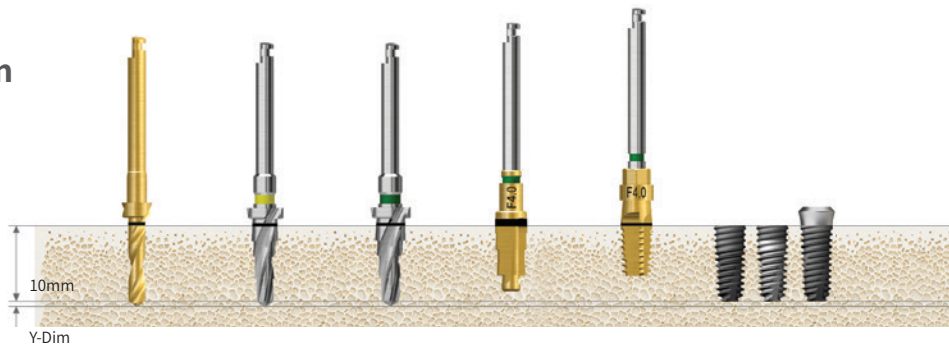

Bone Quality	Ø2.2 Drill	F3.5 Taper Drill	F4.0 Taper Drill	F4.0 Taper Cortical Drill	F4.0 Taper Implant Tap	Ø4.0 Implant
Soft	▶	▶				
Normal	▶	▶	▶			Implant Placement
Hard	▶	▶	▶	▶		
Hard (Option)	▶	▶	▶		▶	

Ø4.5mm

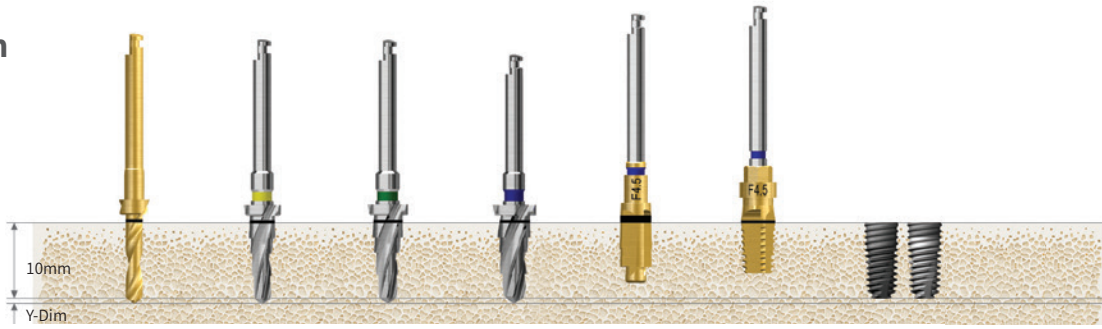

Bone Quality	Ø2.2 Drill	F3.5 Taper Drill	F4.0 Taper Drill	F4.5 Taper Drill	F4.5 Taper Cortical Drill	F4.5 Taper Implant Tap	Ø4.5 Implant
Soft	▶	▶	▶				Implant Placement
Normal	▶	▶		▶			
Hard	▶	▶		▶	▶		
Hard (Option)	▶	▶		▶		▶	

Ø5.0mm

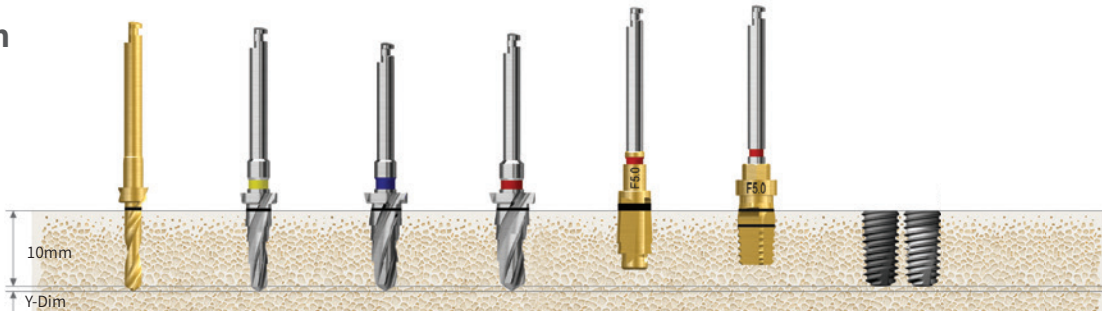

Bone Quality	Ø2.2 Drill	F3.5 Taper Drill	F4.5 Taper Drill	F5.0 Taper Drill	F5.0 Taper Cortical Drill	F5.0 Taper Implant Tap	Ø5.0 Implant
Soft	▶	▶	▶				Implant Placement
Normal	▶	▶	▶	▶			
Hard	▶	▶	▶	▶	▶		
Hard (Option)	▶	▶	▶	▶		▶	

Ø5.5mm

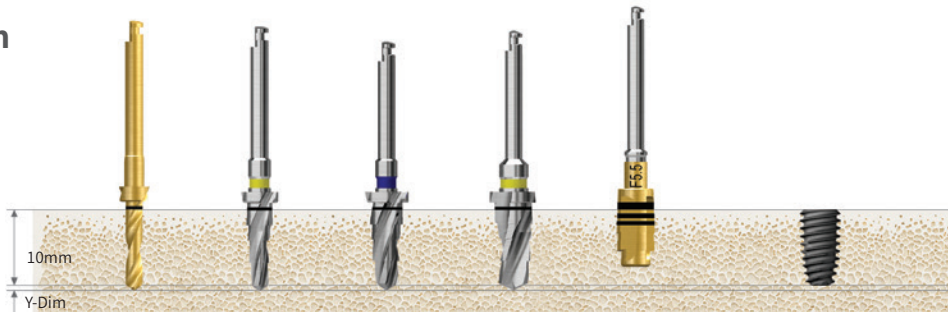

Bone Quality	Ø2.2 Drill	F3.5 Taper Drill	F4.5 Taper Drill	F5.5 Taper Drill	F5.5 Taper Implant Tap	Ø5.5 Implant
Soft	▶	▶	▶			Implant Placement
Normal	▶	▶	▶	▶		
Hard	▶	▶	▶	▶	▶	

F5.5 taper cortical drill marking line: bottom line 6mm or less, middle line 7mm, top line 8.5mm or more

Recommended insertion torque ≤40Ncm. ET implant insertion depth in normal/hard bone is placed 1mm deeper than the bone level, and the soft bone is placed at the bone level to maintain initial stability.

Implant tap used in hard bone: 25rpm recommended with engine or use with torque wrench after fastening to mount extension (F5.0 implant tap: bottom line 7mm or less, top line 8.5mm or more).

Drilling Sequence Taper Drill

ETIV

(Length: 10mm)

Ø4.0mm

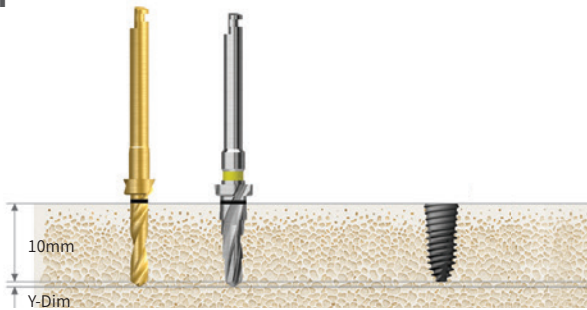

Bone Quality	Ø2.2 Drill	F3.5 Taper Drill	Ø4.0 Implant
D4	▶		Implant Placement
Soft	▶	▶	

Ø4.5mm

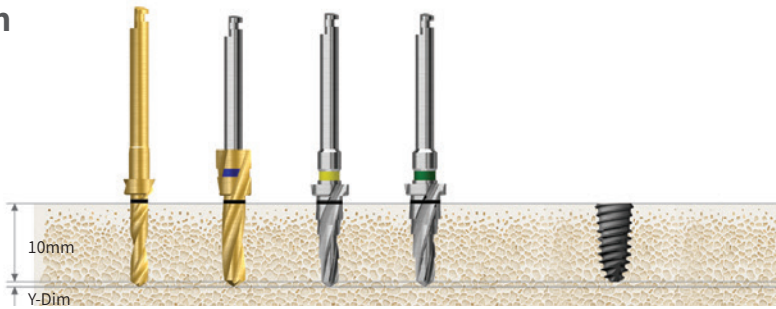

Bone Quality	Ø2.2 Drill	Ø3.0 Drill	F3.5 Taper Drill	F4.0 Taper Drill	Ø4.5 Implant
D4		▶			Implant Placement
Soft	▶		▶	▶	

Ø5.0mm

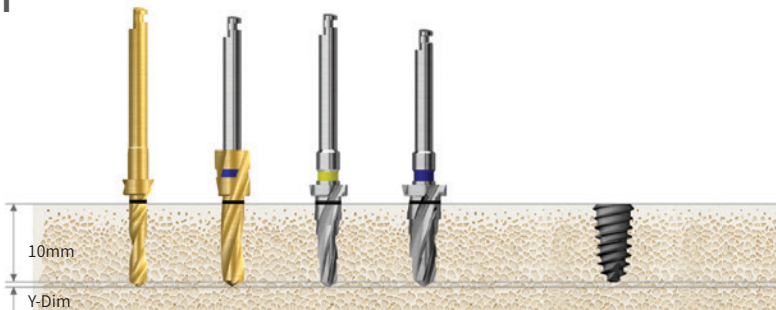

Bone Quality	Ø2.2 Drill	Ø3.0 Drill	F3.5 Taper Drill	F4.5 Taper Drill	Ø5.0 Implant
D4		▶			Implant Placement
Soft	▶		▶	▶	

Drilling Sequence Taper Drill

ETIII Ultra-wide

(Length: 10mm)

Ø6.0mm

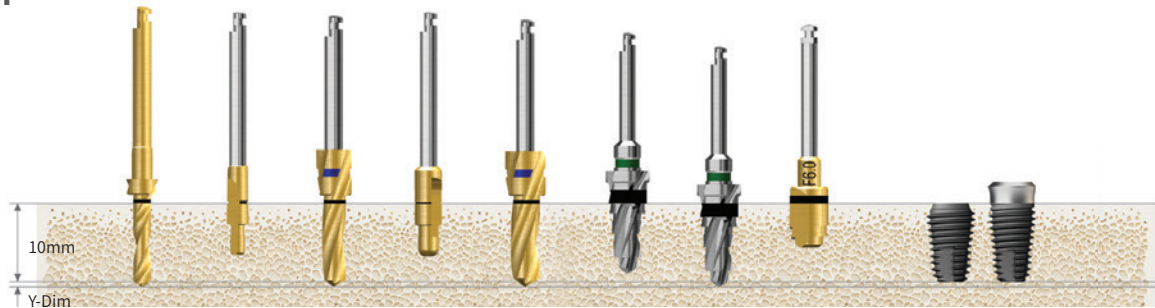

Bone Quality	Ø2.2 Drill	Ø2.0/3.0 Pilot Drill	Ø3.0 Drill	Ø3.0/3.8 Pilot Drill	Ø3.8 Drill	F6.0 Taper Drill	F6.0 Taper Drill	F6.0 Cortical Drill	Ø6.0 Implant
Soft	▶	▶	▶	▶		▶			Implant Placement
Normal	▶	▶	▶	▶	▶		▶		
Hard	▶	▶	▶	▶	▶		▶	▶	

Ø7.0mm

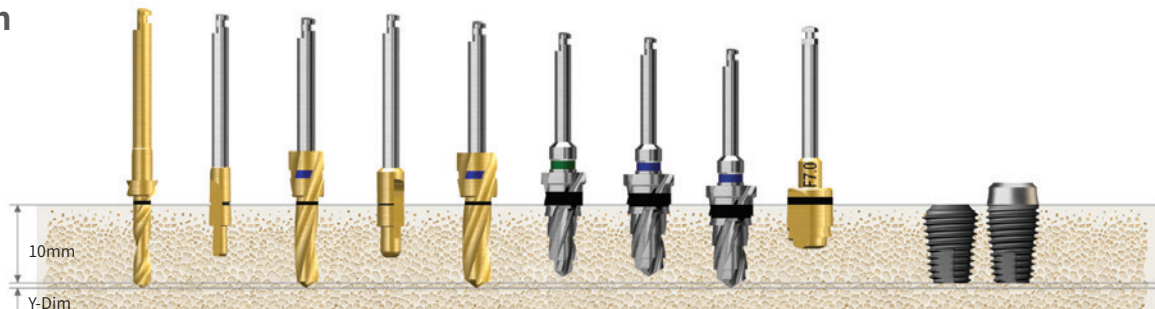

Bone Quality	Ø2.2 Drill	Ø2.0/3.0 Pilot Drill	Ø3.0 Drill	Ø3.0/3.8 Pilot Drill	Ø3.8 Drill	F6.0 Taper Drill	F7.0 Taper Drill	F7.0 Taper Drill	F7.0 Cortical Drill	Ø7.0 Implant
Soft	▶	▶	▶	▶		▶	▶			Implant Placement
Normal	▶	▶	▶	▶	▶	▶		▶		
Hard	▶	▶	▶	▶	▶	▶		▶	▶	

Recommended placement torque less than 40Ncm.

ET implant placement depth. The normal/hard bone is placed 1mm deeper than bone level, and the soft bone is placed at the bone level to maintain initial stability.

Drilling Sequence Taper Drill

ETIV Ultra-wide

(Length: 10mm)

Ø6.0mm

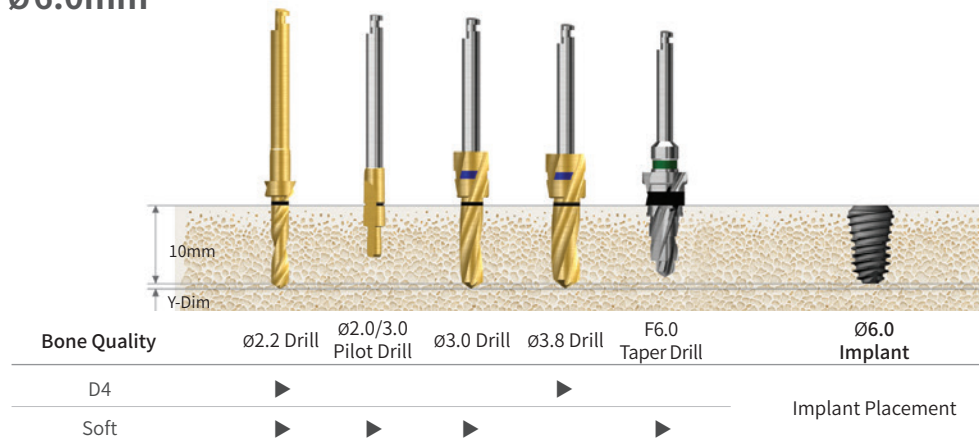

Ø7.0mm

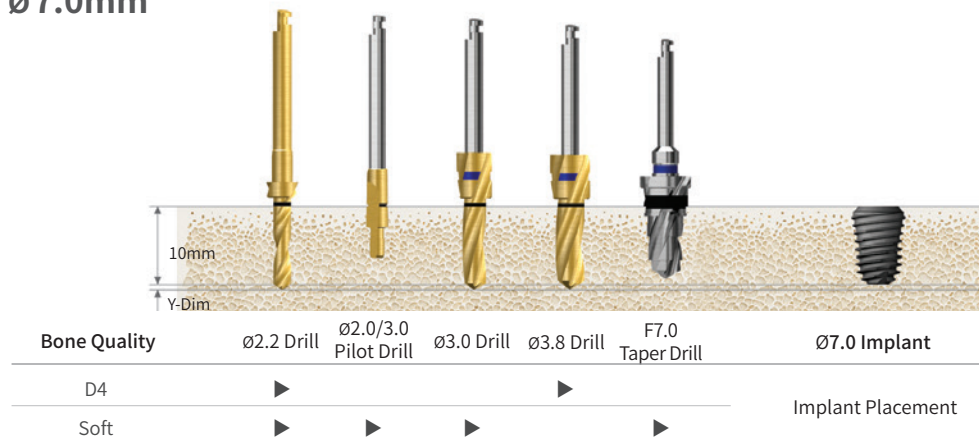

Recommended placement torque less than 40Ncm.

ET implant placement depth. The normal/hard bone is placed 1mm deeper than bone level, and the soft bone is placed at the bone level to maintain initial stability.

HIOSSEN
IMPLANT

485 Kit (H485K)

For

- EKIII
- ETIII/IV
- SSII/III
- Ultra-Wide

Top panel components

Torque Wrench

TQWCB



Depth Gauge

ODG

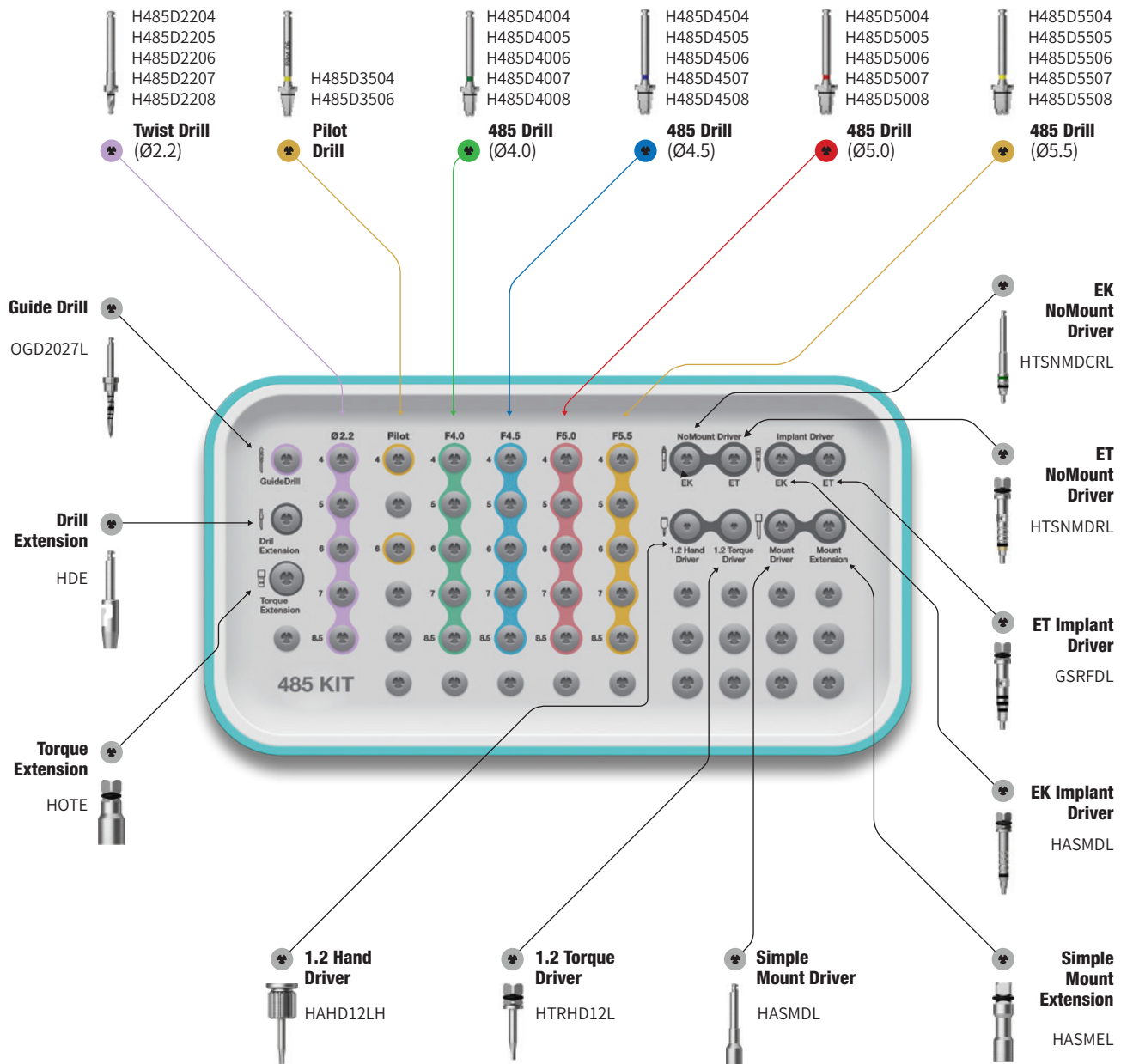

485 Kit Surgical Kit Instruments

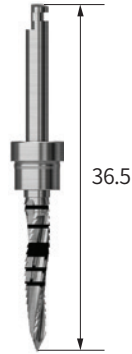
Guide Drill		
Description	Ø2.2	Image
<ul style="list-style-type: none"> Drill for marking location of osteotomy to facilitate initial drilling 	OGD2027L	

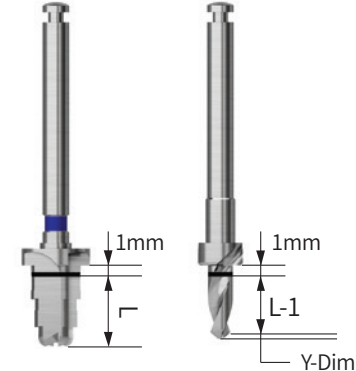
485 Drill						
Description	Image/Guide					
<ul style="list-style-type: none"> Included in 485 Kit A drill for placing short implants in alveolar bone lacking in vertical dimension Ø 2.2 drill: straight drill Except for Ø 2.2 drill, the top blade of the drill is in the shape of CAS Drill, and the side blade is in the shape of taper drill A stopper drill with 1mm margin Recommended drilling speed: 800~1,200rpm 						
L	Ø2.2	Pilot	F4.0	F4.5	F5.0	F5.5
4.0	H485D2204	H485D3504	H485D4004	H485D4504	H485D5004	H485D5504
5.0	H485D2205	-	H485D4005	H485D4505	H485D5005	H485D5505
6.0	H485D2206	H485D3506	H485D4006	H485D4506	H485D5006	H485D5506
7.0	H485D2207	-	H485D4007	H485D4507	H485D5007	H485D5507
8.5	H485D2208	-	H485D4008	H485D4508	H485D5008	H485D5508

485 Kit Surgical Kit Instruments

Implant Driver for EK				
Description	C	Length	Item Code	Image
<ul style="list-style-type: none"> Connects directly to an EK implant for final adjustments to the implant's depth C = Connection 	Regular	Short	HKSFDS	
		Long	HKSFDL	

Implant Driver for ET				
Description	C	Length	Item Code	Image
<ul style="list-style-type: none"> Connects directly to an ET implant for final adjustments to the implant's depth C = Connection 	Mini	Short (17)	HGSMFDS	
		Long (24)	GSMFDL	
		Ex. Long (34)	HGSMFDE	
	Regular	Short (19)	HGSRFDS	
		Long (26.6)	GSRFDL	
		Ex. Long (33.6)	HGSRFDE	

NoMount Driver for EK				
Description	C	Length	Item Code	Image
<ul style="list-style-type: none"> Ø3.5 implant is combined with the bottom of the lower marking Ø4.0, Ø4.5, Ø5.0, Ø6.0 and Ø7.0 implants are combined with the upper part of the lower marking The distance between the two laser marking is 0.5mm C = Connection 	Regular	Short (27.6)	HKSNMDCRS	
		Long (32.6)	HKSNMDCRL	
		Extra Long (37.6)	HKSNMDCRE	

NoMount Torque Driver for ET				
Description	C	Length	Item Code	Image
<ul style="list-style-type: none"> Directly connects to an ET Implant for placement with a Torque Wrench Ensure correct and complete seating before applying torque; loose connection may cause implant fracture C = Connection 	Mini	Short (19)	HGSNMT32S	
		Long (26.6)	HGSNMT32L	
		Ex. Long (33.6)	HGSNMT32E	
	Regular	Short (19)	HGSNMT35S	
		Long (26.6)	HGSNMT35L	
		Ex. Long (33.6)	HGSNMT35E	

Drilling Sequence 485 Drill

EKIII | ETIII/IV | SSII/III | ULTRA-WIDE

(Length: 7mm)

Ø4.0mm

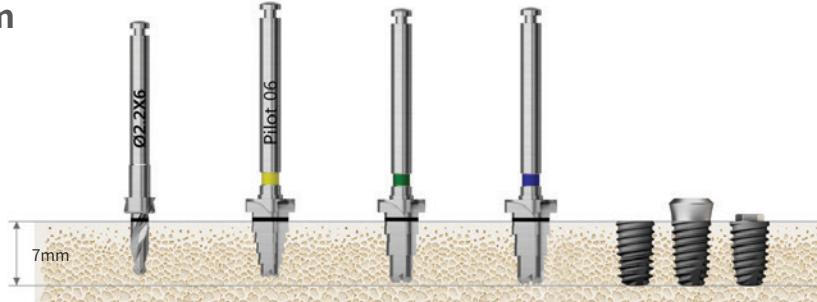

Bone Quality	Twist Drill (Ø2.2)	Pilot Drill	485 Drill (F4.0)	485 Drill (F4.5)	Ø4.0 Implant
Normal	▶	▶	▶		Implant Placement
Hard	▶	▶		▶	

Ø4.5mm

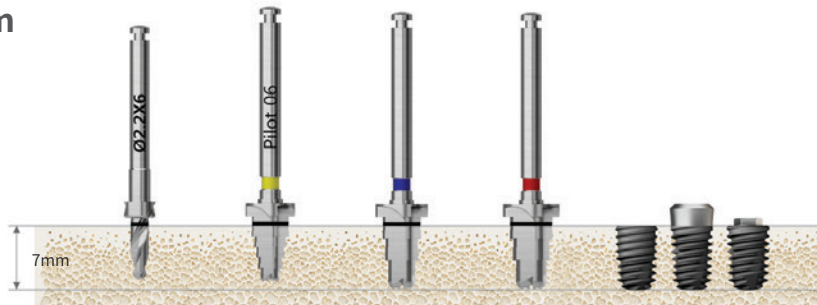

Bone Quality	Twist Drill (Ø2.2)	Pilot Drill	485 Drill (F4.5)	485 Drill (F5.0)	Ø4.5 Implant
Normal	▶	▶	▶		Implant Placement
Hard	▶	▶		▶	

Ø5.0mm

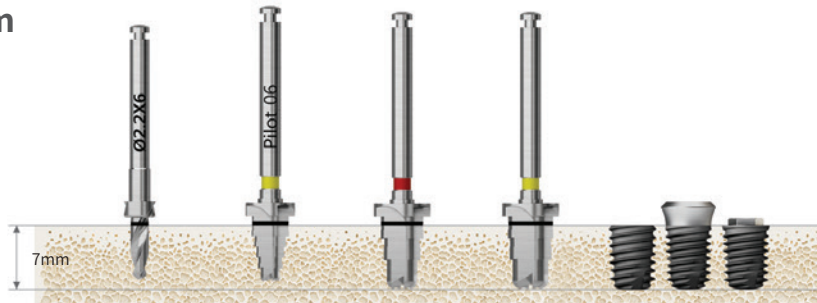

Bone Quality	Twist Drill (Ø2.2)	Pilot Drill	485 Drill (F5.0)	485 Drill (F5.5)	Ø5.0 Implant
Normal	▶	▶	▶		Implant Placement
Hard	▶	▶		▶	

Assist Kit (HOAK)

• Bone profilers are only sold in the packing unit of “Guide Screw + Bone Profiler”

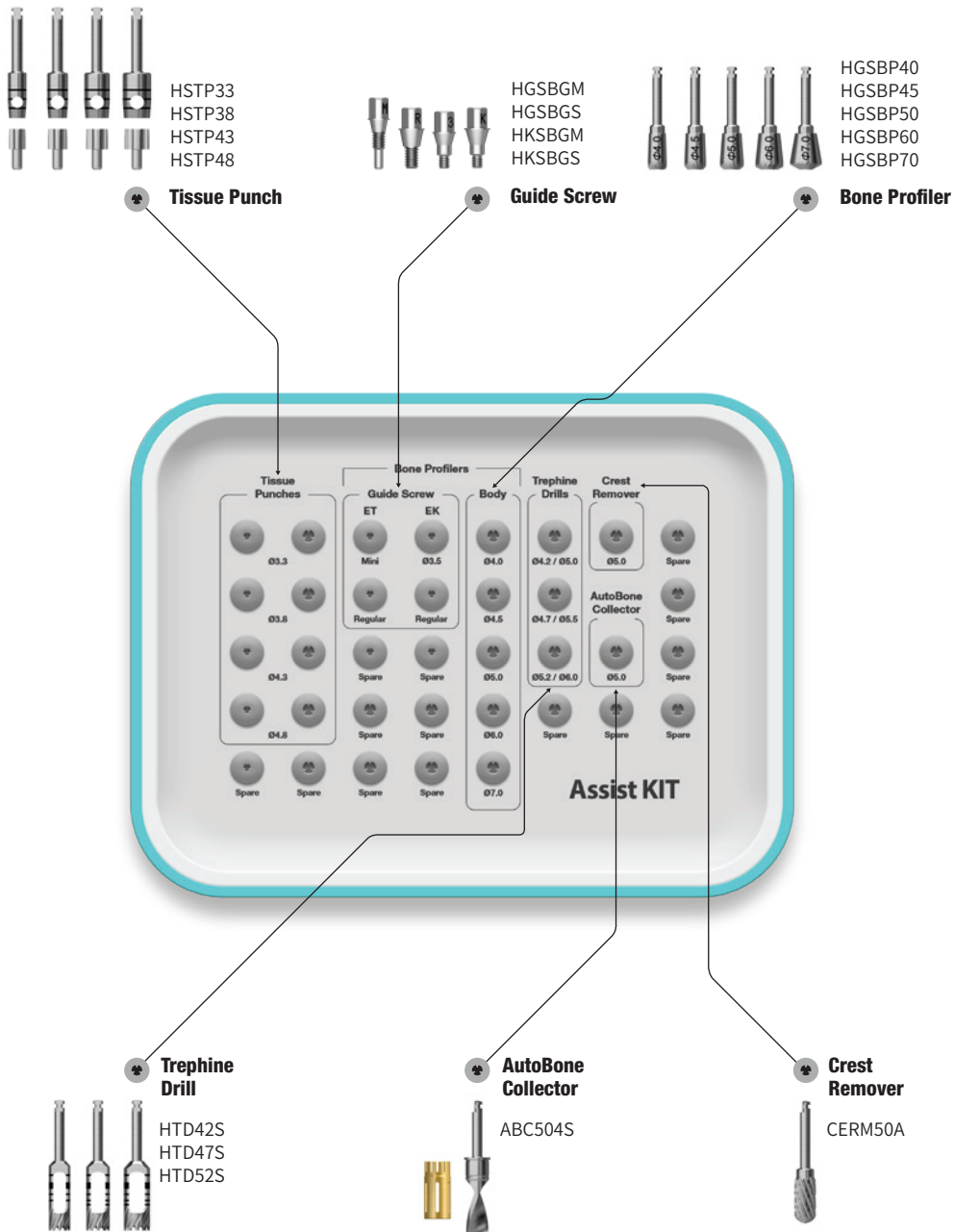

Assist Kit Surgical Instrument

Tissue Punch					
Description/Item code		Image/Guide			
<ul style="list-style-type: none"> For flapless surgery Laser marking to measure the height of gingiva, marked in 2mm increments Packing unit: tissue punch + guide pin Recommend to use a tissue punch smaller than the healing abutment by 0.7 to 1.5mm 					
ET	SS			D/Ø	Item Code
Ø 4.0/4.5	-			Ø3.3	HSTP33
Ø 4.5/5.0	Ø 4.8			Ø3.8	HSTP38
Ø 5.0	-			Ø4.3	HSTP43
Ø 6.0	Ø 6.0			Ø4.8	HSTP48
Ø 6.0	Ø 6.0	Ø5.3	HSTP53		
Application healing abutment standard					

Bone Profiler			
Description/Item code		Image/Guide	
<ul style="list-style-type: none"> Used to remove bone around the implant after first or second stage surgery Connect the Guide Screw to the implant in order to center the profiler Guide screw protects the implant's platform from damage Packing unit: bone profiler + guide screw C = Connection 			
D (Healing Abutment)	ET		EK
Ø4.0	HGSBP40 Mini + Regular guide screw		HKSBP40 3.3/3.5 + Regular guide screw
Ø4.5	HGSBP45 Mini + Regular guide screw		HKSBP45 3.3/3.5 + Regular guide screw
Ø5.0	HGSBP50 Regular guide screw		HKSBP50 Regular guide screw
Ø6.0	HGSBP60 Regular guide screw		HKSBP60 Regular guide screw
Ø7.0	HGSBP70 Regular guide screw	HKSBP70 Regular guide screw	
Guide Screw			
	HGSBGM Mini	HKSBGM 3.3/3.5	
	HGSBGS Regular	HKSBGS Regular	

Trepine Drill		
Description/Item code		Image/Guide
<ul style="list-style-type: none"> Harvests bone or removes a failed implant Used to remove septal bone Can also be used as the initial drill for ultra-wide implants 		
D/Ø (Inner/Outer)	Short	
3.7/4.5	HTD37S	HTD37
4.2/5.0	HTD42S	HTD42
4.7/5.5	HTD47S	HTD47
5.2/6.0	HTD52S	HTD52
5.7/6.5	HTD57S	HTD57
6.2/7.0	HTD62S	HTD62

Crest Remover		
Description/Item code		Image/Guide
<ul style="list-style-type: none"> Marking the implant placement position after removing the narrow alveolar ridge horizontally Recommended drilling speed <ul style="list-style-type: none"> - Angled type: 1,200~1,500rpm - Straight type: 15,000~30,000rpm 		
L	29	
D Ø5.0	ERM50A	CERM50S
D Ø7.0	-	CERM70A

AutoBone Collector®		
Description/Item code		Image/Guide
<ul style="list-style-type: none"> Used for autogenous bone collecting Comes in a Drill + Stopper set Recommended drilling speed: 300~600rpm Number of uses for the drill and stopper: 50 times <p>※ Before initial drilling, connect the stopper to the first stage locking and harvest autogenous bone while drilling 4mm into the second stage locking (after harvesting, stop the drill and remove as it is with autogenous bone kept in the stopper)</p>		
D	Short (18.94)	
Ø3.0	ABC304S	ABC304L
Ø4.0	ABC404S	ABC404L
Ø5.0	ABC504S	ABC504L
Ø6.0	ABC604S	ABC604L

HIOSSEN
IMPLANT

Ultra Kit (HULTRK)

For **Ultra-Wide**

Lower panel components

Open Wrench
SPOW



Ratchet Wrench
RCWC

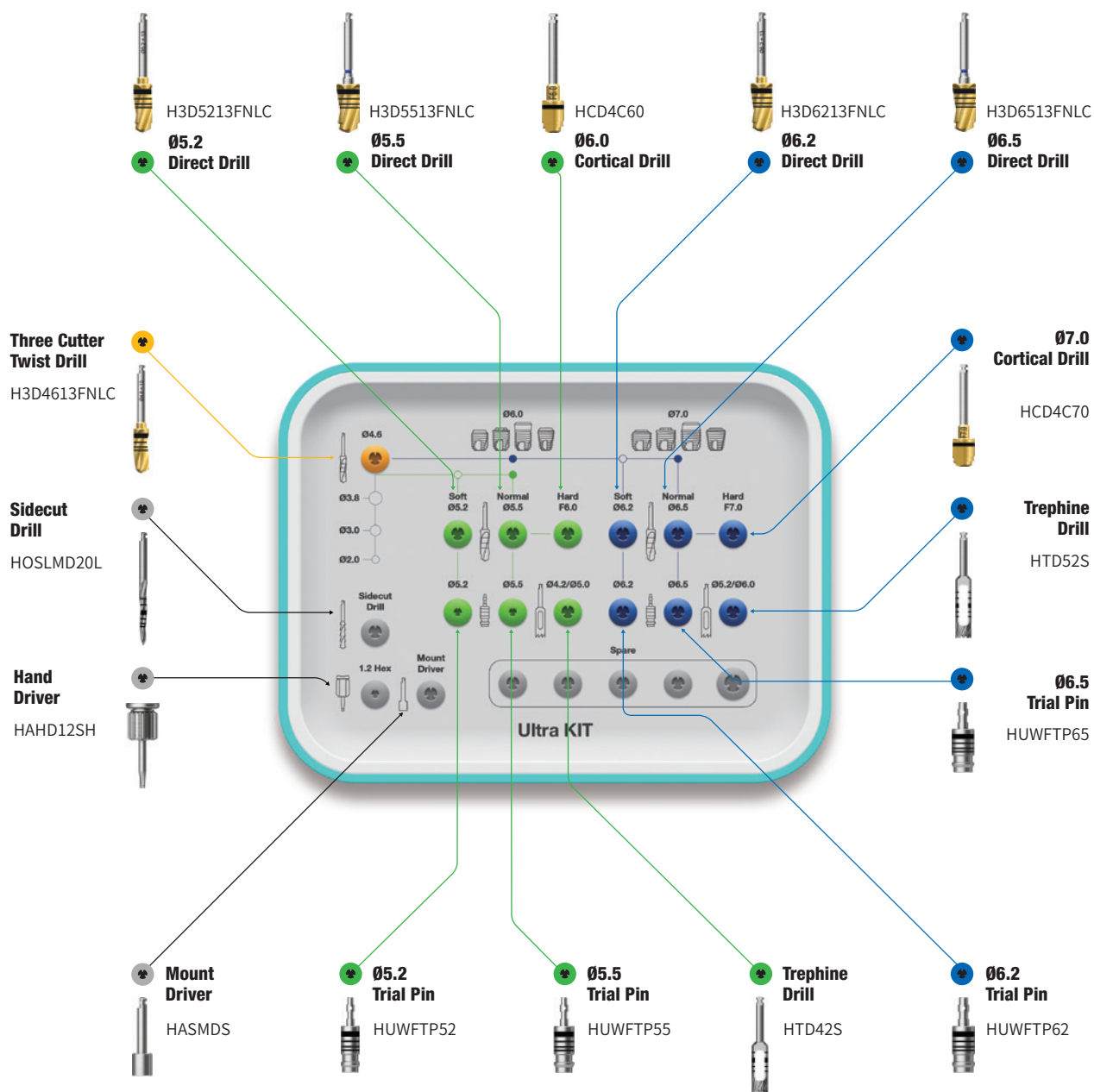

Ultra Kit Surgical Kit Instruments

Sidecut Drill			
Description		Item Code	Image
<ul style="list-style-type: none"> Forming a hole to facilitate initial drilling Bone density determined through drilling 		HOSLMD20L	

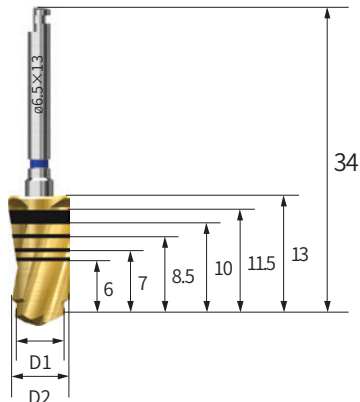
Direct Drill			
Description	D1/D2	Item code	Image/Guide
<ul style="list-style-type: none"> Direct drill: two-step drill that functions like a pilot and twist drill Final drilling is possible without using pilot drill Increases initial stability in an extraction socket due to the reduced dead space at the apex 	Ø4.6/5.2	H3D5213FNLC	
	Ø4.6/5.5	H3D5513FNLC	
	Ø5.5/6.2	H3D6213FNLC	
	Ø5.5/6.5	H3D6513FNLC	

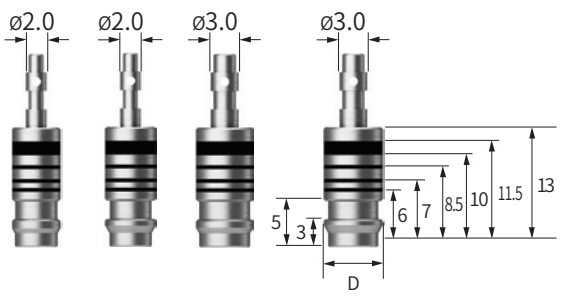
Trial Pin for Ultra-wide			
Description	D	Item code	Image/Guide
<ul style="list-style-type: none"> Measures the width and depth of a failed implant site Measures the drilling depth after using the direct drill as the final drill Also serves as a parallel pin 	Ø5.2	HUWFTP52	
	Ø5.5	HUWFTP55	
	Ø6.2	HUWFTP62	
	Ø6.5	HUWFTP65	

Ultra Kit Surgical Kit Instruments

Cortical Drill for Ultra-wide			
Description	D/Ø	Item code	Image
<ul style="list-style-type: none"> Trims cortical bone in hard bone cases (for ultra-wide type implants) Drill specifically designed for ultra-wide implant's unique diameter Drilling recommended until the bottom of the marker has been reached 	F6.0	HCD4C60	
	F7.0	HCD4C70	

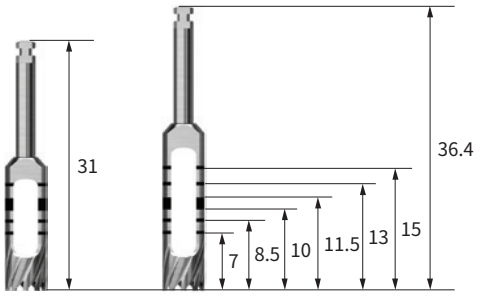
Trepine Drill		
Description/Item code		Image/Guide
<ul style="list-style-type: none"> Harvests bone or removes a failed implant Used to remove septal bone Can also be used as the initial drill for ultra-wide implants 		
D/Ø (Inner/Outer)	Short	
3.7/4.5	HTD37S	HTD37S
4.2/5.0	HTD42S	HTD42S
4.7/5.5	HTD47S	HTD47S
5.2/6.0	HTD52S	HTD52S
5.7/6.5	HTD57S	HTD57S
6.2/7.0	HTD62S	HTD62S

HIOSSEN
IMPLANT

Drilling Sequence III Type Straight Drill

EKIII | ETIII | SSIII

(Length: 10mm)

Ø3.2mm

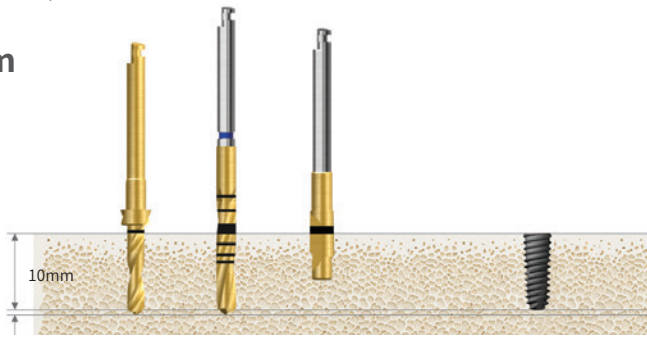

Bone Quality	Ø2.2 Drill	Ø2.7 Drill	F3.0 Cortical Drill 2	Ø3.0 Implant
Soft	▶			
Normal	▶	▶		Implant Placement
Hard	▶	▶	▶	

Ø3.5mm

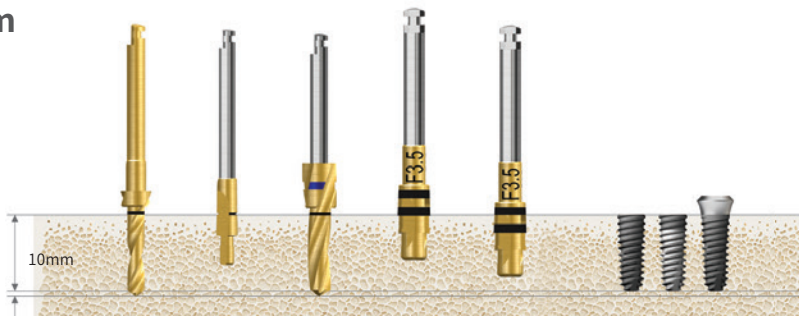

Bone Quality	Ø2.2 Drill	Ø2.0/3.0 Pilot Drill	Ø3.0 Drill	F3.5 Cortical Drill 3	F3.5 Cortical Drill 3	Ø3.5 Implant
Soft	▶	▶	▶			
Normal	▶	▶	▶	▶		Implant Placement
Hard	▶	▶	▶		▶	

Ø4.0mm



Bone Quality	Ø2.2 Drill	Ø2.0/3.0 Pilot Drill	Ø3.0 Drill	Ø3.3 Drill	F4.0 Cortical Drill 3	F4.0 Cortical Drill 3	Ø4.0 Implant
Soft	▶	▶	▶	▶			
Normal	▶	▶	▶	▶	▶		Implant Placement
Hard	▶	▶	▶	▶		▶	

Drilling Sequence III Type Straight Drill

EKIII | ETIII | SSIII

(Length: 10mm)

Ø4.5mm

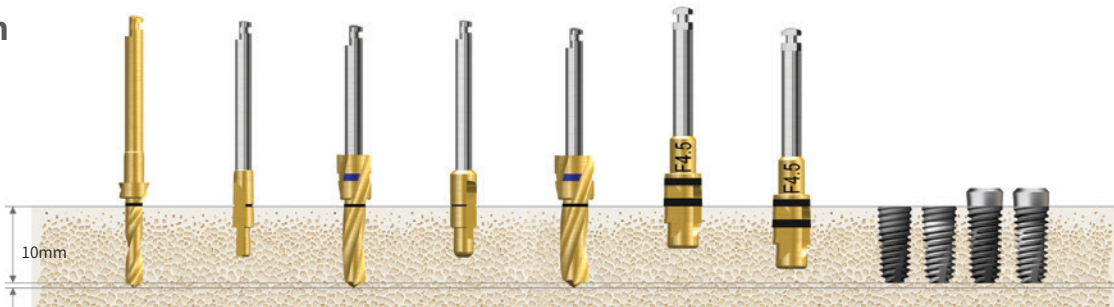

Bone Quality	Ø2.2 Drill	Ø2.0/3.0 Pilot Drill	Ø3.0 Drill	Ø3.0/3.8 Pilot Drill	Ø3.8 Drill	F4.5 Cortical Drill 3	F4.5 Cortical Drill 3	Ø4.5 Implant
Soft	▶	▶	▶	▶	▶			
Normal	▶	▶	▶	▶	▶	▶		Implant Placement
Hard	▶	▶	▶	▶	▶		▶	

Ø5.0mm



Bone Quality	Ø2.2 Drill	Ø2.0/3.0 Pilot Drill	Ø3.0 Drill	Ø3.0/3.8 Pilot Drill	Ø3.8 Drill	Ø4.3 Drill	F5.0 Cortical Drill 3	F5.0 Cortical Drill 3	Ø5.0 Implant
Soft	▶	▶	▶	▶	▶				
Normal	▶	▶	▶	▶	▶	▶	▶		Implant Placement
Hard	▶	▶	▶	▶	▶	▶		▶	

Ø5.5mm



Bone Quality	Ø2.2 Drill	Ø2.0/3.0 Pilot Drill	Ø3.0 Drill	Ø3.0/3.8 Pilot Drill	Ø3.8 Drill	Ø4.6 Drill	F5.5 Cortical Drill 3	F5.5 Cortical Drill 3	Ø5.5 Implant
Soft	▶	▶	▶	▶	▶	▶			
Normal	▶	▶	▶	▶	▶	▶	▶		Implant Placement
Hard	▶	▶	▶	▶	▶	▶		▶	

Recommended insertion torque ≤40Ncm.

ET implant insertion depth in normal/hard bone is placed 1mm deeper than the bone level, and the soft bone is placed at the bone level to maintain initial stability.

Drilling Sequence IV Type Straight Drill

ETIV

(Length: 10mm)

Ø4.0mm

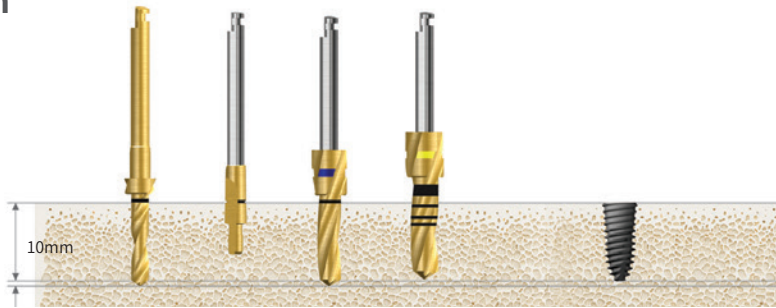

Bone Quality	Ø2.2 Drill	Ø2.0/3.0 Pilot Drill	Ø3.0 Drill	Ø3.0 Drill (Half)	Ø4.0 Implant
D4	▶				Implant Placement
Soft	▶	▶	▶	▶	

Ø4.5mm

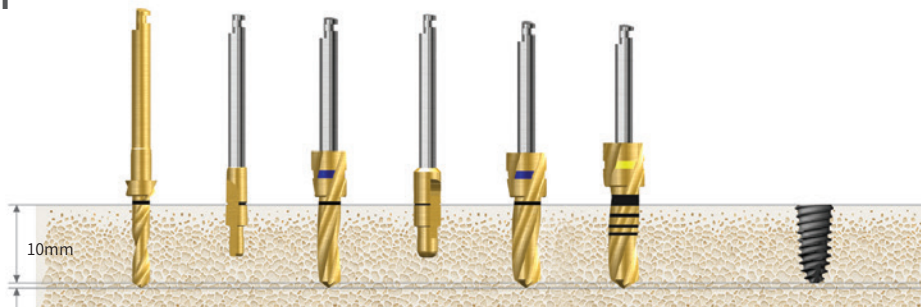

Bone Quality	Ø2.2 Drill	Ø2.0/3.0 Pilot Drill	Ø3.0 Drill	Ø3.0/3.8 Pilot Drill	Ø3.8 Drill	Ø4.1 Drill (Half)	Ø4.5 Implant
D4			▶				Implant Placement
Soft	▶	▶	▶	▶	▶	▶	

Ø5.0mm

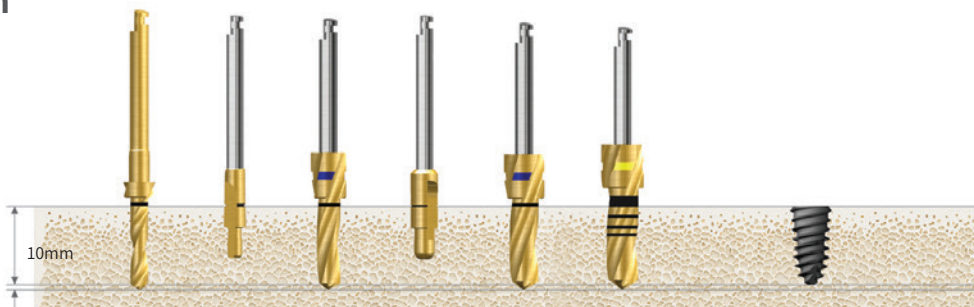

Bone Quality	Ø2.2 Drill	Ø2.0/3.0 Pilot Drill	Ø3.0 Drill	Ø3.0/3.8 Pilot Drill	Ø3.8 Drill	Ø4.6 Drill (Half)	Ø5.0 Implant
D4			▶				Implant Placement
Soft	▶	▶	▶	▶	▶	▶	

Drilling Sequence Ultra-wide Straight Drill

ETIV Ultra-Wide

(Length: 10mm)

Ø6.0mm

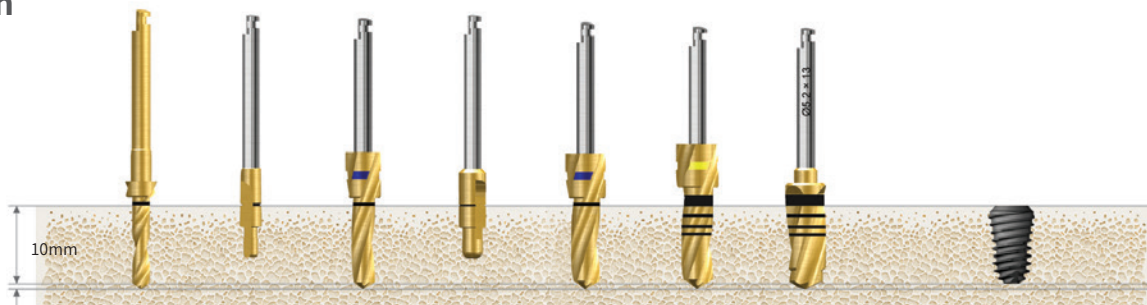

Bone Quality	Ø2.2 Drill	Ø2.0/3.0 Pilot Drill	Ø3.0 Drill	Ø3.0/3.8 Pilot Drill	Ø3.8 Drill	Ø4.6 Drill	Ø5.2 Direct Drill	Ø6.0 Implant
D4	▶	▶			▶			Implant Placement
Soft	▶	▶	▶	▶	▶	▶	▶	

Ø7.0mm



Bone Quality	Ø2.2 Drill	Ø2.0/3.0 Pilot Drill	Ø3.0 Drill	Ø3.0/3.8 Pilot Drill	Ø3.8 Drill	Ø4.6 Drill	Ø5.5 Direct Drill	Ø6.2 Direct Drill	Ø7.0 Implant
D4	▶	▶			▶	▶			Implant Placement
Soft	▶	▶	▶	▶	▶	▶	▶	▶	

Recommended insertion torque ≤40Ncm

Prosthetic Simple Kit (HPSK)

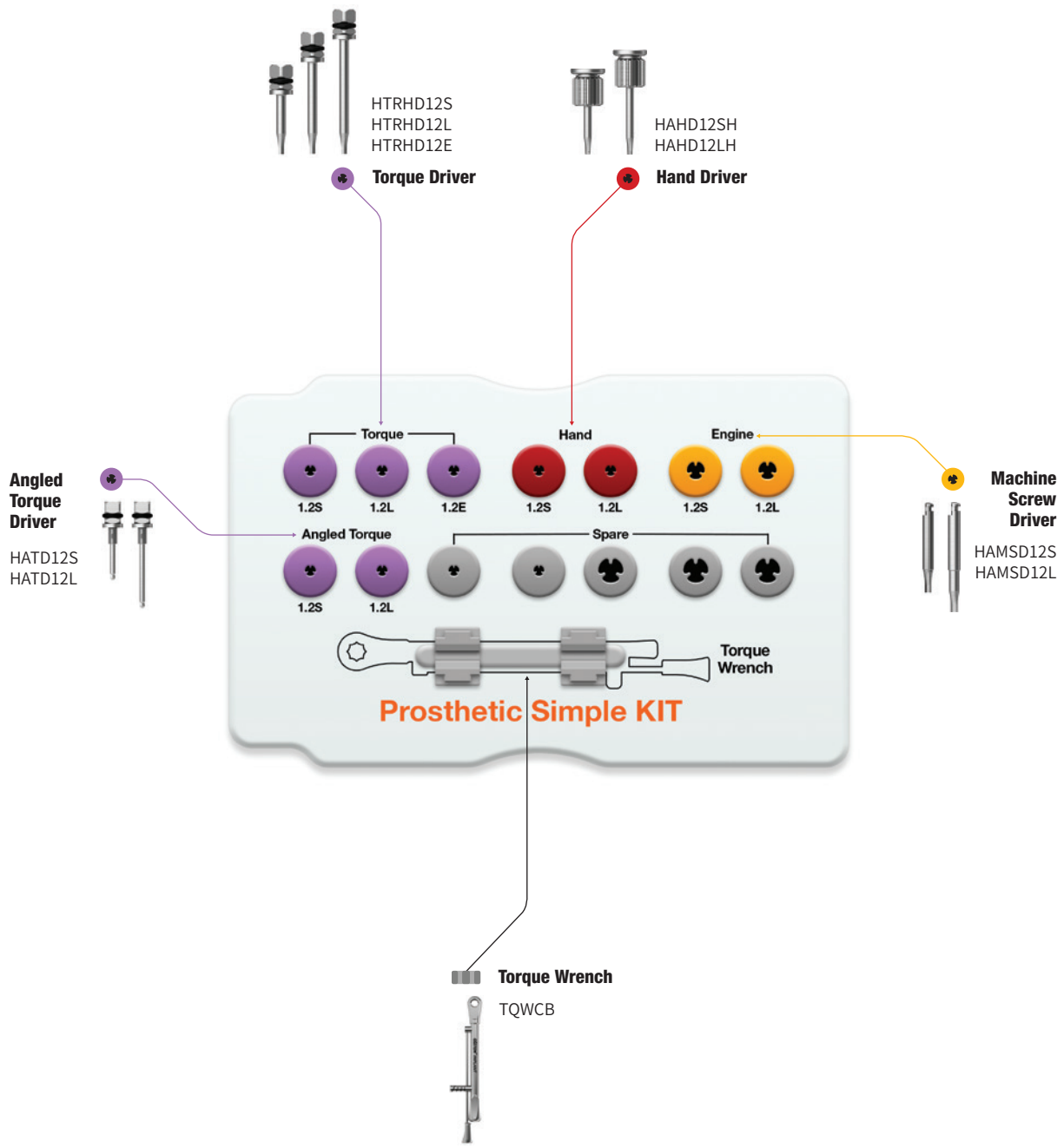

Prosthetic Kit (HPRSTKA)

Top Panel Components

Torque Wrench
TQWCB

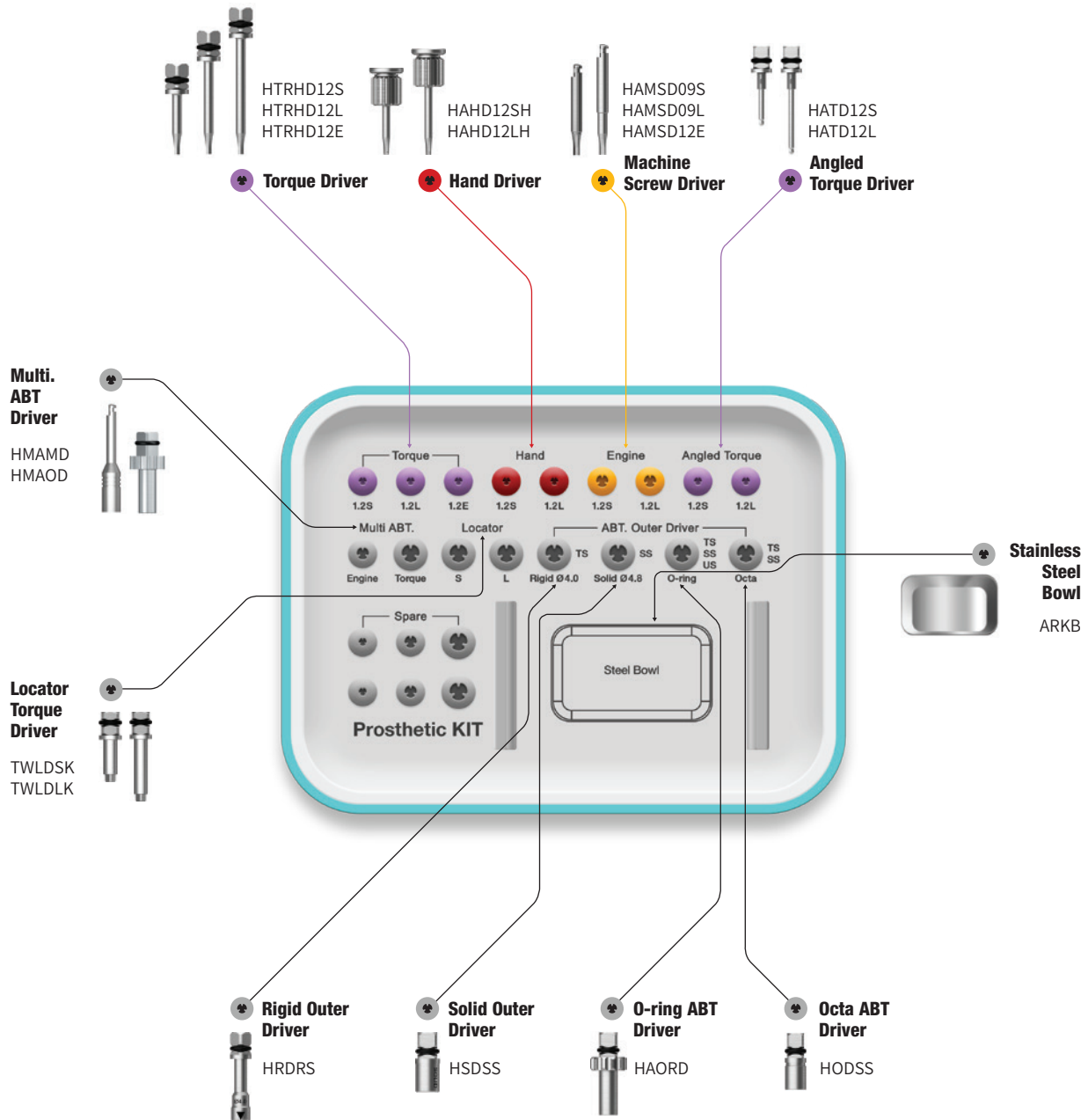

Prosthetic Kit Surgical Kit Instruments



Hand Driver					
Description	L	0.9 Hex	1.2 Hex	Image	
<ul style="list-style-type: none"> Manual driver Tip holding function (except internal hex type) Internal hex type length: 11mm 	Ex.Short (8)	HAHD09MSH	HAHD12MSH		
	Short (13)	HAHD09SH	HAHD12SH		
	Middle (15)	-	HAHD12MH		
	Long (18)	HAHD09LH	HAHD12LH		
	Ex.Long (25)	-	HAHD12EH		

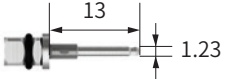
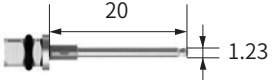

Machine Screw Driver					
Description	L	0.9 Hex	1.2 Hex	Image	
<ul style="list-style-type: none"> 1.2 hex driver for engine handpiece Tip holding function (except in internal hex type) Internal hex type length: 8mm 	Osstem Torque (5)	-	-		
	Short (5.6)	HAMSD09S	HAMSD12S		
	Long (11.6)	HAMSD09L	HAMSD12L		
	Ex.Long (17.6)	-	HAMSD12E		
<p>Application Driver Applied Products (common for hand, machine screw and torque driver)</p>		Cover screw (US mini)	Healing abutment, UCLA, Cemented abutment screw, Mount screw		

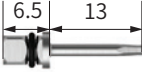
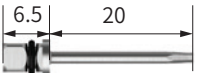
Torque Driver					
Description	L	0.5 Slot	0.9 Hex	1.2 Hex	Image
<ul style="list-style-type: none"> Driver for torque wrench Tip holding function May bend or break if excessive torque is applied Damage is possible even at low torque if not fully engaged Apply vertical pressure when applying torque driver (Do not tilt) If the tip is bent or stripped, replace immediately 	Ex.Short (8)	-	-	HTRHD12MS	
	Short (13)	HTRSD05S	HTRHD09S	HTRHD12S	
	Middle (15)	-	-	HTRHD12M	
	Long (20)	HTRSD05L	HTRHD09L	HTRHD12L	
	Ex.Long (25)	HTRSD05E	-	HTRHD12SE	

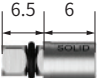
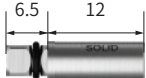
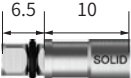
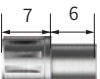
Angled Torque Driver				
Description	L	1.2 Hex	1.2 Hex (Set)	Image
<ul style="list-style-type: none"> • Driver for torque wrench • No holding function • Recommended tightening torque: 30Ncm (excessive torque causes fracture) • Do not remove tube to prevent fragmentation when broken • Recommended number of use: 10 times • Set: 3 per pack 	Short (13)	HATD12S	HATD12S3S	
	Long (20)	HATD12L	HATD12L3S	

Repair Torque Driver			
Description	L	1.2 Hex	Image
<ul style="list-style-type: none"> • Reduced diameter of shank compared to the Torque Driver (Ø2.1 → 1.6) • The diameter of the screw hole can be minimized during prosthetic repair or SCRIP procedures 	Short (13)	HTRHD12SR	
	Long (20)	HTRHD12LR	

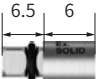
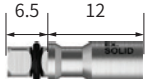
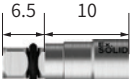
Solid Abutment Driver		Regular		Wide	
Description	Type	Short (6)	Long (12)	Short (10)	Long (L)
<ul style="list-style-type: none"> • Driver specific for solid abutments • Connect to the solid abutment by matching up the groove with the triangular indicator • Recommended tightening torque: 30Ncm 	Square	 HSDSS	 HSDSL	 HSD60S	-
	Round	 HSDRS	 HSDRL	-	-

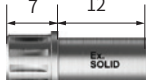
Excellent Solid Abutment Driver		Regular		Wide	
Description	Type	Short (6)	Long (12)	Short (10)	Long (L)
<ul style="list-style-type: none"> • Driver for Excellent Solid Abutments • Connect to the solid abutment by matching up the groove with the triangular indicator • Recommended tightening torque: 30Ncm 	Square	 HESDSS	 HESDSL	 HESD60S	-
	Round	 HESDRS	 HESDRL	-	-

Prosthetic Kit Surgical Kit Instruments

O-ring Abutment Driver		
Description	Item Code	Image
<ul style="list-style-type: none"> Driver for Stud Abutment 	HAORD	

Rigid Outer Driver				
Description	D/Ø (Abutment)	Short (16.5)	Long (21.5)	Image
<ul style="list-style-type: none"> Driver for Rigid Abutments Recommended tightening torque: 30Ncm 	Ø4.0	HRDMS	HORDML	
	Ø4.5	HRD45S	HRD45L	
	Ø5.0	HRDRS	HRDRL	
	Ø6.0	HRDWS	HRDWL	

Octa Abutment Driver			
Description	Type	Short	Long
<ul style="list-style-type: none"> Driver for Octa Abutments Recommended tightening torque: 30Ncm 	Square	12.5 HODSS	18.5 HDSL
	Round	13.4 HDRS	19.4 HDRL

Multi Abutment Machine Driver		
Description	Item Code	Image
<ul style="list-style-type: none"> Machine driver for Multi-Abutments 	HMAMD	

Abutment Holder		
Description	Item Code	Image
<ul style="list-style-type: none"> Used to hold abutments and help deliver them to hard-to-reach sites of the oral cavity 	HOABH	

Multi Abutment Outer Driver			
Description	Type	Item Code	Image
<ul style="list-style-type: none"> Torque driver for Multi-Abutments 	Normal	HMAODP	
	Rescue	HMAOD	

Locator Abutment Driver			
Description	Type	Item Code	Image
<ul style="list-style-type: none"> Torque driver for Locator Abutments 	Short	TWLDSK	
	Long	TWLDLK	

Torque Driver				
Description	Type	Short (10)	Long (15)	Image
<ul style="list-style-type: none"> It may not be fastened or disconnected when connecting a normal handpiece Driver should be used after matching the groove or section of the outer triangle and abutment Solid, excellent solid driver is compatible only with Ø4.8 1.2 hex type L is 5 	1.2 Hex	HTH12S	-	
	Rigid 4.0	HTR40S	HTR40L	
	Rigid 4.5	HTR45S	HTR45L	
	Rigid 5.0	HTR50S	HTR50L	
	Rigid 6.0	HTR60S	HTR60L	
	Solid	HTS48S	HTS48L	
	Excellent Solid	HTE48S	HTE48L	

Path Probe for ET			
Description	Connection	Item Code	Image
<ul style="list-style-type: none"> Tool to check path and measure gingival height after ET implant placement C = Connection 	Mini	GIPAP-3016A	
	Regular	GIPAP-3516A	

Path Probe for EK			
Description	Connection	Item Code	Image
<ul style="list-style-type: none"> Tool to check path and measure gingival height after EK implant placement C = Connection 	Regular	HKSPPR	

Prosthetic Kit Surgical Kit Instruments

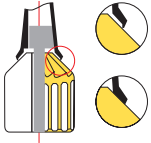
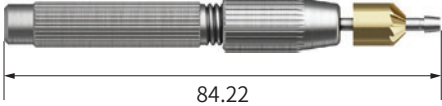
Finishing Reamer Set		
Description	Item Code	Image
<ul style="list-style-type: none"> Tool used to remove the excess cast after plastic coping is set <p>Reamer user guide</p> <ol style="list-style-type: none"> Select a reamer tip that is the same size as Abutment size and connect it to the burn-out cylinder Firmly grasp the casting body and rotate the Reamer Bite with consistent force Ream the body until it is clean and free of the excess casting 	HFRSC	

Reamer Bite		
Description	Item Code	Image
<ul style="list-style-type: none"> Tool used to remove the excess cast after plastic coping is set 	HFRBC	

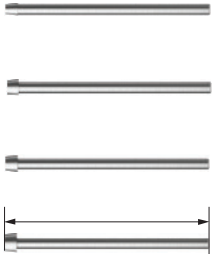
Reamer Tip for Rigid Abutment			
Description	D/Ø	Item Code	Image
<ul style="list-style-type: none"> Tool used to remove the excess cast after plastic coping is set 	Ø4.0	HGSRFRT400	
	Ø4.5	HGSRFRT450	
	Ø5.0	HGSRFRT500	
	Ø6.0	HGSRFRT600	

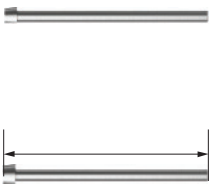
Reamer Tip for Solid, Excellent Solid Abutment				
Description	Platform	Solid	Ex. Solid	Image
<ul style="list-style-type: none"> Tool used to remove the excess cast after plastic coping is set For both solid Ø6.0 and excellent solid Ø4.8 P = Platform 	Regular Ø4.8	HFRTS480	HF RTE480	
	Wide Ø6.0	HFRTS600	HF RTE600	

HIOSSEN
IMPLANT

ESR Kit Easy Screw Removal Kit (HESRK)

※ ESR (EK) Kit: HKESRK

For

- EKIII
- ETIII/IV
- SSIII
- Ultra-Wide

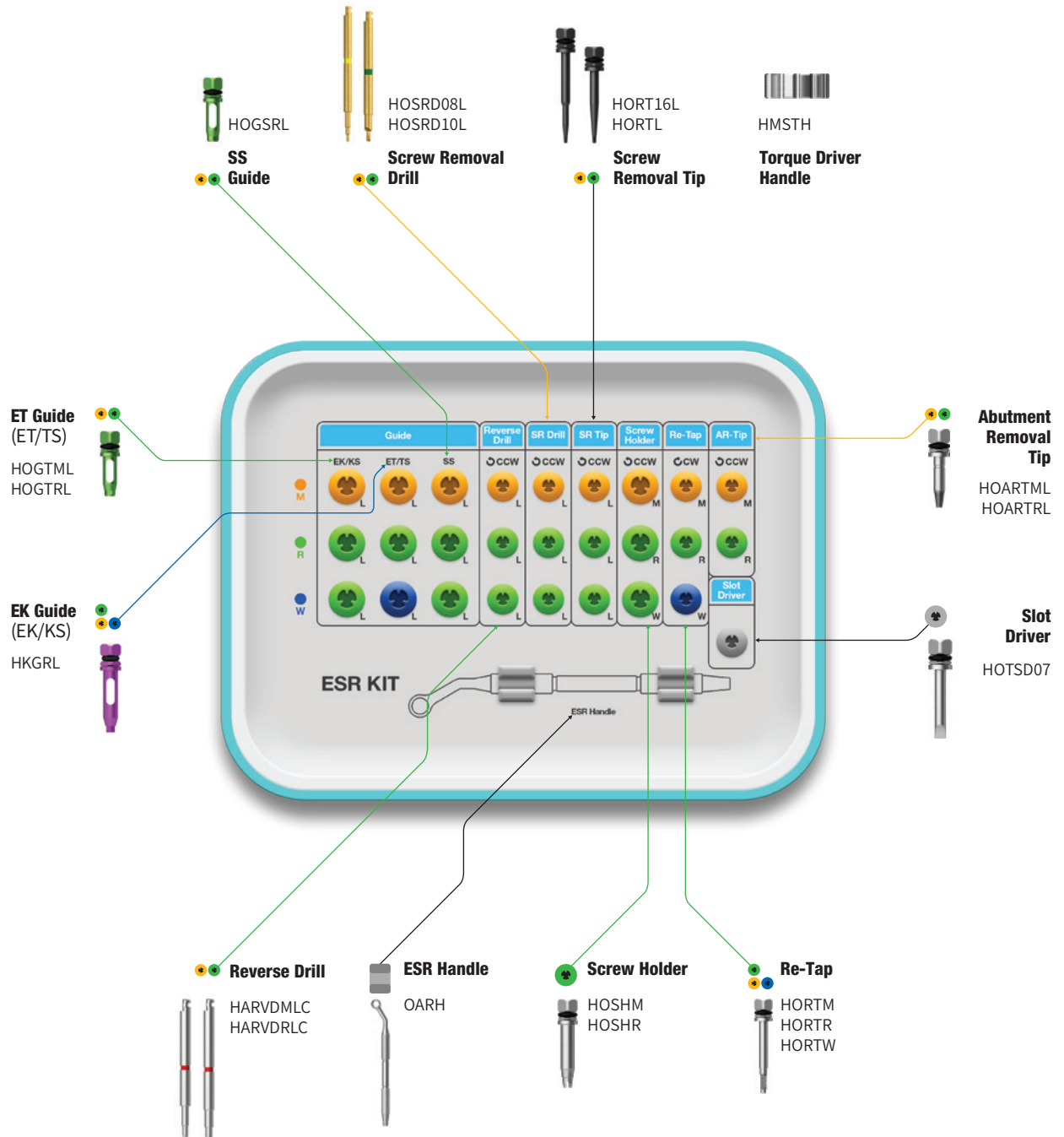





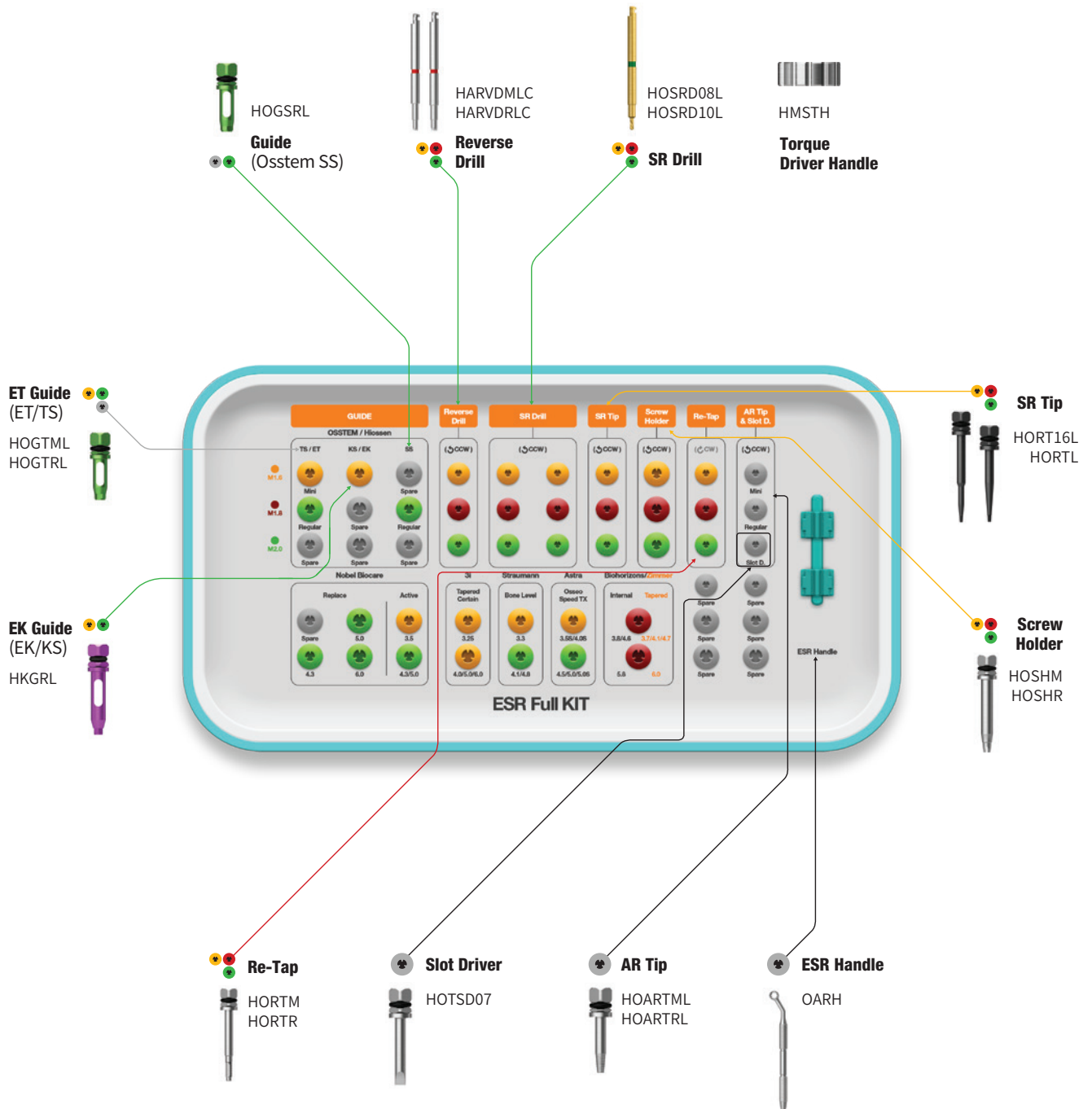









ESR Full Kit Easy Screw Removal Full Kit (HESRFK_US)

For **Nobel Biocare** Active/Replace / **Straumann** Bone Level / **Astra** Osseo Speed TX
3i Full OSSEOTITE Tapered Certain / **3i** Tapered / **BioHorizons**® Internal





ESR Full Kit Surgical Kit Instruments

Guide							
Description							
<ul style="list-style-type: none"> • Connected to the implant to center and prevent shaking of the reverse driver, SR drill and retap • Choose spec of guide according to implant type and diameter (6 overseas companies' internal and submerged type products) • Short or long used according to intermaxillary distance • Used in combination with the ESR handle • C = Connection/the number of use: 10 times 							
Osstem							
Type	Length	C	Mini	Regular	Wide	Image	
ET(TS)	Short		HGTMS	HOGTRS	-		
	Long		HOGTML	HOGTRL	-		
EK(KS)	Short		-	HKGRS	-		
	Long		-	HKGRL	-		
SS	Short		-	HGSRS	HGSRS		
	Long		-	HOGSRL	HOGSRL		
Nobel Biocare							
Type	Length	F	Ø3.5	Ø4.3	Ø5.0	Ø6.0	Image
Active	Short		HGNA01S	HGNA02S	HGNA02S	-	
	Long		HGNA01L	HGNA02L	HGNA02L	-	
Replace	Short		-	HGNR02S	HGNR03S	HGNR04S	
	Long		-	HGNR02L	HGNR03L	HGNR04L	
Type	Length	F	Ø3.3	Ø3.75	Ø4.0	Ø5.0	Image
MKIII	Short		HGUMS	HGURS	HGURS	HGUWS	
	Long		HHGUML	HOGURL	HOGURL	HOGUWL	
Straumann							
Type	Length	F	NC (3.3)	RC (4.1)	RC (4.8)		Image
Bone Level	Short		HGSB01S	HGSB02S	HGSB02S		
	Long		HGSB01L	HGSB02L	HGSB02L		
Type	Length	F	RN (3.3 / 4.1 / 4.8)		WN (4.8)		Image
Roxolid SLActive	Short		HGSTRS		HGSTRS		
	Long		HGSTRL		HGSTRL		
Astra							
Type	Length	F	Small (3.5 S / 4.0 S)		Large (4.5 / 5.0 / 5.0S)		Image
Osseo Speed TX	Short		HGA001S		HGA002S		
	Long		HGA001L		HGA002L		
Zimvie (Zimmer)							
Type	Length	F	Green (3.7 / 4.1 / 4.7)		Green (6.0)		Image
Tapered	Short		HGZB01S		HGZB02S		
	Long		HGZB01L		HGZB02L		



BioHorizons					
Type	Length	F	Yellow / Green	Blue	Image
Internal (Tapered Bone Level)	Short		HGZB01S	HGZB02S	
	Long		HGZB01L	HGZB02L	
Type	Length	F	Ø3.5	Ø4.0 / 5.0 / 6.0	
External	Short		HGUMS	HGURS	
	Long		HHGUML	HOGURL	
3i					
Type	Length	F	3.25	4.0 / 5.0 / 6.0	Image
Full Osseotite Tapered Certain	Short		HGIF01S	HGIF02S	
	Long		HGIF01L	HGIF02L	
Full Osseotite Tapered	Short		-	HGURS	
	Long		-	HOGURL	



Reverse Drill				
Description	Type	Short	Long	Image
<ul style="list-style-type: none"> Used to remove a fractured screw To be used in conjunction with the guide If the red marking of the reverse driver is visible on the guide, remove the fractured screw using a screw holder Direction of rotation: Counterclockwise Recommended number of usage: 10 times 	M1.6	-	HARVDMLC	
	M1.8	HARVDRSC	HARVDRLC	
	M2.0	HARVDRSC	HARVDRLC	



Screw Removal Drill (SR Drill)				
Description	Type	Short	Long	Image
<ul style="list-style-type: none"> Used to create a hole in the fractured screw Make sure to connect the guide, irrigate and suction to remove any debris Available in long and short lengths for different intermaxillary distances Drill until the colored marking on the drill is no longer visible through the guide Recommended speed: 1,200~1,500 rpm (counterclockwise) Recommended number of uses: 5 times Connect the guide before use/Do not apply excessive vertical force/Do not clean with hydrogen peroxide 	M1.6	HSRD08S	HOSRD08L	
	M1.8	HSRD09S	HSRD09L	
	M2.0	HSRD10S	HOSRD10L	



Torque Driver Handle		
Description	Item Code	Image
<ul style="list-style-type: none"> Manual handle for SR Tip, AR Tip, screw holder 	HMSTH	

ESR Full Kit Surgical Kit Instruments



Reverse Driver				
Description	F	Short	Long	Image
<ul style="list-style-type: none"> Reverse Driver Used to remove a fractured screw To be used in conjunction with the guide Insert until the red band is in the Guide and turn counterclockwise to remove the screw Use manually/Rotate counterclockwise/ Number of usages: 10 times 	Mini	-	HRVDML	
	Regular/ Wide	HRVDRS	HRVDRL	

Screw Removal Tip (SR Tip)				
Description	Type	Short	Long	Image
<ul style="list-style-type: none"> Removes a fractured screw by engaging into the hole created by the Screw Removal Drill Rotation direction: counterclockwise 	M1.6	HRT16S	HORT16L	
	M1.8	HRT18S	HRT18L	
	M2.0	HRTS	HORTL	



Screw Holder			
Description	Type	Item Code	Image
<ul style="list-style-type: none"> Grasps onto a protruding fractured screw to unscrew it Color-coded for easy recognition Rotation direction: counterclockwise 	M1.6	HOSHM	
	M1.8	HSHR18	
	M2.0	HOSHR	

Re-Tap			
Description	Type	Item Code	Image
<ul style="list-style-type: none"> Re-threads the internal connection of a implant Connects to a torque wrench or ratchet wrench to re-thread by hand 	M1.6	HORTM	
	M1.8	HRTR18	
	M2.0	HORTR	

ESR Handle		
Description	Item Code	Image
<ul style="list-style-type: none"> Stabilizes the Guide to the implant 	OARH	

Abutment Removal Tip (AR Tip)					
Description	F	Short	Long	Ex. Long	Image
<ul style="list-style-type: none"> Removes fractured or jammed abutments and mounts from the implant Insert into fractured abutment hole, turn counterclockwise, and rock back and forth to loosen and remove with forceps Mini: it can be used to remove a screw with a stripped hex <ul style="list-style-type: none"> To remove the screw, engage the tip into the stripped hex and rotate counterclockwise 	Mini	HARTMS	HOARTML	HARTMEL	
	Regular	HARTRS	HOARTRL	HARTREL	

Slot Driver		
Description	Item Code	Image
<ul style="list-style-type: none"> Used to unscrew a screw, healing abutment, cover screw, or abutment screw with a stripped hex after creating a slot with a Ø0.8 bur 	HOTSD07	

Transfer Abutment Separate Tool			
Description		Item Code	Image
<ul style="list-style-type: none"> Remove jammed abutment of non-hex type transfer abutment The tip is for mini platform abutments; the next step for regular platform Remove the abutment screw, insert Separate Tool Body into the abutment, tighten clockwise with Driver, and remove the abutment. If there is difficulty separating the abutment, attach a ratchet wrench for extra torque 	Driver	HTASD	
	Body	HTASB	
	Set	HTAST	

EIR Kit Easy Implant Removal Kit (HKSFRK)

※ EIR (EK) Kit: HKSFRK





For

- EKIII
- ETIII/IV
- SSIII
- Ultra-Wide

Top panel components

Implant Wrench
HFRDFE



- | | | | |
|---|--|---|--|
| <p>Normal mode</p>  <p>HKSFRSM35
HKSFRSR40
HKSFRSW50</p> <p>Remover Screw
EK/KS</p> | <p>Normal mode</p>  <p>HFRSM35
HFRSR40
HFRSW50</p> <p>Remover Screw
ET/TS/SS</p> | <p>Fracture mode</p>  <p>HFRSM35F
HFRSR40F
HFRSW50F</p> <p>Remover Screw
ET/TS/SS</p> |  <p>HFRSDM23
HFRSDR25
HFRSDW30</p> <p>Screw Driver</p> |
|---|--|---|--|

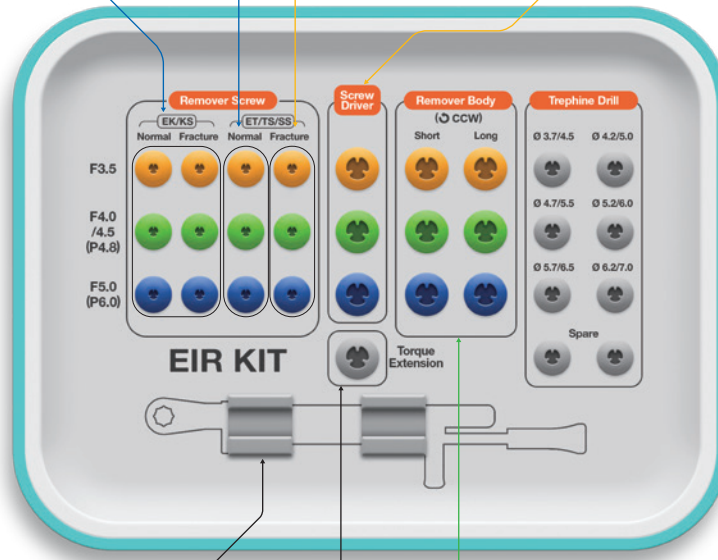



- Torque Wrench**
HTW400B
- 

- Torque Extension**
HOTE
- 

- Remover Body**
- HFRBM35S
 - HFRBM35L
 - HFRBR40S
 - HFRBR40L
 - HFRBW50S
 - HFRBW50L
- 

EIR Full Kit Surgical Kit Instruments

Remover Screw					
Description			Image		
<ul style="list-style-type: none"> When securely fastened to the implant, it serves as a supporting structure for the Remover Body Use the proper type that matches the diameter of the implant to be removed (ET/SS/US, normal/fracture) Fracture type is specifically for removing a fractured implant Recommended tightening torque: regular/wide 100Ncm, mini 80Ncm <p>※ Disposable; do not reuse</p>					
Osstem					
Type	Mode	Mini Ø3.5	Regular Ø4.0~4.5/P4.8	Wide Ø5.0/P6.0	
ET/SS	Normal	HFRSM35 (3N)	HFRSR40 (4N)	HFRSW50 (5N)	
	Fracture	HFRSM35F (3F)	HFRSR40F (4F)	HFRSW50F (5F)	
EK	Normal	HKSFRSM35 (KS3N)	HKSFRSR40 (KS4N)	HKSFRSW50 (KS5N)	
	Fracture	HKSFRSM35F (KS3F)	HKSFRSR40F (KS4N)	HKSFRSW50F (KS5N)	
Nobel Biocare					
Type	Mode	Mini Ø3.5	Regular Ø4.3	Wide Ø5.0/6.0	
Active	Normal	HFRSMNA35 (N1)	HFRSR40 (4N)	HFRSW50 (5N)	
	Fracture	HFRSMNA35F (N2)	HFRSR40F(4F)	HFRSW50F (5F)	
Replace	Normal	HFRSMNR35 (N3)	HFRSR40 (4N)	HFRSW50 (5N)	
	Fracture	HFRSMNR35F (N4)	HFRSR40F (4F)	HFRSW50F (5F)	
Straumann					
Type	Mode	Mini Ø3.3	Regular Ø4.1	Wide Ø4.8	
Bone Level	Normal	HFRSMS33 (S1)	HFRSRS41 (S2)	HFRSWS48 (S3)	
	Fracture	HFRSMS33F (S4)	HFRSRS41F (S5)	HFRSWS48F (S6)	
Astra					
Type	Mode	Mini Ø3.5	Regular Ø4.0	Regular Ø4.5	Wide Ø5.0
Osseo Speed TX	Normal	HFRSMNA35 (N1)	HFRSRA40 (A1)	HFRSR40 (4N)	HFRSW50 (5N)
	Fracture	HFRSMNA35F (N2)	HFRSRA40F (A2)	HFRSR40F (4F)	HFRSW50F (5F)
3i					
Type	Mode	Mini Ø3.25	Regular Ø4.0	Wide Ø5.0/6.0	
Full Osseotite Tapered Certain	Normal	HFRSMS33 (S1)	HFRSRI40 (S2)	HFRSWI50 (S3)	
	Fracture	HFRSMS33F (S4)	HFRSRI40F (S5)	HFRSWI50F (S6)	
Zimmer					
Type	Mode	Mini Ø3.7	Regular Ø4.1	Wide Ø4.7	Ultra-Wide Ø6.0
Tapered	Normal	HFRSMZ37 (Z1)	HFRSRZ41 (Z2)	HFRSWZ47 (Z3)	HFRSWZ60 (Z4)
	Fracture	HFRSMZ37F (Z4)	HFRSRZ41F (Z6)	HFRSWZ47F (Z7)	HFRSWZ47F (Z7)
Biohorizons					
Type	Mode	Mini Ø3.8	Regular Ø4.6	Wide Ø5.8	
Internal	Normal	HFRSRZ41 (i1)	HFRSWZ47 (i2)	HFRSWZ60 (i3)	
	Fracture	HFRSRZ41F (i4)	HFRSWB46F (i5)	HFRSWB46F (i6)	

Screw Driver			
Description	Type	Item Code	Image
<ul style="list-style-type: none"> Connects and fastens the Remover Screw to the implant Recommended tightening torque: regular/wide 100Ncm, mini 80Ncm 	Mini	HFRSDM23	
	Regular	HFRSDR25	
	Wide	HFRSDW30	

Remover Body				
Description	Type	Short	Long	Image
<ul style="list-style-type: none"> Connects to the Remover Screw to apply torque to remove the implant Select the correct type that matches the diameter of the implant to be removed <p>※ Disposable; do not reuse</p>	Mini	HFRBM35S	HFRBM35L	
	Regular	HFRBR40S	HFRBR40L	
	Wide	HFRBW50S	HFRBW50L	
		HFRBW57S	HFRBW57L	
	Ultra-Wide	HFRBUW60S	HFRBUW60L	

Torque Extension		
Description	Item Code	Image
<ul style="list-style-type: none"> Extends the length of the screw driver and remover body (by 10mm) 	HOTE	

Torque Wrench		
Description	Item Code	Image
<ul style="list-style-type: none"> Tightens Screw Driver and removes the implant using the Remover Body Applies up to 400Ncm of torque (markers at 80/100/200/300/400Ncm) Torque by pulling the bar back until it reaches the desired torque value marking Clean and sterilize for storage 	HTW400B	

Implant Wrench		
Description	Item Code	Image
<ul style="list-style-type: none"> Wrench used to separate the implant from the Remover Body 	HFRDFE	

IM-Cure Kit (HICK)

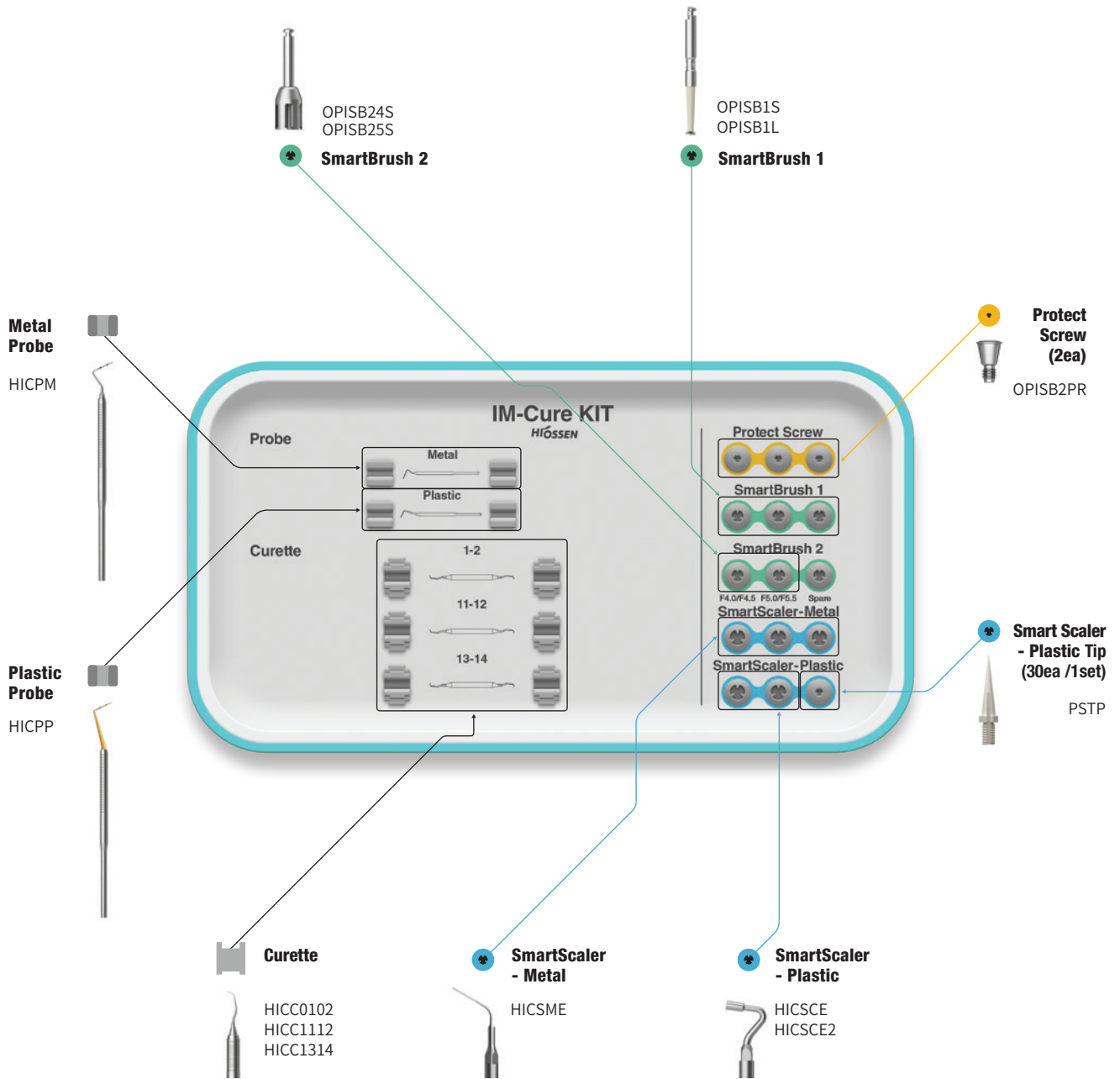

IM-Cure Kit Surgical Kit Instruments

Metal Probe		
Description	Item Code	Image
<ul style="list-style-type: none"> Used to diagnose periodontal disease Measures pocket depth/size Marking lines of 1mm increments 	HICPM	

Plastic Probe		
Description	Item Code	Image
<ul style="list-style-type: none"> Used to diagnose periodontal disease Measures pocket depth/size Marking lines of 1mm increments Plastic material prevents scratches on implant Flexible probe makes it ideal for curved shape of alveolar bone Autoclavable 	HICPP	

Curette			
Description	Type	Item Code	Image
<ul style="list-style-type: none"> Tool to remove granulation tissue firmly attached to a specific area Gracey curette 01-02: used for removal of anterior tissue 11-12: used for removal of ganglion tissue 13-14: used to remove the tissue from the distal part of posterior teeth 	01-02	HICC0102	
	11-12	HICC1112	
	13-14	HICC1314	

Protect Screw			
Description	Type	Item Code	Image
<ul style="list-style-type: none"> Protect the implant's internal connection when using the SmartBrush 1 & 2 Torque Using a 1.2 hex driver, tighten to about 5Ncm 	Mini	OPISB2PM	
	Regular	OPISB2PR	

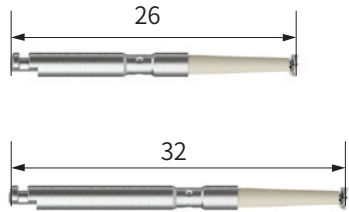
SmartBrush 1			
Description	Short	Long	Image
<ul style="list-style-type: none"> Bristle designed for effective debridement of the implant surface After removing the patient's prosthesis and abutment, connect the protect screw before using Recommended speed: 1,200~1,500rpm Recommended use time: approximately 1 minute per screw thread (not recommended over 4 minutes) Must use irrigation and suction during polishing <p>※ Disposable. Do not reuse</p>	OPISB1S	OPISB1L	

IM-Cure Kit Surgical Kit Instruments

SmartBrush 2				
Description	D/Ø	Short	Long	Image
<ul style="list-style-type: none"> Debride implant After removing the patient's prosthesis and abutment, connect the protect screw before using Must use irrigation and suction during polishing Recommended speed: 1,200~1,500rpm Recommended use time: 1~2 minutes Excessive use longer than 3 minutes may cause the product to break or bend 	F3.0/F3.5	OPISB23S	OPISB23L	
	F4.0/F4.5	OPISB24S	OPISB24L	
	F5.0/F5.5	OPISB25S	OPISB25L	
	F6.0	OPISB26S	OPISB26L	
	F7.0	OPISB27S	OPISB27L	

SmartScaler - Metal			
Description	Brand	Item Code	Image
<ul style="list-style-type: none"> Used to remove substances such as tartar by connecting it to an ultrasonic scaler Secondary use after using SmartBrush 1 or SmartBrush 2 Easy to bend tip for easy access EMS, KaVo, SATELEC specifications 	EMS	HICSME	 <p>Bendable</p>
	KaVo	HICSMK	
	SATELEC	HICSMS	

SmartScaler - Plastic				
Description	Brand	125°	100°	Image
<ul style="list-style-type: none"> Used in combination with SmartScaler plastic tip Do not use for removal of debris on the implant surface EMS, KaVo, SATELEC specifications A = Angle 	EMS	HICSCE	HICSCE2	 <p>125° 100°</p>
	KaVo	HICSCK	HICSCK2	
	SATELEC	HICSCS	HICSCS2	

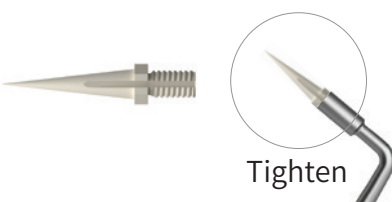
SmartScaler Plastic Tip		
Description	Item Code	Image
<ul style="list-style-type: none"> Used to remove substances from abutment or crown by attaching the SmartScaler ※ Do not use to implant surface Packing unit: 30 per set 	PSTP	 <p>Tighten</p>

HIOSSEN
IMPLANT

CAS Kit (HCRSNK)

For **EKIII** **ETIII/IV** **SSII/III** **Ultra-Wide**

Top panel components

Hydraulic Membrane Lifter Tube
SNMT



Lower panel components

Bone Carrier Head
SNBCH30



Bone Carrier
SNBCS35



Bone Condenser
SNBC1114

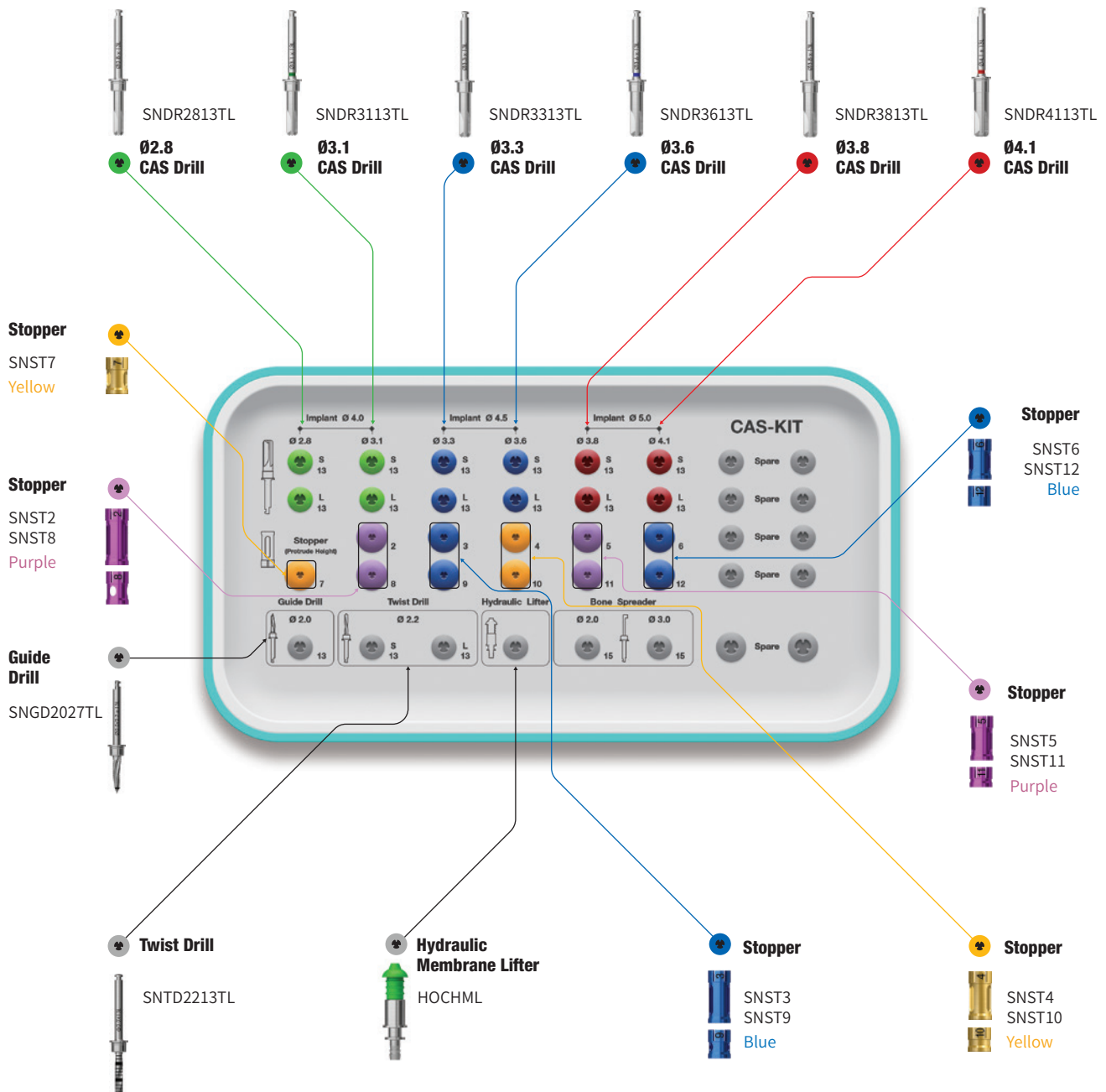

CAS Kit Surgical Kit Instruments

CAS Drill				
Description	D/Ø	Short	Long	Image
<ul style="list-style-type: none"> Specialized drill designed to penetrate the sinus floor without damaging the Schneiderian membrane by forming a conical bone lid Four blade drill design provides superior bone removing capability from low to high speeds, and can collect autogenous bone at low speeds Safely advance to the floor of the sinus using stoppers (1mm increments) Final drill diameter is based on bone density, regardless of the implant type (straight or tapered) Recommended speed: 400~800rpm (For beginner: 400rpm) 	Ø2.8	SNDR2813TS	SNDR2813TL	
	Ø3.1	SNDR3113TS	SNDR3113TL	
	Ø3.3	SNDR3313TS	SNDR3313TL	
	Ø3.6	SNDR3613TS	SNDR3613TL	
	Ø3.8	SNDR3813TS	SNDR3813TL	
	Ø4.1	SNDR4113TS	SNDR4113TL	

Guide Drill			
Description	D/Ø	Item Code	Image
<ul style="list-style-type: none"> Drill to mark the implant placement site Side cutting blades can be used to modify the side walls of the extraction socket Line marking 2mm from the apex of drill 	Ø2.0/2.7	SNGD2027TL	



Ø2.2 Twist Drill			
Description	D/Ø	Item Code	Image
<ul style="list-style-type: none"> Recommended to under-drill by 1mm below the floor of the sinus Use with stoppers for safe and controlled drilling Apex tip measures an additional 0.6mm 	Ø2.2	SNTD2213TL	

Hydraulic Membrane Lifter Set			
Description	D/Ø	Item Code	Image
<ul style="list-style-type: none"> Hydraulic pressure is used to separate and lift the sinus membrane Securely fits Ø2.8~Ø4.1 CAS drilled osteotomies 	Ø2.6/6.0	HOCHML	

Stopper											
<ul style="list-style-type: none"> Laser mark numbers indicates drilling depth Color-coded by length Recommended number of usage: 50 times 											
Length	2	3	4	5	6	7	8	9	10	11	12
Item Code	SNST2	SNST3	SNST4	SNST5	SNST6	SNST7	SNST8	SNST9	SNST10	SNST11	SNST12
Color	Purple	Blue	Yellow	Purple	Blue	Yellow	Purple	Blue	Yellow	Purple	Blue

CAS Kit Surgical Kit Instruments

Bone Carrier		
Description	Item Code	Image
<ul style="list-style-type: none"> Handle for the bone carrier head Connects the bone carrier head and tighten at the opposite end Connects both heads (SNBCH30 or SNBCH35) 	SNBCS35	

Bone Carrier Head			
Description	D/Ø	Item Code	Image
<ul style="list-style-type: none"> Cone shaped with an extended tip that reaches the sinus cavity and prevents bone material from spilling out SNBCH30 for Ø3.1/3.3 CAS drilled osteotomy SNBCH35 for Ø3.6/3.8/4.1 CAS drilled osteotomy Fill the reservoir (up to the marker) with bone material in small quantities using the bone condenser. Repeat the process as necessary 	Ø3.1	SNBCH30	
	Ø3.6	SNBCH35	

Bone Condenser		
Description	Item Code	Image
<ul style="list-style-type: none"> Safely pushes bone material through the bone carrier into the sinus cavity SNBCH30: use Ø1.1/SNBCH35: use Ø1.4 	SNBC1114	

Hydraulic Membrane Lifter Tube		
Description	Item Code	Image
<ul style="list-style-type: none"> Tubing to connect the hydraulic membrane lifter to the saline filled syringe 	SNMT	

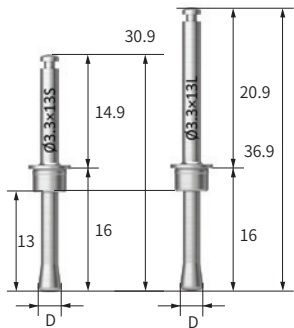
Membrane Lifter				
Description	D/Ø	Short	Long	Image
<ul style="list-style-type: none"> Round shape with no cutting edges for safe membrane lifting Select Membrane Lifter diameter according to the CAS drill diameter used (head diameter: CAS drill diameter -0.2mm) Use CAS stoppers to control length Recommended speed: 30~50rpm (Recommended speed for beginner: 30rpm) Be sure to spray water when using 	Ø2.6	SNML2813TS	SNDR2813TL	
	Ø2.9	SNML3113TS	SNDR3113TL	
	Ø3.1	SNML3313TS	SNDR3313TL	
	Ø3.4	SNML3613TS	SNDR3613TL	
	Ø3.6	SNML3813TS	SNDR3813TL	
	Ø3.9	SNML4113TS	SNDR4113TL	

Depth Gauge		
Description	Item Code	Image
<ul style="list-style-type: none"> Checks for access into the sinus cavity and measures the thickness of residual bone 	SNDBG	

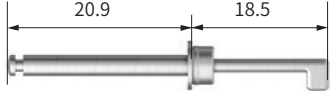
Bone Spreader			
Description	D/Ø	Item Code	Image
<ul style="list-style-type: none"> Spreads bone graft material in the sinus cavity Used with CAS stoppers Recommended speed: 30rpm or less 	Ø2.0	SNBS2015T	
	Ø3.0	SNBS3015T	

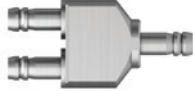
Y-Connector		
Description	Item Code	Image
<ul style="list-style-type: none"> Y-type connecting tool capable of simultaneous hydraulic pressure elevation in two osteotomies 	SNYCT	

LAS Kit (HLRSNK)

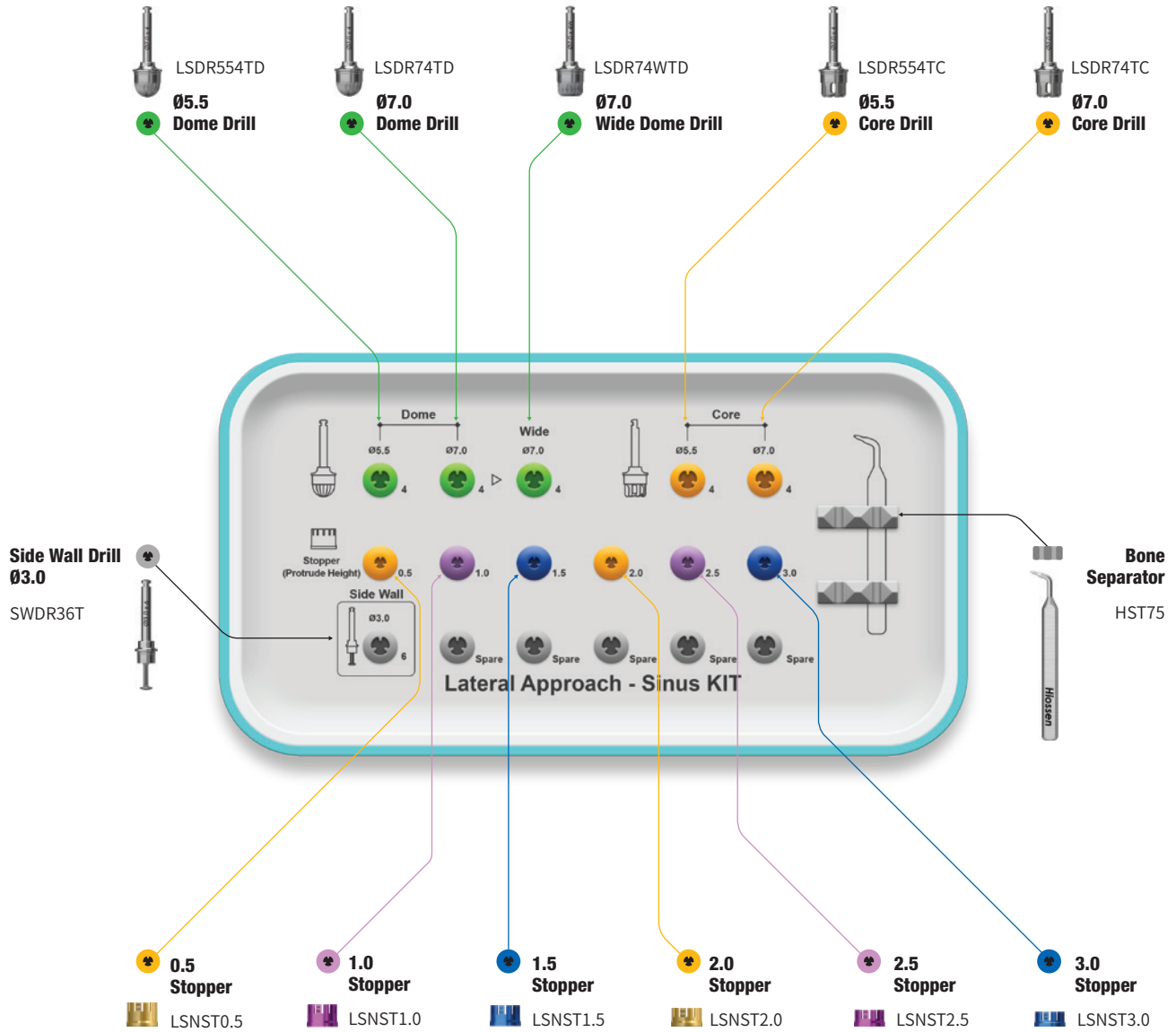

LAS Kit Surgical Kit Instruments

Dome Drill			
Description	D/Ø	Item Code	Image
<ul style="list-style-type: none"> Dome Drill Forms a bone window and collects autogenous bone simultaneously Excellent penetration due to the combination of macro and micro cutting edges Stopper system safely controls the penetration depth Recommended speed: 1,200~1,500rpm Excessive drilling may cause damage to the membrane 	Ø5.5	LSDR554TD	
	Ø7.0	LSDR74TD	
	Wide Ø7.0	LSDR74WTD	

Core Drill			
Description	D/Ø	Item Code	Image
<ul style="list-style-type: none"> Creates a bone lid while forming the lateral window Cutting edge design based on the CAS drill, enhancing safety Recommended speed: 1,200~1,500rpm Excessive drilling may cause damage to the membrane 	Ø5.5	LSDR554TC	
	Ø7.0	LSDR74TC	

Side Wall Drill						
Description	Item Code		Image			
<ul style="list-style-type: none"> Enlarges and trims the rough edges of the bone window Cutting blades start 1 mm above the bottom of the drill Recommended speed: 1,500rpm 	SWDR36T					
	Height of side cutting blade (mm)	1.0	2.0	3.0	4.0	.05
CAS Kit stopper (mm)	8.0	9.0	10	11	12	
Side wall Drill + CAS Kit stopper						
<ul style="list-style-type: none"> Stoppers safely control the drilling depth 						

Bone Separator		
Description	Item Code	Image
<ul style="list-style-type: none"> Removes the bone lid inside the core drill 	HST75	

Side Wall Drill							
Description	Length	0.5	1.0	1.5	2.0	2.5	3.0
<ul style="list-style-type: none"> Laser marked numbers indicate the drilling depth Color-coded by length Can be used up to 50 times before replacement 							
	Item Code	LSNST0.5	LSNST1.0	LSNST1.5	LSNST2.0	LSNST2.5	LSNST2.0
	Color	Yellow	Purple	Blue	Yellow	Purple	Blue

ESSET Kit (HESEK)

For

- EKIII
- ETIII/IV
- SSII/III
- Ultra-Wide

Lower panel components

Torque Wrench
TQWCB



Depth Gauge
ODG

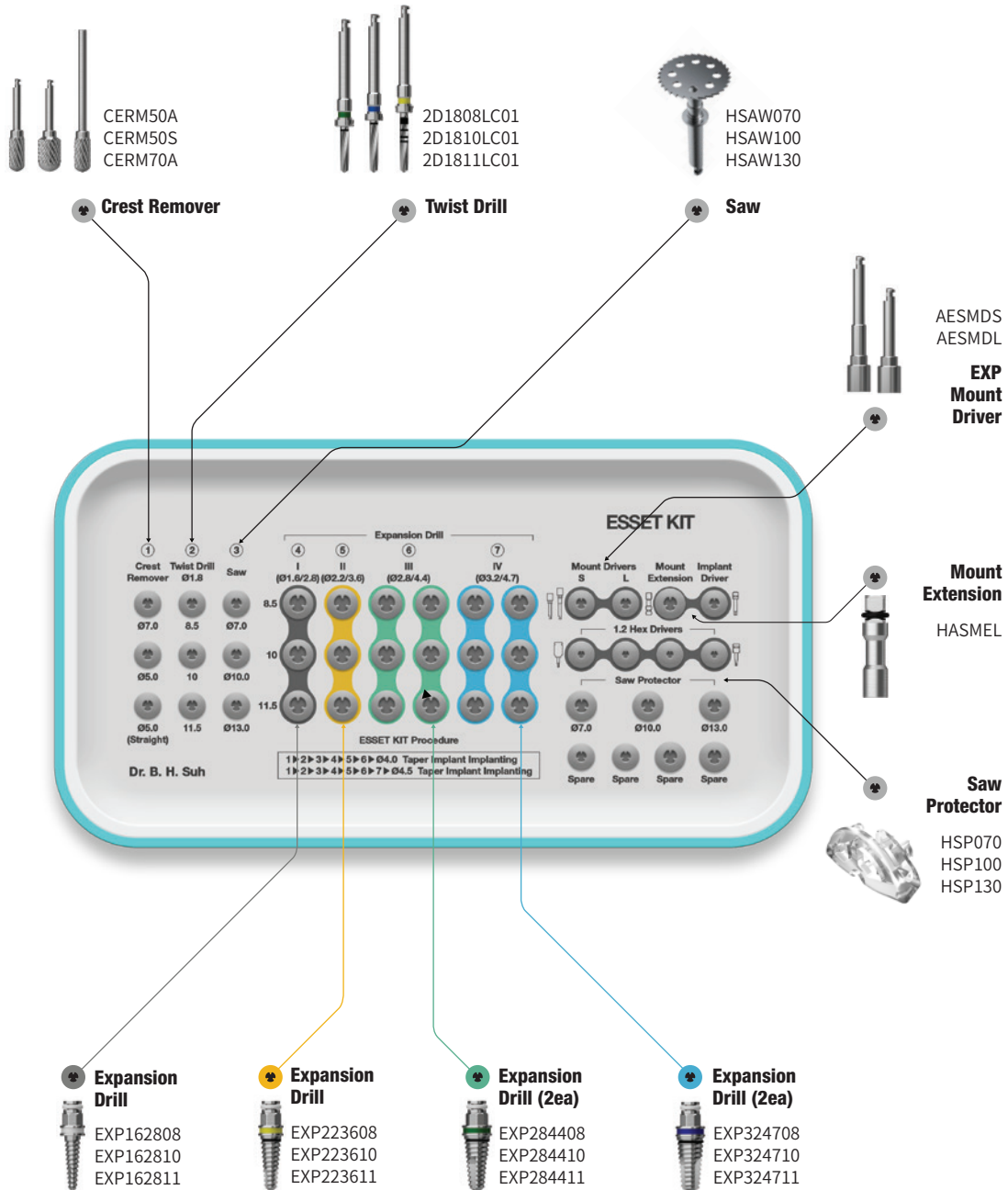

ESSET Kit Surgical Kit Instruments

Crest Remover				
Description	L	Ø5.0	Ø7.0	Image
<ul style="list-style-type: none"> Grinds down narrow alveolar ridge, and creates an indentation for the implant's insertion site Angled type recommended speed: 1,200~1,500rpm Straight type recommended speed: 15,000~30,000rpm 	29	CERM50A	CERM70A	
	45	CERM50S	-	

Twist Drill				
Description	L	TL	Ø1.8	Image
<ul style="list-style-type: none"> Marks the implant's insertion site Controls depth with the built-in stopper Recommended speed: 1,200 ~ 1,500 rpm 	8.5	33	2D1808LC01	
	10	34.5	2D1810LC01	
	11	36	2D1811LC01	

Saw				
Description	T	TL	Item Code	Image
<ul style="list-style-type: none"> For ridge modification and splitting After vertical incision, move from mesial to distal Recommended speed: 1,200 ~ 1,500 rpm Recommended use: 10 times *T = Thickness 	0.3	Ø7.0	HSAW070	
		Ø10	HSAW100	
		Ø13	HSAW130	

Saw Protector				
Description	D	Item Code	Image	
<ul style="list-style-type: none"> Semi-circular saw cover protects user when using saws See through protector for maximum procedure visibility 360° rotary saw cover for flexible operation Material: Plastic <p>※ Single use only (Do not reuse)</p>	Ø7.0	HSP070		
	Ø10	HSP100		
	Ø13	HSP130		

ESSET Kit Surgical Kit Instruments

Expansion Drill					
Description	Type	8.5	10	11.5	Image
<ul style="list-style-type: none"> Gradually expands narrow alveolar ridge Use the Expansion Drills in numerical order based on the diameter of the implant F4.0: I → II → III/F4.5: I → II → III → IV Recommended speed: 25~35rpm 	I Ø1.6/2.8	EXP162808	EXP162810	EXP162811	
	II Ø2.2/3.6	EXP223608	EXP223610	EXP223611	
	III Ø2.8/4.4	EXP284408	EXP284410	EXP284411	
	IV Ø3.2/4.7	EXP324708	EXP324710	EXP324711	

Mount Extension		
Description	Item Code	Image
<ul style="list-style-type: none"> Used to apply manual torque when inserting/removing the Expansion Drills 	HASMEL	

EXP Mount Driver			
Description	Length	Item Code	Image
<ul style="list-style-type: none"> Used to inserting/removing the Expansion Drills with a handpiece and engine 	Short (22.1)	AESMDS	
	Long (28.6)	AESMDL	

Torque Wrench		
Description	Item Code	Image
<ul style="list-style-type: none"> Use to apply torque to the Expansion Drill 	TQWCB	

Depth Gauge		
Description	Item Code	Image
<ul style="list-style-type: none"> Releases excessive torque when hand piece does not move due to being stuck in bone during expansion drill removal process. Use with an open wrench to turn the hex of the Expansion drill Prevents from over torquing 	ODG	

HiOSSEN
IMPLANT

EM Kit (HMISLK)

Lower panel components

Depth Gauge
HMDTGG



Ratchet Wrench
CITQW-1185A

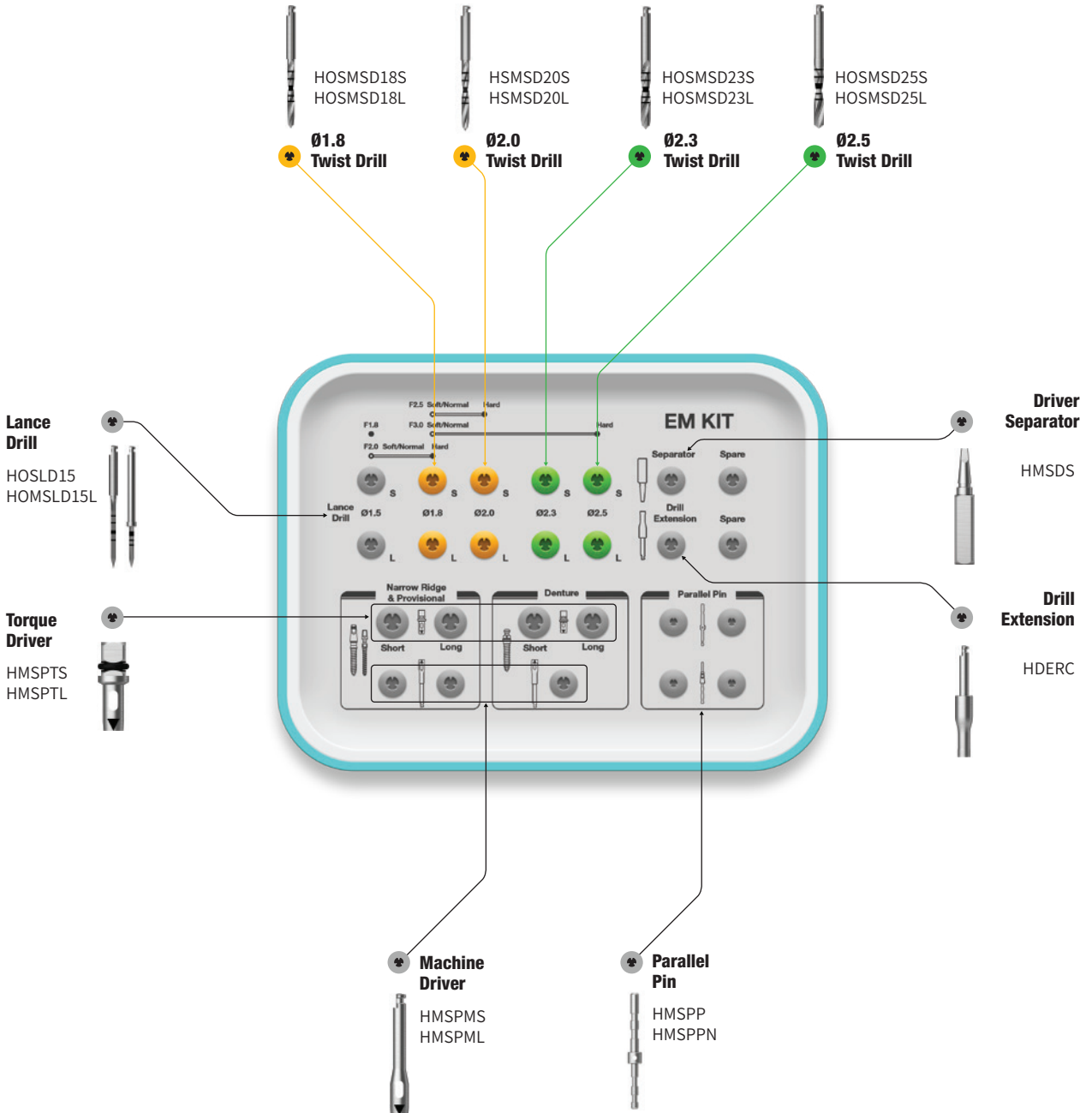

EM Kit Surgical Kit Instruments

Drill for EM Implant							
Description	Length	Ø1.5	Ø1.8	Ø2.0	Ø2.3	Ø2.5	Image
<ul style="list-style-type: none"> Laser markings on drill match implant length specifications (8/10/11.5/13/15 mm) In cortical bone, it is recommended to use the lance drill to drill to the final implant length Long type has a stopper at 13mm 	Short (35)	HOSLB15	-	-	-	-	
	Long (38)	HOMSLD15L	-	-	-	-	
	Short (33)	-	HOSMSD18S	HSMSD20S	HOSMSD23S	HOSMSD25S	
	Long (31)	-	HOSMSD18L	HSMSD20L	HOSMSD23L	HOSMSD25L	

Driver for Narrow Ridge & Provisional Type				
Description		Length	Ø3.4	Image
<ul style="list-style-type: none"> Driver for EM (MS) implants: narrow ridge & provisional The triangular marking is used in line with the implant 	Torque Driver	Short (16.5)	HMSPTS	
		Long (21.5)	HMSPTL	
	Machine Driver	Short (24.4)	HMSPPM	
		Long (29.4)	HMSPLL	

Driver for Denture Type				
Description		Length	Ø3.8	Image
<ul style="list-style-type: none"> Driver for EM (MS) Implant denture The triangular marking should be aligned with the implant 	Torque Driver	Short (13.5)	HMSDTS	
		Long (18.5)	HMSDTL	
	Machine Driver	Long (21.4)	HMSDMS	

Gauge for MS Implant					
Description		Length	Item code	Image	
<ul style="list-style-type: none"> Depth gauge <ul style="list-style-type: none"> Left: to check the drilled depth Right: to bend the neck of the EM (MS) provisional type MS narrow narrow ridge type cannot be bent Parallel pin is used to confirm the path of the implant after drilling <ul style="list-style-type: none"> MSP: lower diameter Ø1.5/upper diameter Ø1.8 MSPN: lower diameter Ø1.5/upper shape is same as the abutment portion of the MS narrow ridge 	Depth Gauge		HMDTGG		
	Parallel Pin			HMSPP	
				HMSPPN	

Torque Driver Handle	
Description	Image/Item code
<ul style="list-style-type: none"> Used for initial insertion by hand after fastening to torque driver 	 HMSTH

Driver Separator	
Description	Image/Item code
<ul style="list-style-type: none"> If the MS implant is jammed in the Driver, the Driver Separator can be leveraged to separate the two 	 HMSDS

MS Removal Tool					
Description	Image				
<ul style="list-style-type: none"> Easy removal of fractured EM Implant (Narrow Ridge) The tool is used by rotating in the reverse direction after assembling to the universal handle Options based on diameter of fractured implant For Ø 2.0, use orthodontic screw removal tool (code: OSRT20E) <p>※ Disposable. Do not reuse</p>					
D/Ø				Ø2.5	Ø3.0
				HMRT25E	HMRT30E

Drilling Sequence EM Drill

Narrow Ridge | Denture | Provisional

(Length: 10mm)

Ø1.8mm

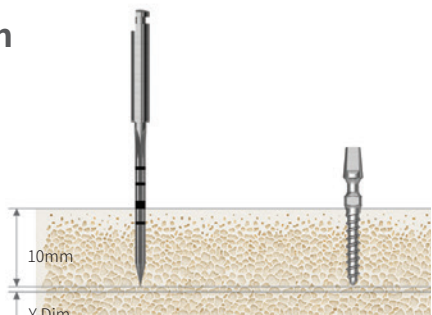

Bone Quality	Lance Drill	Ø1.8 Implant
Soft	▶	Implant Placement
Normal	▶	
Hard	▶	

Ø2.0mm

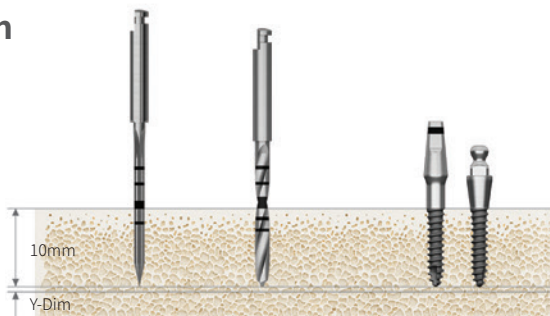

Bone Quality	Lance Drill	Drill (Ø1.8)	Ø2.0 Implant
Soft	▶		Implant Placement
Normal	▶		
Hard	▶	▶	

Ø2.5mm

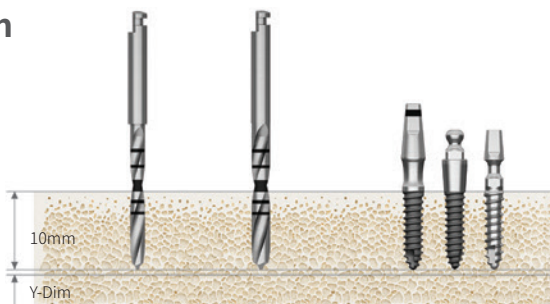



Bone Quality	Drill (Ø1.8)	Drill (Ø2.0)	Ø2.5 Implant
Soft	▶		Implant Placement
Normal	▶		
Hard		▶	

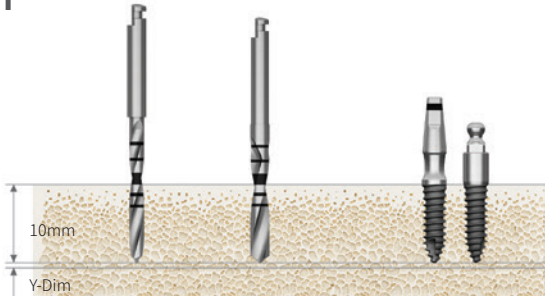



Ø3.0mm





Bone Quality	Drill (Ø1.8)	Drill (Ø2.5)	Ø3.0 Implant
Soft	▶		Implant Placement
Normal	▶		
Hard		▶	

Surgical Instrument

Abutment Positioning Driver				
Description	H + G/H	Length	Item Code	Image
<ul style="list-style-type: none"> Used for assembling the abutment in the prosthetic process after placing an implant ※ For Transfer Abutment only Function to help convenient and stable mounting and tightening of the abutment being pushed away by gingiva Used according to the H and G/H lengths of the abutment to be removed as shown below 	5.0, 6.0, 7.0, 8.0, 9.0	Short (≤9)	HAPDS	
	10, 11, 12, 13, 14	Long (≥10)	HAPDL	

NoMount Torque Driver for ET					
Description	C	Length	Item Code	Image	
<ul style="list-style-type: none"> Directly connects to an ET Implant for placement with a Torque Wrench Ensure correct and complete seating before applying torque; loose connection may cause implant fracture C = Connection 	Mini	Short (19)	HGSNMT32S		
		Long (26.6)	HGSNMT32L		
		Ex. Long (33.6)	HGSNMT32E		
	Regular	Short (19)	HGSNMT35S		
		Long (26.6)	HGSNMT35L		
		Ex. Long (33.6)	HGSNMT35E		

NoMount Torque Driver for SS				
Description	C	Length	Item Code	Image
<ul style="list-style-type: none"> Directly connects to a SS Implant for placement with a Torque Wrench Ensure correct and complete seating before applying torque; loose connection may cause implant fracture C = Connection 	Regular / Wide	Short (16.8)	HSSNMT39S	
		Long (26.8)	HSSNMT39L	

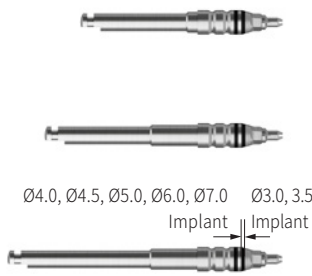
NoMount Driver for EK				
Description	C	Length	Item Code	Image
<ul style="list-style-type: none"> Ø3.5 implant is combined with the bottom of the lower marking Ø4.0, Ø4.5, Ø5.0, Ø6.0 and Ø7.0 implants are combined with the upper part of the lower marking The distance between the two laser marking is 0.5mm C = Connection 	Regular	Short (27.6)	HKSNMDCRS	
		Long (32.6)	HKSNMDCRL	
		Extra Long (37.6)	HKSNMDCRE	

Implant Driver for ET				
Description	C	Length	Item Code	Image
<ul style="list-style-type: none"> Connects directly to an ET implant for final adjustments to the implant's depth C = Connection 	Mini	Short (17)	HGSMFDS	
		Long (24)	GSMFDL	
		Ex. Long (34)	HGSMFDE	
	Regular	Short (19)	HGSRFDS	
		Long (26.6)	GSRFDL	
		Ex. Long (33.6)	HGSRFDE	

Implant Driver for SS				
Description	C	Length	Item Code	Image
<ul style="list-style-type: none"> Connects directly to a SS implant for final adjustments to the implant depth C = Connection 	Regular/ Wide	Short (14)	HSSRFDS	
	Regular/ Wide	Long (24)	SSRFDL	
	Regular/ Wide	Ex. Long (31)	HSSRFDE	

Implant Driver for EK				
Description	C	Length	Item Code	Image
<ul style="list-style-type: none"> Connects directly to an EK implant for final adjustments to the implant's depth C = Connection 	Regular	Short	HKSFDS	
		Long	HKSFDL	

Torque Extension		
Description	Item Code	Image
<ul style="list-style-type: none"> Extends the length of an instrument by 10mm Connects to the torque wrench 	HOTE	

Surgical Instrument Kit

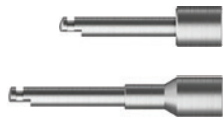
Simple Mount Driver			
Description	Length	Item Code	Image
<ul style="list-style-type: none"> Connects to mounted implants for placement For use with a handpiece/implant motor 	Short (20.1)	HASMDS	
	Long (26.5)	HASMDL	

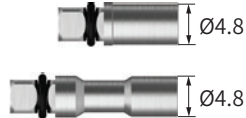
Simple Mount Extension			
Description	Length	Item Code	Image
<ul style="list-style-type: none"> Extends the length of the simple mount driver and converts it for use with the Torque Wrench 	Short (14.5)	HASMES	
	Long (20.5)	HASMEL	

Simple Open Wrench		
Description	Item Code	Image
<ul style="list-style-type: none"> Disengages the simple mount when bone quality is poor Easy insertion into the mouth with a neck angle of 30° 	SPOW	

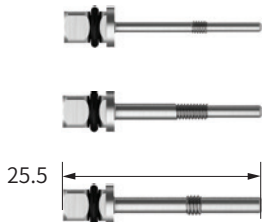
Removal Tool for Implant Mount			
Description	Application	Item Code	Image
<ul style="list-style-type: none"> Removes the mount if the mount becomes wedged in the implant Used with Driver Handle or Torque Wrench Removes the mount screw, insert the Removal Tool into the mount, and turn clockwise App = Application 	Mini (ET,US)	HERFM	
	Regular (ET,US) Wide (SS)	HHRFR	
	Wide (US)	HERFW	

Depth Gauge		
Description	Item Code	Image
<ul style="list-style-type: none"> Measures drilling depth (7~15mm) 	ODG	

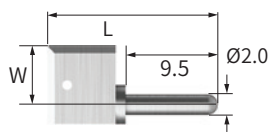
Positioning Guide			
Description	W/L	Item Code	Image
<ul style="list-style-type: none"> Help set the drilling interval for implant insertion Insert after initial drilling 	2.5 / 21.5	HAPG201	
	6.0 / 17.5	HAPG202	
	11 / 17.5	HAPG203	

Tissue Height Gauge for ET		
Description	Item Code	Image
<ul style="list-style-type: none"> Connects to the ET implant to measure the height of the gingiva in relation to the implant 	HGTSHG	 A long, thin metal gauge with two curved ends. The central part has markings: '1238458788 M OSSTEM IMPLANT S 8878541321'.

Ratchet Wrench		
Description	Item Code	Image
<ul style="list-style-type: none"> It prevents wrench from backdriving Excessive torquing may cause damage to the bone or the inside of a implant 	CITQW-1185A	 A ratchet wrench with a circular head and a long handle. The handle has 'OSSTEM IMPLANT' printed on it.

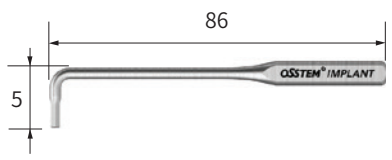
L-Wrench		
Description	Item Code	Image
<ul style="list-style-type: none"> 1.2 hex driver for hard to reach areas like narrow intermaxillary areas Torque indication: when the wrench starts to bend (around 10°), it is possible to apply 5~8Ncm of torque 	HLWC	 An L-shaped wrench with a long handle and a short, angled driver end. Dimensions are shown: 86 for the handle length and 5 for the driver length. The handle has 'OSSTEM IMPLANT' printed on it.

Torque Wrench - Bar Type		
Description	Item Code	Image
<ul style="list-style-type: none"> Adjusts the implant depth, and tightens abutments, screws, etc. Pull the bar back until the desired torque value is reached 	TQWCB	 A torque wrench with a circular head, a long bar, and a handle with a sliding mechanism. The bar has 'OSSTEM IMPLANT' printed on it.

Torque Wrench - Spring Type		
Description	Item Code	Image
<ul style="list-style-type: none"> Applies a precise amount of torque (10/20/30Ncm) to the screw and abutment The neck of the torque wrench will bend when the exact amount of torque has been delivered Do not continue to torque after the neck has bent; excessive force may cause screw fracture etc. 	HTW30	 A torque wrench with a circular head, a long handle with a spring mechanism, and a hexagonal driver end. The handle has 'OSSTEM IMPLANT' printed on it.

Surgical Instrument Kit

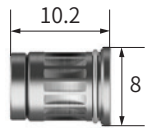
Torque Connector		
Description	Item Code	Image
<ul style="list-style-type: none"> • Tool used convert a square driver connection to a bi-directional connection for the torque wrench 	HRC	

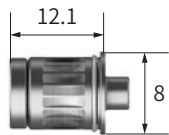
Machine Driver Connector		
Description	Item Code	Image
<ul style="list-style-type: none"> • Tool used convert a machine driver into a bi-directional connection for the torque wrench 	HMDC	

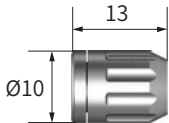
Driver Handle		
Description	Item Code	Image
<ul style="list-style-type: none"> • Connects to the Torque Driver 	HTIDHC	

Machine Driver Handle		
Description	Item Code	Image/Guide
<ul style="list-style-type: none"> • Tool used convert engine type surgical tools into a manual type 	HMDH	

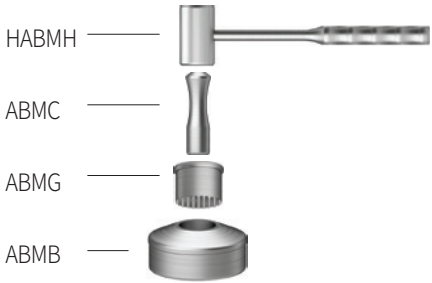
Bone Mill		
Description	Item Code	Image
<ul style="list-style-type: none"> • Grinds harvested autogenous bone 	HABM	

Anterior Hand Driver for Implant

Description	Item Code	Image
<ul style="list-style-type: none"> Manually torque implants in the anterior area Connect to a NoMount torque driver or a implant driver Excessive torque may cause damage to the implant and/or driver 	HAHDI	

Torque Handle











Description	Item Code	Image
<ul style="list-style-type: none"> Connectable to a contra-angle handpiece (Hand-Piece gear ratio to 1:1) Used to connect healing abutments, cover screws, abutment screws, orthodontic screws, etc. (Note: after connecting, make sure that it is tightened with a torque wrench) Excessive torque may cause damage to the screw and/or hand piece 	HTQHD	

HIOSSEN
IMPLANT

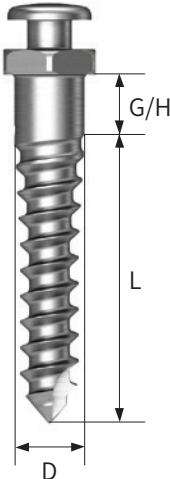
ORTHODONTIC SYSTEM

OrthAnchor Simple Head	234
OrthAnchor Through Hole	235
OrthAnchor Small Head	236
OrthAnchor Bracket Head	237
OrthAnchor Simple Head Half Etched	238
OrthAnchor Through Hole Half Etched	239
Ortho KIT	240

OrthAnchor Simple Head

Simple Head						
Description					Guide	
<ul style="list-style-type: none"> Machined surface Material : Ti-6Al-4V No through-hole Fixation Components: coil spring ($\varnothing 2.5$), power chain, elastic band <p>※ G/H 4.0 Type is a Make-to-Order Product</p>						
D	$\varnothing 1.2$			$\varnothing 1.4$		
G/H	6	8	10	6	8	10
L						
1.5	OSSH1206	OSSH1208	-	OSSH1406	OSSH1408	-
4.0	-	-	-	-	-	-
D	$\varnothing 1.6$			$\varnothing 1.8$		
G/H	6	8	10	6	8	10
L						
1.5	OSSH1606	OSSH1608	OSSH1610	OSSH1806	OSSH1808	OSSH1810
4.0	OSSH16064	-	-	OSSH18064	-	-

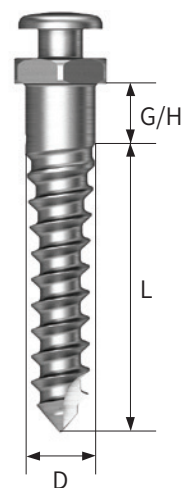





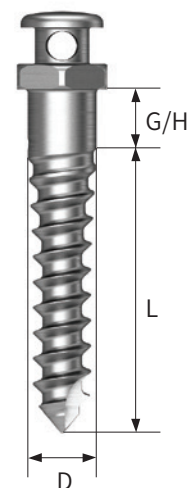



OrthAnchor Through Hole

Through Hole							Guide
Description							
<ul style="list-style-type: none"> Machined surface Material : Ti-6Al-4V No through-hole Fixation Components: coil spring (Ø2.5), power chain, elastic band <p>※ G/H 4.0 Type is a Make-to-Order Product</p>							
D	Ø1.2			Ø1.4			
G/H	6	8	10	6	8	10	
L							
1.5	OSTH1206	OSTH1208	-	OSTH1406	OSTH1408	-	
4.0	-	-	-	-	-	-	
D	Ø1.6			Ø1.8			
G/H	6	8	10	6	8	10	
L							
1.5	OSTH1606	OSTH1608	OSTH1610	OSTH1806	OSTH1808	OSTH1810	
4.0	OSTH16064	-	-	OSTH18064	-	-	







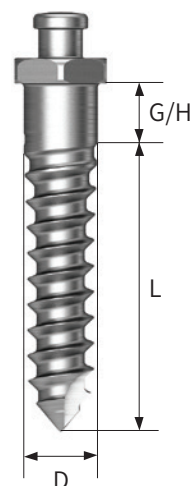

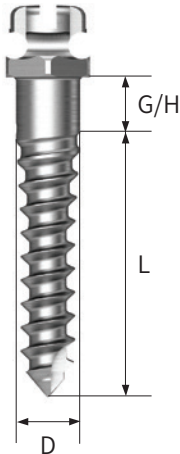

OrthAnchor Small Head

Small Head						
Description				Guide		
<ul style="list-style-type: none"> Machined surface Material : Ti-6Al-4V Head diameter: Ø1.48 mm Fixation Components: coil spring (Ø1.5/2.0/2.5), power chain, elastic band 						
D	Ø1.2			Ø1.4		
G/H	6	8	10	6	8	10
L						
1.5	-	-	-	OSSH1406	OSSH1408	-
4.0	-	-	-	-	-	-
D	Ø1.6			Ø1.8		
G/H	6	8	10	6	8	10
L						
1.5	OSSH1606	OSSH1608	OSSH1610	OSSH1806	OSSH1808	OSSH1810
4.0	-	-	-	-	-	-







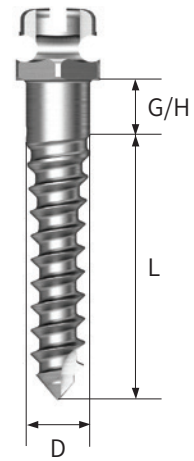





OrthAnchor Bracket Head

Bracket Head							Guide
Description							
<ul style="list-style-type: none"> Machined surface Material : Ti-6Al-4V Excellent compatibility with various archwires Easy path adjustment using the cross wire slot Fixation Components: arch wire (rec./round), coil spring (Ø2.5), power chain, elastic band 							
D	Ø1.2			Ø1.4			
G/H	6	8	10	6	8	10	
L							
1.5	-	-	-	OSBH1406	OSBH1408	-	
4.0	-	-	-	-	-	-	
D	Ø1.6			Ø1.8			
G/H	6	8	10	6	8	10	
L							
1.5	OSBH1606	OSBH1608	OSBH1610	OSBH1806	OSBH1808	OSBH1810	
4.0	-	-	-	-	-	-	







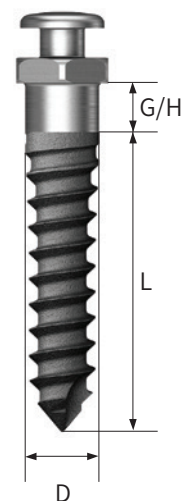



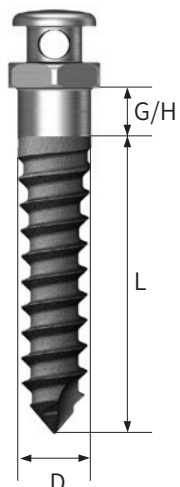

OrthAnchor Simple Head Half Etched

Simple Head Half Etched							Guide
Description							
<ul style="list-style-type: none"> • Acid etched surface • Material : Ti-6Al-4V • Minimization of early detachment possibility • Minimizes the risk of early detachment • Provides stable results when applied in pediatric/adolescent patients or cases with poor bone quality • Fixation Components: arch wire (round), coil spring (Ø2.5), power chain, elastic band 							
D	Ø1.2			Ø1.4			
G/H	6	8	10	6	8	10	
L							
1.5	OSSH1206HE	OSSH1208HE	-	OSSH1406HE	OSSH1408HE	-	
D	Ø1.6			Ø1.8			
G/H	6	8	10	6	8	10	
L							
1.5	OSSH1606HE	OSSH1608HE	OSSH1610HE	OSSH1806HE	OSSH1808HE	OSSH1810HE	



OrthAnchor Through Hole Half Etched

Through Hole Half Etched							Guide
Description							
<ul style="list-style-type: none"> • Acid etched surface • Material : Ti-6Al-4V • Minimization of early detachment possibility • Minimizes the risk of early detachment • Provides stable results when applied in pediatric/adolescent patients or cases with poor bone quality • Fixation Components: arch wire (round), coil spring (Ø2.5), power chain, elastic band 							
D	Ø1.2			Ø1.4			
G/H	6	8	10	6	8	10	
L							
1.5	OSSH1206HE	OSSH1208HE	-	OSSH1406HE	OSSH1408HE	-	
D	Ø1.6			Ø1.8			
G/H	6	8	10	6	8	10	
L							
1.5	OSSH1606HE	OSSH1608HE	OSSH1610HE	OSSH1806HE	OSSH1808HE	OSSH1810HE	

Orth Kit (OOKS)

Applicable Products OS

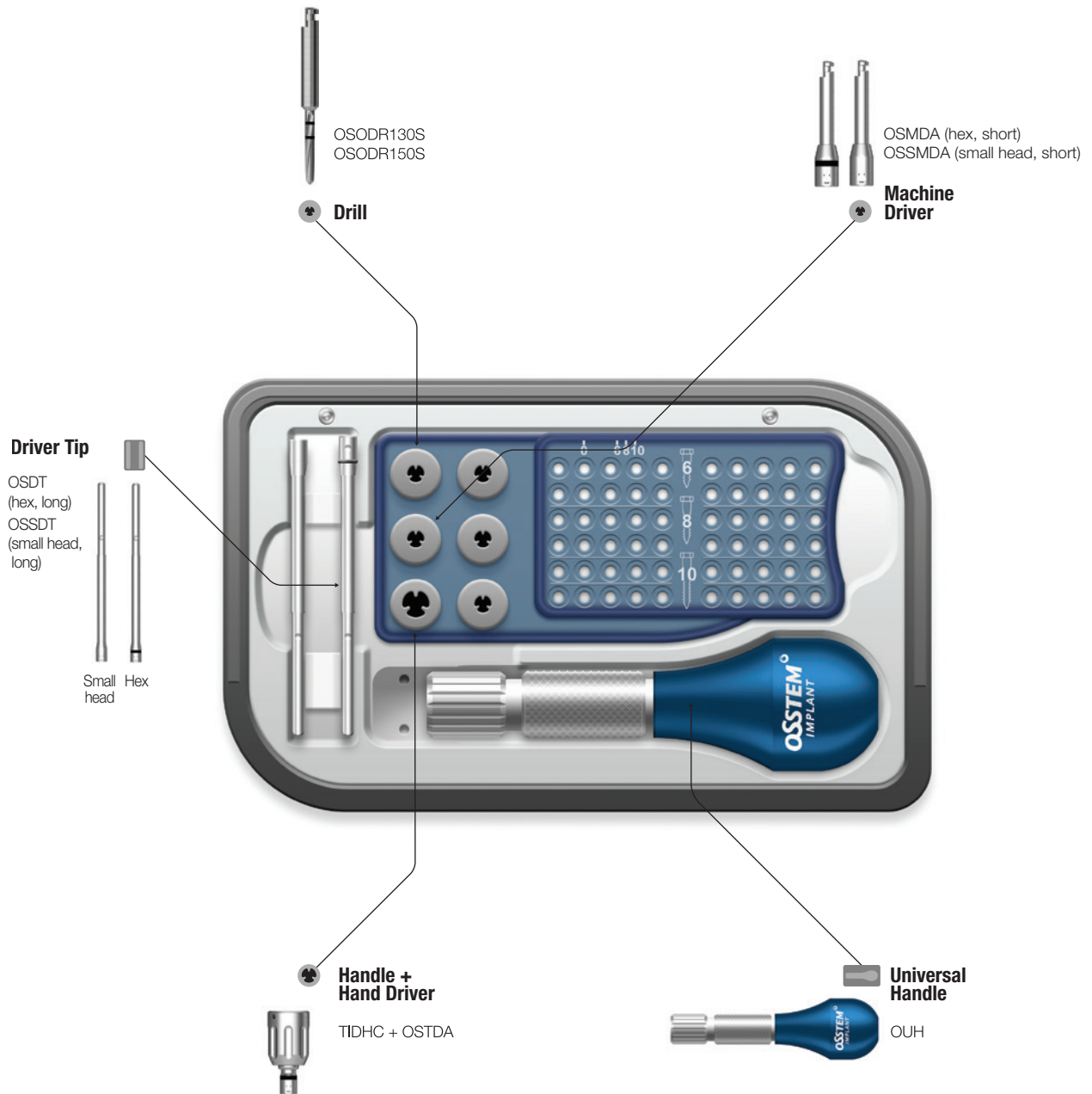

Orth Kit Surgical Instruments

Drill					
Description		Image/Guide			
<ul style="list-style-type: none"> • Connect to handpiece (engine) for use • Ø1.0 drill: For Ø1.2 / 1.4 screws • Ø1.3 drill: For Ø1.6 screws • Ø1.5 drill: For Ø1.8 screws • Recommended speed: 800 rpm (high speed) • Recommended to drill cortical bone only before implantation (For very thick cortical bone, drill to the same length as the screw) • Ø1.0 drill is sold separately (not included in the kit) 					
D	L			Short	Long
Ø1.0				OSODR100S	-
Ø1.3				OSODR130S	OSODR130C
Ø1.5		OSODR150S	OSODR150C		



Universal Handle		
Description	Item Code	Image
<ul style="list-style-type: none"> • Used after connecting to the driver tip • Features an anti-slip handle for easy handling 	OUH	

Driver Tip				
Description	Type	Short	Long	Image
<ul style="list-style-type: none"> • Connects to a universal handle for OrthAnchor placement • Available types: standard hex driver and small-head driver 	Hex	OSDTS (45)	OSDT (67)	
	Small Head	OSSDTS (45)	OSSDT (67)	

Surgical Instrument Kit

Hand Drill		
Description	Item Code	Image
<ul style="list-style-type: none"> Connects to the Universal Handle for use Designed for cortical bone removal only Drilling depth: 4 mm Sold separately (not included in the kit) <p>※ Keep the drill aligned to avoid bending stress during use</p>	OSHDR130	

Driver Handle		
Description	Item Code	Image
<ul style="list-style-type: none"> Used for manual tightening of screws after connecting to the hand driver 	HTIDHC	

Hand Driver			
Description	Type	Item code	Image
<ul style="list-style-type: none"> Connects to a driver handle or ratchet wrench for OrthAnchor screw placement Available types: standard hex driver and small-head hand driver Small-head hand driver sold separately (not included in the kit) 	Hex	OSTDA	
	Small Head	OSSTDA	

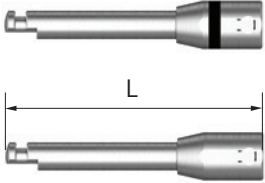
Machine Driver				
Description	Type	Short	Long	Image
<ul style="list-style-type: none"> Connects to the engine for OrthAnchor placement Available types: standard hex driver and small-head machine driver 	Hex	OSMDA (21.4)	OSMDB (31.4)	
	Small Head	OSSMDA (21.4)	OSSMDB (31.4)	

HIOSSEN
IMPLANT

HIOSSEN
IMPLANT

GBR & DENTAL MATERIAL

XENOGRAFT BONE

A-Graft 246

ALLOGRAFT BONE

SurFuse™ / ExFuse™ 246

SureOss™ / SureOss™-D / OsteOss™ 247

CANOSS™ / INGROSS™ / H-OSS™ 248

Omni Oss® 249

ExOss™ / ExOss™ Plus 250

SureGenix 251

ABSORBABLE MEMBRANE

SureDerm™ / D-Sure™ Block 252

OssGuide / Cytoplast® RTM Collagen
/ Synthetic Bone (Alloplast) 253

NON-ABSORBABLE MEMBRANE

Cytoplast® TXT-200 / Cytoplast® TI-150 254

Cytoplast® TI-250 255

ABSORBABLE WOUND DRESSING

Cytoplast® RTM Plug / Foam / Tape 256

Zcore™ Expand / Form 257

BONE REGENERATION SOLUTIONS

OssBuilder Type & Components 258

OssBuilder Kit & Components 264

GBR Kit & components 268

DENTAL MATERIAL

HySil Plus 272

Impression Accessories 273

SUTURE

NON-ABSORBABLE

UNIFY® - Nylon / PTFE 274

Cytoplast - PTFE 275

ABSORBABLE

UNIFY® - PDO / PGCL 276

UNIFY® - Premium Chromic Gut 277

Glycolon Resorba 278

PGA Resorba 279

Xenograft Bone



A-Graft					
Description	g	P	0.25~1.0mm (Small)	Image	
<ul style="list-style-type: none"> • DBB (Deproteinized Bovine Bone) • Osteoconductive properties • Great volume stability • Excellent Biocompatibility • Raw materials: USA • Manufacturer: Hiossen, Inc • P = Particle size 	0.1	(0.2cc)	HAS010SV		
	0.25	(0.5cc)	HAS025SV		
	0.5	(1.0cc)	HAS050SV		
	1.0	(2.0cc)	HAS100SV		
	2.0	(4.0cc)	HAS200SV		
	g	P	1.0~2.0mm (Large)		
	0.1	(0.3cc)	HAS010LV		
	0.25	(0.75cc)	HAS025LV		
	0.5	(1.5cc)	HAS050LV		
	1.0	(3.0cc)	HAS100LV		
	2.0	(6.0cc)	HAS200LV		

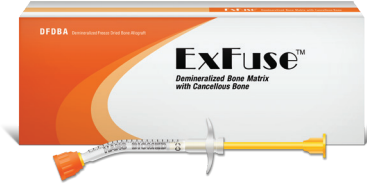

Allograft Bone DBM Putty



SurFuse™			
Description	CC	Putty	Image
<ul style="list-style-type: none"> • DFDBA (Deminerlized Cortical Bone) with CMC (Carboxymethylcellulose) Carrier • Osteoconductive and Osteoinductive properties • Syringe Delivery • Excellent biocompatibility • Premixed, ready to use, and easy to shape and mold as needed • Particle size: 200~850 µm • Composition: 30% DFDBA Cortical, 70% CMC • Shelf life: 2 years stored in room temperature • Manufacturer: HansBiomed Corp 	0.3	SP03	
	0.5	SP05	
	1.0	SP1	

ExFuse™			
Description	CC	Putty	Image
<ul style="list-style-type: none"> • DFDBA (Deminerlized Cortical Bone) with Cancellous Bone & CMC Carrier • Osteoconductive and osteoinductive properties • Syringe delivery • Excellent biocompatibility • Premixed, ready to use, and easy to shape and mold as needed • Particle size: 200~850 µm • Composition: 20% DFDBA Cortical, 10% FDBA Cancellous and 70% CMC • Shelf life: 2 years stored in room temperature • Manufacturer: HansBiomed Corp 	0.3	EP03	
	0.5	EP05	
	1.0	EP1	



Allograft Bone Powder/Chip



SureOss® (FDBA)			
Description	Chips		Image
<ul style="list-style-type: none"> FDBA (Mineralized Freeze-dried Bone Allograft) 100% Cortical Allograft Bone Excellent biocompatibility Osteoconductive and Osteoinductive properties Curved syringe type Shelf life: 5 years stored at room temperature Manufacturer: HansBiomed Corp <p>* 1.0 cc (0.5 cc x 2 per box)</p>	CC	850-1500 µm	
	0.25	SOC25	
	0.5	SOC50	
	*1.0	SOC100	
	Powder		
	CC	200~850 µm	
	0.25	SOP25	
	0.5	SOP50	
	*1.0	SOP100	

SureOss®-D (DFDBA)			
Description	Chips		Image
<ul style="list-style-type: none"> DFDBA (Deminerlized Freeze-dried Bone Allograft) 100% Cortical Allograft Bone Excellent biocompatibility Osteoinductive properties Curved syringe type Shelf life: 5 years stored at room temperature Manufacturer: HansBiomed Corp. <p>* 1.0 cc (0.5 cc x 2 per box)</p>	CC	850-1500 µm	
	0.25	DSOC25	
	0.5	DSOC50	
	*1.0	DSOC100	
	Powder		
	CC	200~850 µm	
	0.25	DSOP25	
	0.5	DSOP50	
	*1.0	DSOP100	

OsteOss™ (FDBA)			
Description	Chips		Image
<ul style="list-style-type: none"> FDBA (Mineralized Freeze-dried Bone Allograft) 50% Cortical, 50% Cancellous Bone Excellent biocompatibility Great Osteoconductive and Osteoinductive properties Curved syringe type Shelf life: 5 years stored at room temperature Manufacturer: HansBiomed Corp. <p>* 1.0 cc (0.5 cc x 2 per box)</p>	CC	850-1500 µm	
	0.25	CCC025	
	0.5	CCC050	
	*1.0	CCC100	
	Powder		
	CC	200~850 µm	
	0.25	CCP025	
	0.5	CCP050	
	*1.0	CCP100	



Allograft Bone Powder/Chip

CANOSS™ (FDBA)				
Description	Chips		Image	
<ul style="list-style-type: none"> • FDBA (Mineralized Freeze-dried Bone Allograft) • 100% Cancellous Allograft • Osteoinduction/Osteoconduction • Syringe delivery • Excellent biocompatibility • Easy handling • Manufacturer: HanBiomed Corp 	CC	850-1500 µm		
	0.25	CAC025		
	0.5	CAC050		
	1.0	CAC100		
	Powder			
	CC	200~850 µm		
	0.25	CAP025		
	0.5	CAP050		
	1.0	CAP100		



INGROSS™ (DFDBA+FDBA)				
Description	Chips		Image	
<ul style="list-style-type: none"> • DFDBA (Deminerlized Freeze-dried Bone Allograft) • 100% Cortical Bone • (70% Mineralized and 30% Deminerlized Cortical Bone) • Osteoinduction/Osteoconduction • Syringe delivery • Excellent biocompatibility • Easy handling • Manufacturer: HanBiomed Corp 	CC	850-1500 µm		
	0.25	CDC025		
	0.5	CDC050		
	1.0	CDC100		
	Powder			
	CC	200~850 µm		
	0.25	CDP025		
	0.5	CDP050		
	1.0	CDP100		



H-Oss™ (FDBA)			
Description	Powder		Image
<ul style="list-style-type: none"> • FDBA (Mineralized Freeze-dried Bone Allograft) • 70% Cortical and 30% Cancellous Bone • Curved syringe type • Excellent biocompatibility • Osteoconductive and Osteoinductive properties • Shelf life: 5 years stored at room temperature • Manufacturer: HanBiomed Corp 	CC	200~850 µm	
	0.25	HCCP025	
	0.5	HCCP050	
	1.0	HCCP100	

Allograft Bone Powder/Chip



Omni Oss® (FDBA)					
Description	100% Cortical			Image	
<ul style="list-style-type: none"> FDBA (Mineralized Freeze-dried Bone Allograft) 100% Cortical Bone 70% Cortical and 30% Cancellous Bone 50% Cortical and 50% Cancellous Bone Syringe Delivery Osteoconductive and Osteoinductive properties Shelf Life: 5 years stored at room temperature Manufacturer: KMLbio <p>* 1.0 cc (0.5 cc x 2 per box)</p>	CC	Chips 0.71 – 1.6 mm	Powder 0.25 – 0.71 mm	 <p>Omni Oss®</p>	
	0.3	OSC030	OS030		
	0.5	OSC050	OS050		
	1.0	OSC100	OS100		
	70% Cortical / 30% Cancellous				 <p>Omni Oss® Plus A</p>
	CC	Chips 0.71 – 1.6 mm	Powder 0.25 – 0.71 mm		
	0.3	OSPC030A	OSP030A		
	0.5	OSPC050A	OSP050A		
	1.0	OSPC100A	OSP100A		
	50% Cortical / 50% Cancellous				 <p>Omni Oss® Plus B</p>
	CC	Chips 0.71 – 1.6 mm	Powder 0.25 – 0.71 mm		
	0.3	OSPC030B	OSP030B		
	0.5	OSPC050B	OSP050B		
1.0	OSPC100B	OSP100B			

Allograft Bone Powder/Chip

ExOss® (FDBA)				
Description	Chips		Image	
	<ul style="list-style-type: none"> • FDBA (Mineralized freeze-dried bone allograft) • 100% Cortical bone • Osteoconduction/Osteoinduction • Excellent biocompatibility • Vial type • Shelf life: 5 years stored at room temperature • Manufacturer: HansBiomed Corp 	CC		850-1500 µm
0.25		EOSOC025		
0.5		EOSOC050		
1.0		EOSOC100		
2.0		EOSOC200		
5.0		EOSOC500		
		Powder		
CC		200~850 µm		
0.25		EOSOP025		
0.5		EOSOP050		
1.0		EOSOP100		
5.0		EOSOP500		

ExOss™ Plus (FDBA)				
Description	Chips		Image	
	<ul style="list-style-type: none"> • FDBA (Mineralized freeze-dried bone allograft) • 50% Cortical / 50% Cancellous Bone • Osteoconduction/Osteoinduction • Excellent biocompatibility • Vial type • Shelf life: 5 years stored at room temperature • Manufacturer: HansBiomed Corp 	CC		850-1500 µm
0.25		EOCCC025		
0.5		EOCCC050		
1.0		EOCCC100		
2.0		EOCCC200		
5.0		EOCCC500		
		Powder		
CC		200~850 µm		
0.25		EOCCP025		
0.5		EOCCP050		
1.0		EOCCP100		
5.0		EOCCP500		

Allograft Bone Powder/Chip

SureGenix (FDBA)				
Description	50% Cortical/50% Cancellous		Image	
<ul style="list-style-type: none"> FDBA (Mineralized allograft Bone) 100% Cortical Bone 100% Cancellous Bone 50% Cortical/50% Cancellous Bone Vial Type Manufacturer: Allotech for Hiossen ※ 5.0 cc contains 2 x 2.5 cc vials 	CC	Chips 850~1500µm	Powder 200~850µm	
	0.25	SGCCC025	SGCCP025	
	0.5	SGCCC050	SGCCP050	
	1.0	SGCCC100	SGCCP100	
	2.5	SGCCC250	SGCCP250	
	5.0	SGCCC500	SGCCP500	
	100% Cortical			
	CC	Chips 850~1500µm	Powder 200~850µm	
	0.25	SGCOC025	SGCOP025	
	0.5	SGCOC050	SGCOP050	
	1.0	SGCOC100	SGCOP100	
	2.5	SGCOC250	SGCOP250	
	5.0	SGCOC500	SGCOP500	
	100% Cancellous			
	CC	Chips 850~1500µm	Powder 200~850µm	
	0.25	SGCAC025	SGCAP025	
	0.5	SGCAC050	SGCAP050	
	1.0	SGCAC100	SGCAP100	
	2.5	SGCAC250	SGCAP250	
	5.0	SGCAC500	SGCAP500	

Absorbable Membrane Acellular Dermal Matrix

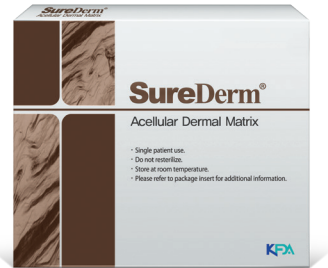
SureDerm® ADM			
Description	Size	Thickness	Image
<ul style="list-style-type: none"> • ADM (Acellular Dermal Matrix) • Derived from Human Dermis • Promotes membrane and gingival tissue reconstruction • Recommend at least 10 minutes' rehydration before application • Excellent biocompatibility • Shelf life: 3 years stored at room temperature • Manufacturer: HanBiomed Corp 	mm	0.18 ~ 0.6 mm	
	10 X 20	D01BX0102	
	10 X 40	D01BX0104	
	20 X 20	D01BX0202	
	20 X 40	D01BX0204	
	mm	0.4 ~ 1.0 mm	
	10 X 20	D04BX0102	
	10 X 40	D04BX0104	
	20 X 20	D04BX0202	
	20 X 40	D04BX0204	
	mm	0.9 ~ 1.6 mm	
	10 X 20	D09DX0102	
	10 X 40	D09DX0104	
	20 X 20	D09DX0202	
	20 X 40	D09DX0204	

Allograft Bone Block			
Description	mm	Item code	Image
<ul style="list-style-type: none"> • DFDBA (Deminerilized Freeze-Dried Bone) • 100% Cancellous Bone Block • Excellent biocompatibility • Osteoinductive and osteoconductive properties • 3D lattice structure promotes rapid revascularization • Open trabecular architecture mimics natural bone • Provides an optimal scaffold for filling larger defects • Available in 3 sizes • Shelf life: 5 years stored at room temperature • Manufacturer: HanBiomed Corp 	10X10X10	GSB10	
	12X12X12	GSB12	
	14X14X14	GSB14	



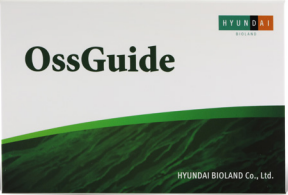

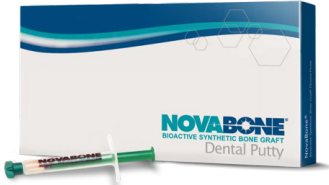

Absorbable Membrane Collagen







OssGuide			
Description	Size	Thickness	Image
<ul style="list-style-type: none"> • Porcine Pericardium Collagen • Resorption time: 3-4 months • Rapid hydration for immediate use • Excellent tensile strength for reliable handling • Enhanced tear resistance for durable performance • Packing Unit: 1/Box • Shelf life: 3 years stored at room temperature • Manufacturer: Hyundai Bioland, Co, Ltd 	mm	0.3 mm	
	15 X 20	TG-1	
	20 X 30	TG-2	
	30 X 40	TG-3	

Cytoplast® RTM Collagen			
Description	Size	Thickness	Image
<ul style="list-style-type: none"> • Bovine Collagen Membrane • RTM (Resorbable Tissue Matrix) • Long-lasting collagen membrane with a resorption profile of 26-38 weeks • Easily drapes over the ridge for optimal coverage • High tensile strength for secure stabilization • Multi-layer construction for enhanced performance • Cell-occlusive design to support tissue regeneration • Packing Unit: 2ea/box • Shelf life: 5 years stored at room temperature • Manufacturer: Osteogenics, USA 	mm	0.3 mm	
	15 X 20	RTM1520	
	20 X 30	RTM2030	
	30 X 40	RTM3040	









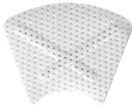

Synthetic Bone (Alloplast)			
Description	CC	Item code	Image
<ul style="list-style-type: none"> • 100% Synthetic, Resorbable Putty • Composed of Calcium Phosphosilicate (CPS) combined with polyethylene glycol and glycerin binder. • The binder enhances handling and helps maintain interparticle spacing, promoting revascularization after implantation. • Ready-to-use, pre-mixed, cohesive, moldable, and fully adaptable to the defect site. • Resorption Time: 10 ~ 12 months • Shelf life: 4 years stored at room temperature • Manufacturer: NovaBone 	0.5	NA1610	
	1.0	NA1611	
	2.0	NA1612	

Non-Absorbable Membrane

Cytoplast® TXT-200			
Description	mm	Single	Image
<ul style="list-style-type: none"> • Non resorbable high-density PTFE membrane • Porosity: less than 0.3 microns • Designed to withstand exposure • Regentex surface is designed to increase surface area available for soft tissue attachment • Bacteria size: 2 ~ 5 µm • Manufacturer: Osteogenics, USA <p>※ TXT1224: 10 membranes/Box ※ TXT1230: 10 membranes/Box ※ TXT2530: 4 membranes/Box</p>	12 X 24	 TXT1224	
	12 X 30	 TXT1230	
	25 X 30	 TXT2530	

Cytoplast® TI-150			
Description	mm	TI-150	Image
<ul style="list-style-type: none"> • Titanium-Reinforced Non-Resorbable Membrane • High-density PTFE membrane • Easily molded and shaped for tenting and space maintenance • Titanium frame can be trimmed and shaped to create additional space for bone regeneration • Regentex™ surface enhances surface area for improved soft tissue attachment • Thickness: 150 µm • Manufacturer: Osteogenics, USA 	14 X 24	 Anterior Single TI150AS-1	
	12 X 24	 Anterior Narrow Double TI150ANL-2	
	20 X 25	 Posterior Single TI150PS-1	

Non-Absorbable Membrane

Cytoplast® TI-250			
Description	mm	Ti-250	Image
<ul style="list-style-type: none"> • Non-Resorbable High-Density PTFE Membrane • Ideal for ridge augmentation and grafting of bony defects missing one or more walls • Easily molded and shaped for tenting and space maintenance • Titanium frame can be trimmed and shaped to create additional space for bone regeneration • Regentex™ surface enhances surface area for improved soft tissue attachment • Thickness: 250 µm • Manufacturer: Osteogenics 	12x24	 Anterior Narrow Single TI250ANL-1 Anterior Narrow Double TI250ANL-2	
	13 X 19	 Anterior Perio Single TI250AP-1 Anterior Perio Double TI250AP-2	
	14x24	 Anterior Single TI250AS-1 Anterior Double TI250AS-2	
	20x25	 Posterior Single: TI250PS-1 Posterior Double: TI250PS-2	
	25 X 30	 Posterior Large Single TI250PL-1 Posterior Large Double TI250PL-2	

Absorbable Wound Dressing Collagen

Cytoplast® RTM Plug			
Description	mm		Image
<ul style="list-style-type: none"> Resorbable Collagen Scaffold Soft, sponge-like matrix ideal for irregular or larger defect sites Absorbs blood and supports clot stabilization and tissue regeneration Easily cut and shaped to conform to defect contours Provides hemostatic protection and promotes predictable healing Biodegradable and completely resorbed during the natural healing process. Resorption time: within 30 days Manufacturer: Osteogenics, USA 10 Units/box 	10 X 20	 <p>RTMPLUG10</p>	
Cytoplast® RTM Foam			
	mm	Thickness: 3 mm	
<ul style="list-style-type: none"> Resorbable Collagen Scaffold Soft, sponge-like matrix ideal for irregular or larger defect sites Absorbs blood and supports clot stabilization and tissue regeneration Easily cut and shaped to conform to defect contours Provides hemostatic protection and promotes predictable healing Biodegradable and completely resorbed during the natural healing process. Resorption time: within 30 days Manufacturer: Osteogenics, USA 10 Units/box 	20 X 40	 <p>RTMFOAM10</p>	
Cytoplast® RTM Tape			
	mm	Thickness: 1 mm	
<ul style="list-style-type: none"> Resorbable Collagen Sheet Thin, flexible collagen layer for covering grafts or superficial wounds Excellent adaptability for flat or shallow surgical sites Serves as a resorbable barrier to protect and stabilize the wound area Can be layered or folded for added thickness when needed Simple handling, fast hydration, and natural tissue integration Resorption time: within 30 days Manufacturer: Osteogenics, USA 10 Units/box 	25 X 75	 <p>RTMTAPE10</p>	

Absorbable Xenograft Collagen

Zcore™ Expand				
Description	Type	Qty	Item code	Image
<ul style="list-style-type: none"> Composed of 65% porcine xenograft particulate and 35% porcine collagen by volume (80% xenograft and 20% collagen by weight) Hydrates and expands almost immediately when in contact with blood or saline Expands to fill voids in sockets or sinus defects Interconnected porous structure supports new bone formation and ingrowth High porosity (88% void space) reduces bulk density, leaving more room for new bone growth 	Socket	1	ZXSOCKET-1	
	Socket	5	ZXSOCKET-5	
	Sinus	1	ZXSINUSS	
	Sinus	1	ZXSINUSL	



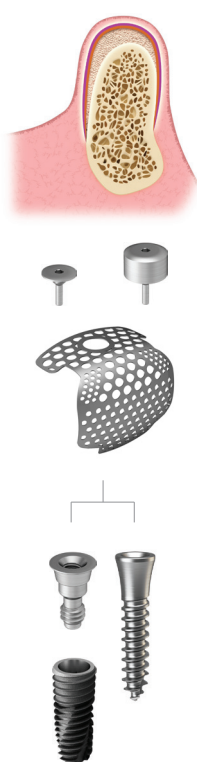
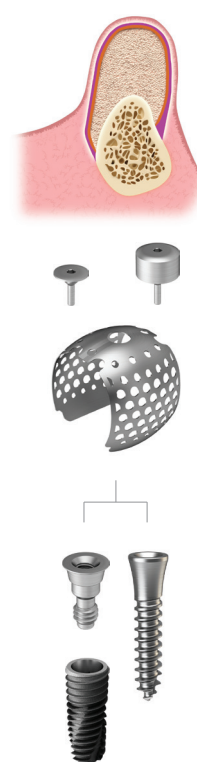

Zcore™ Form			
Description	CC	Item code	Image
<ul style="list-style-type: none"> Composed of 80% porcine xenograft particulate and 20% porcine collagen by volume (90% xenograft and 10% collagen by weight) Hydrates instantly when in contact with blood or saline Becomes moldable to fit defects of various shapes and sizes Interconnected porous structure supports new bone formation and ingrowth High porosity (88% void space) reduces bulk density, leaving more room for new bone growth 	0.5	ZF050	
	1.0	ZF100	
	2.0	ZF200	

OssBuilder Type

OssBuilder	
Description	
<ul style="list-style-type: none"> • 3D Pre-Formed Titanium Mesh • Pre-shaped 3D design—no trimming or bending needed • Fits various bone defects; stable, wrinkle-free placement • Wide range of sizes available • Mesh minimizes soft tissue exposure • Screw fixation prevents graft and mesh movement • Optimized pore structure for enhanced osteogenesis • Compatible with submerged and non-submerged techniques <ul style="list-style-type: none"> - Non-submerged surgery: Use with Healing Cap - Submerged surgery: Use with Cover Cap • Surgical Guidelines: <ul style="list-style-type: none"> - Simultaneous GBR with implant placement: Healing/ Cover Cap + OssBuilder + OB Anchor + Fixture - Narrow or insufficient bone: Healing/ Cover Cap + OssBuilder + Tenting Screw <p>※ Disposable, single use only</p>	
OB2	OB3
<p>Titanium Barrier Membrane for Alveolar Bone Regeneration</p> <ul style="list-style-type: none"> • Ideal for reconstructing minor vertical or horizontal bone defects in socket extractions, fenestrations, and dehiscence cases • Restores the alveolar ridge to its natural shape 	<p>Titanium Barrier Membrane for Ridge Augmentation</p> <ul style="list-style-type: none"> • Designed for cases with severe alveolar bone resorption • Enables vertical and horizontal ridge reconstruction of 5–10 mm in cases of severe alveolar bone resorption • Restores ridge volume for optimal implant placement 

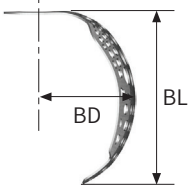
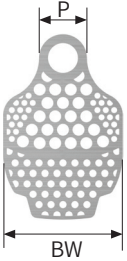
OssBuilder Type

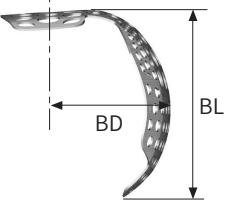
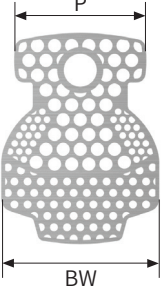
P = Proximal BW = Buccal Width BL = Buccal Length BD = Buccal Distance

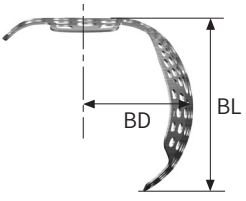
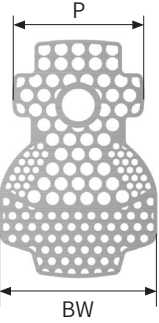
Lateral Builder						
Augmentation		P	BW	BL	BD	Item code
1 Wall   		4	8	7	5.5	SM1W487SB
		4	10	7	5.5	SM1W4107SB
		4	10	9	5.5	SM1W4109SB
2 Wall Buccal-Proximal   		7	9	7	5.5	SM2W797SB
		7	9	9	5.5	SM2W799SB
		10	12	7	5.5	SM2W10127SB
		10	12	9	5.5	SM2W10129SB
		12	12	7	5.5	SM2W12127SB
		12	12	9	5.5	SM2W12129SB
3 Wall   		7	9	7	5.5	SM3W797SB
		7	9	9	5.5	SM3W799SB
		10	12	7	5.5	SM3W10127SB
		10	12	9	5.5	SM3W10129SB
		12	12	7	5.5	SM3W12127SB
		12	12	9	5.5	SM3W12129SB

OssBuilder Type

BW = Buccal Width **BL** = Buccal Length **LL** = Ligual Length **BD** = Buccal Distance **LD** = Lingual Distance

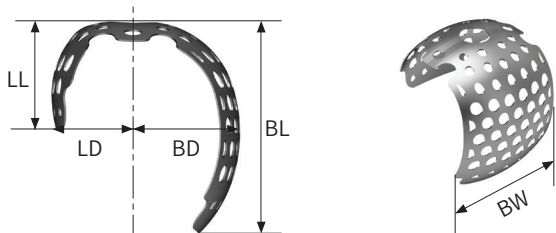
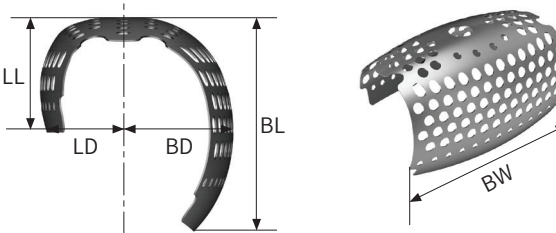
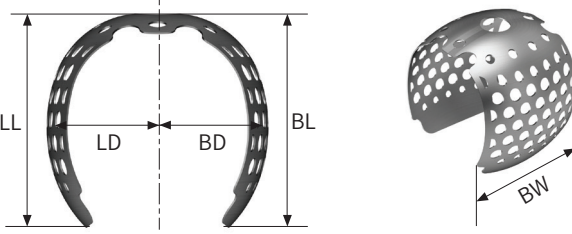
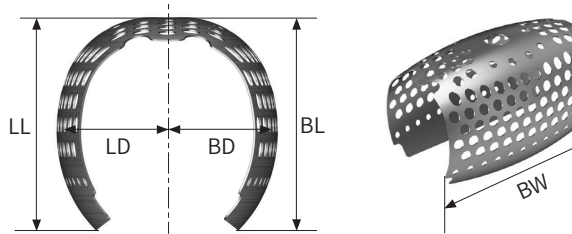
Jaw Builder						
Augmentation	BW	BL	LL	BD	LD	Item code
Horizontal 	10	7	3.5	3.7	3.7	SB3H107F
	10	9	4.5	3.7	3.7	SB3H109F
	10	11	6	3.7	3.7	SB3H1011F
Horizontal 	20	7	3.5	3.7	3.7	SB3H207F
	20	9	4.5	3.7	3.7	SB3H209F
	20	11	6	3.7	3.7	SB3H2011F
Vertical 	10	7	7	5.5	5.5	SB3V107F
	10	9	9	5.5	5.5	SB3V109F
	10	11	11	5.5	5.5	SB3V1011F
Vertical 	20	7	7	5.5	5.5	SB3V207F
	20	9	9	5.5	5.5	SB3V209F
	20	11	11	5.5	5.5	SB3V2011F

OssBuilder Type Components

Healing Cap (ET)					
Description	D	H	3.0	4.0	Image
<ul style="list-style-type: none"> For Non-submerged Procedure Compatible with OB2 and OB3 Use 0.9 Hex Hand Driver for tightening Recommended tightening torque: 5-8 Ncm ※ Disposable. Single use only	Ø4.0		SBHC4030	SBHC4040	
	Ø5.0		SBHC5030	SBHC5040	

Cover Cap (ET)					
Description	D	H	0.3		Image
<ul style="list-style-type: none"> For Submerged Procedure Compatible with OB2 and OB3 Use 0.9 Hex Hand Driver for tightening Recommended tightening torque: 5-8 Ncm ※ Disposable. Single use only	Ø4.0		SBCC4000		

OB Anchor (ET)							
Description						Image	
<ul style="list-style-type: none"> For ET implants Compatible with OB2 and OB3 Use 0.9 Hex Hand Driver for tightening Recommended tightening torque: 12-15 Ncm ※ Disposable. Single use only							
G/H	0	0.5	1.0	1.5	2.0	2.5	3.0
Mini	SBAC3500TSM	SBAC3505TSM	SBAC3510TSM	SBAC3515TSM	SBAC3520TSM	SBAC3525TSM	SBAC3530TSM
Regular	SBAC4000TSR	SBAC4005TSR	SBAC4010TSR	SBAC4015TSR	SBAC4020TSR	SBAC4025TSR	SBAC4030TSR

OssBuilder Type Components

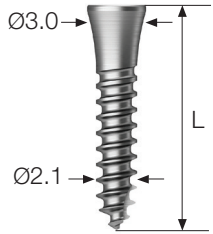
Tenting Screw (Internal Type)					
Description				Image	
<ul style="list-style-type: none"> • Can be used as an alternative to an implant in cases of insufficient bone volume or narrow ridge width • Compatible with OB2 and OB3 • Recommended placement depth: <ul style="list-style-type: none"> - Hard/normal bone: 3–5 mm - Soft bone: ≥ 5 mm • For slow placement, use a 0.9 hex torque driver • Compatible with ET cover caps and healing caps <p>※ Disposable. Single use only</p>					
L	8.5	10	11.5		13
	SBS2008I	SBS2010I	SBS2011I		SBS2013I

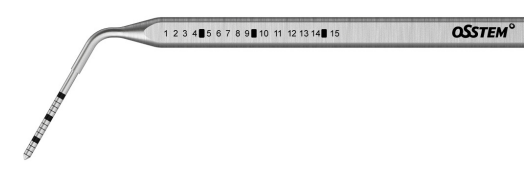
Defect Gauge	
Description	Image/Item code
<ul style="list-style-type: none"> • Measures vertical and horizontal bone defects • Features 1 mm markings with bold lines at 4–5, 9–10, and 14–15 mm • Enables accurate selection of OssBuilder 	
	HSM DG

HIOSSEN
IMPLANT

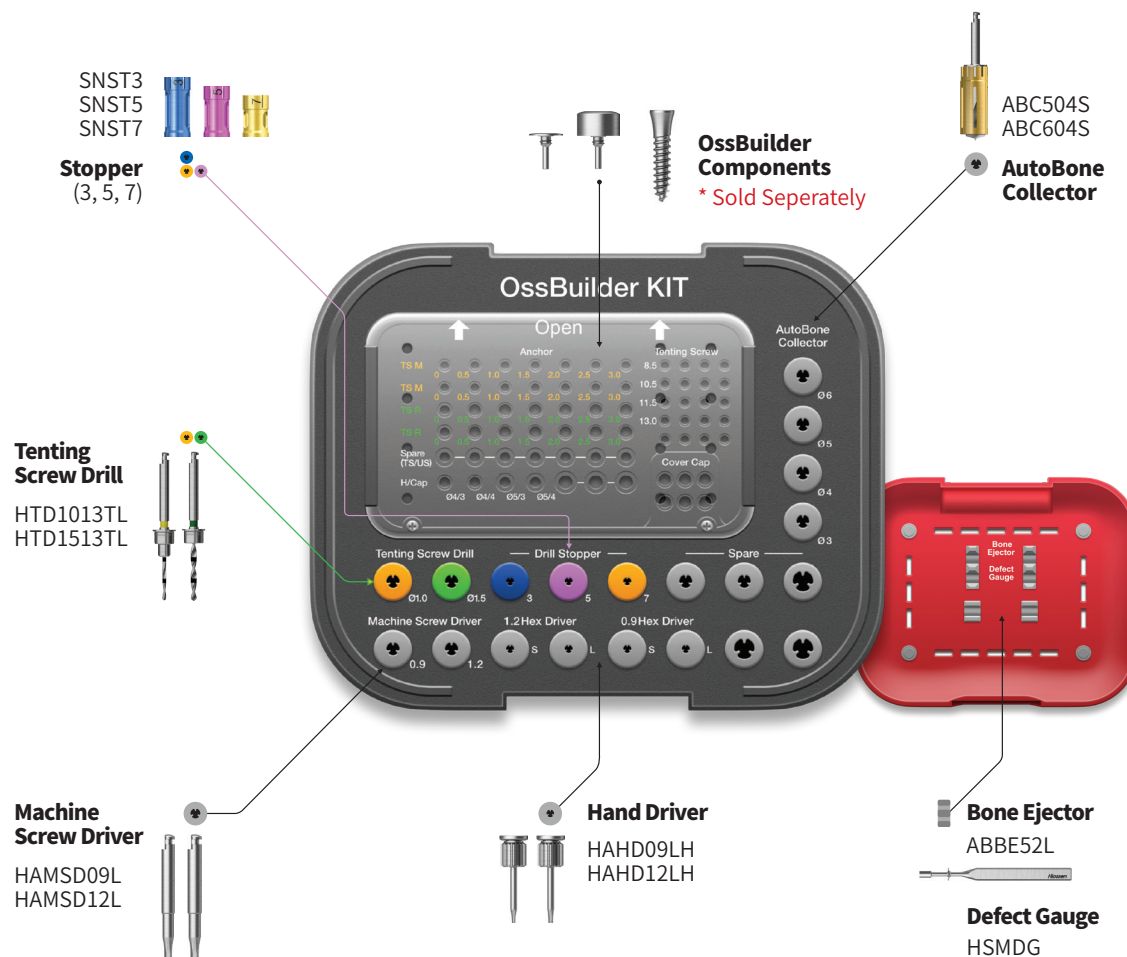

OssBuilder KIT (HGBRK)

- Complete kit containing all instruments required for efficient GBR procedures, designed for use with OssBuilder OB2/OB3, OB Anchor, Cover Cap, and Healing Cap
- Tenting screws support the management of extensive vertical and horizontal bone defects, including narrow ridge widths
- Allows immediate autogenous bone collection with the AutoBone Collector

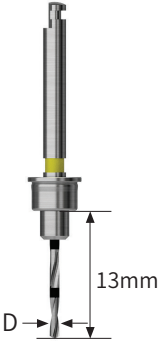

	Item	Specification	Default/Option
Middle plate	Tenting Screw Drill	Ø1.0, Ø1.5	Included
	Stopper	3, 5, 7mm	Included
	Machine Screw Driver	0.9 hex long, 1.2 hex long	Included
	Hex Hand Driver	0.9 hex long, 1.2 hex long	Included
	AutoBone Collector	Ø3.0, Ø4.0	Sold separately
		Ø5.0, Ø6.0	Included
	OB Anchor	ET mini, regular(0~1.5mm)	Sold separately
		ET mini, regular(2.0~3.0mm)	Sold separately
	Healing Cap	Ø4.0, Ø5.0(3, 4mm)	Sold separately
Tenting Screw	8.5, 10, 11.5, 13mm	Sold separately	
Cover Cap	-	Sold separately	
Bottom plate	Bone Ejector	-	Included
	Defect Gauge	-	Included

OssBuilder KIT Surgical Instruments

Tenting Screw Drill			
Description	Length	Ø1.0	Ø1.5
<ul style="list-style-type: none"> Used for drilling prior to tenting screw placement Drill selection: <ul style="list-style-type: none"> - Ø1.5 mm for hard bone - Ø1.0 mm for normal or soft bone Laser-marked depth indicators: 1–8 mm Recommended drilling speed: 1,200–1,500 rpm Stopper adjustment: 3–7 mm 	13mm		
		HTD1013TL	HTD1513TL

Stopper			
Description	L: 3mm	L: 5mm	L: 7mm
<ul style="list-style-type: none"> Used to connect to the tenting screw drill L = Length 			
	SNST3	SNST5	SNST7

AutoBone Collector

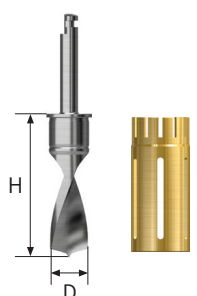
AutoBone Collector				
Description	D	Short	Long	Image
<ul style="list-style-type: none"> Attach the stopper to the drill at the first locking position before initial drilling Advance the drill to 4 mm (second locking position) while harvesting autogenous bone Stop the drill before removal once bone collection is complete Available sizes: D3.0 – D6.0 (Drill + Stopper) Recommended speed: 300–600 rpm Maximum usage: Up to 50 uses per drill and stopper <p>※ Refer to the Two-Stage Locking Stopper Guide</p>	Ø3.0	ABC304S	ABC304L	
	Ø4.0	ABC404S	ABC404L	
	Ø5.0	ABC504S	ABC504L	
	Ø6.0	ABC604S	ABC604L	

AutoBone Stopper				
Description	D	Short	Long	Image
<ul style="list-style-type: none"> Stops at a maximum depth of 4 mm for bone harvesting Collects and stores autogenous bone during drilling 	Ø3.0	ABC2ST304S	ABC2ST304L	
	Ø4.0	ABC2ST404S	ABC2ST404L	
	Ø5.0	ABC2ST504S	ABC2ST504L	
	Ø6.0	ABC2ST604S	ABC2ST604L	

Two-Stage Locking Stopper Guide

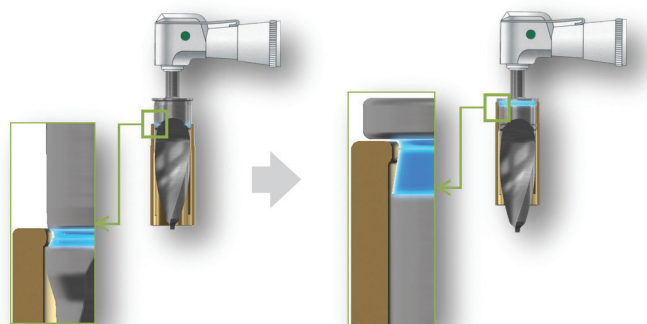

Engage the stopper at the first-stage locking position prior to drilling

Move and secure the stopper to the second-stage lock once the drilling depth is reached

AutoBone Collector

Bone Ejector		
Description	Dimension	Image
<ul style="list-style-type: none">Instrument for ejecting harvested autogenous bone from the stopper.	Ø3.0/Ø4.0/Ø5.0/Ø6.0	
	ABBE52L	

GBR KIT (HNGBRK)

- Comprehensive kit containing all essential instruments for GBR procedures using bone screws and bone tacks

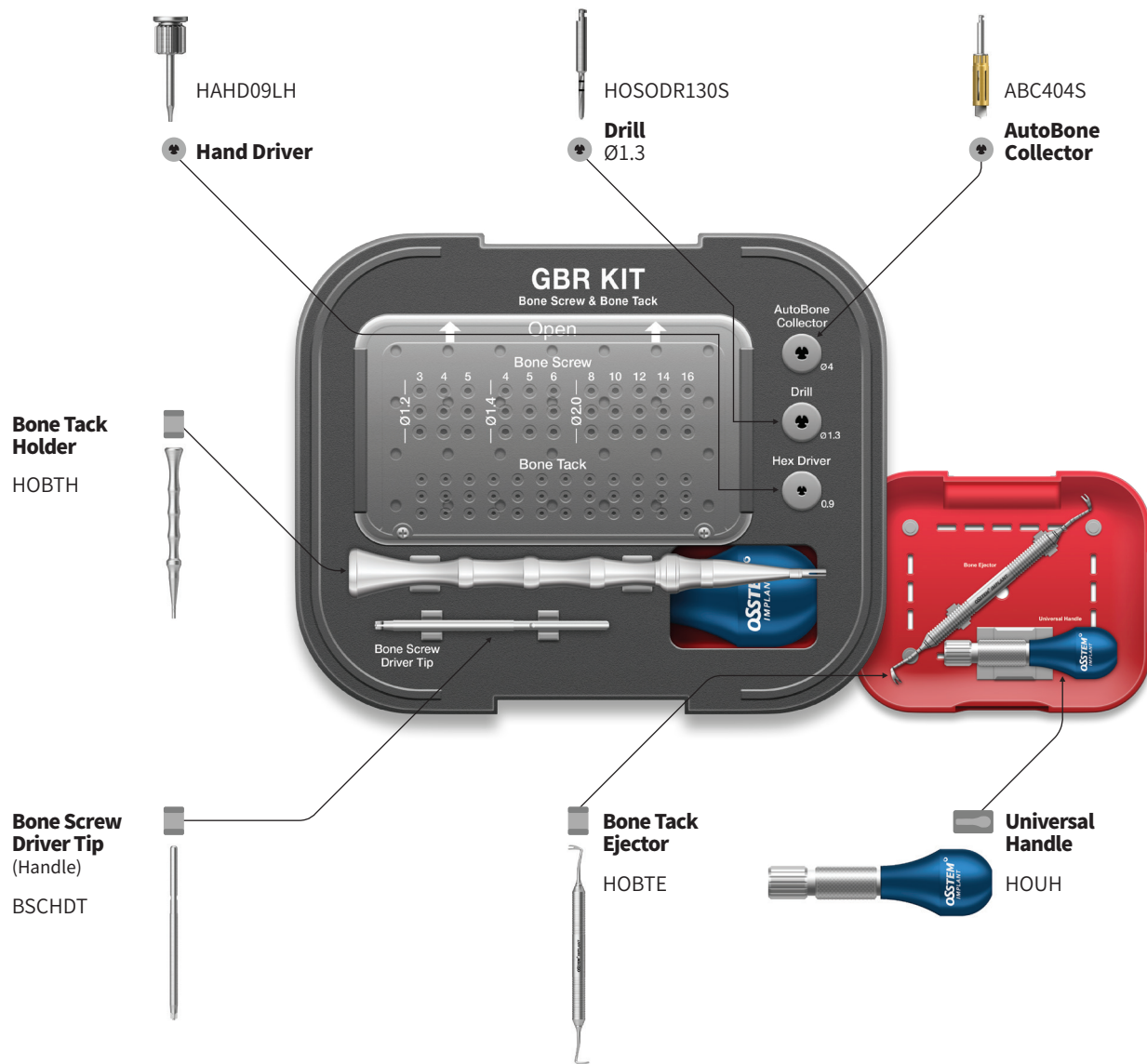

GBR KIT Surgical Instruments

Bone Screw

Bone Screw Driver Tip (Handle)	
Description/Item code	Image
<ul style="list-style-type: none"> Used by connecting to a universal handle Applied after the bone screw is fully seated vertically 	
Cross	
BSCHDT	

Universal Handle	
Description/Item code	Image
<ul style="list-style-type: none"> Used to connect the Bone Screw Driver Tip 	
Cross	
HOUH	

Bone Screw Driver (Engine)	
Description/Item code	Image
<ul style="list-style-type: none"> Used by connecting to a surgical engine Fully seat the bone screw vertically Recommended Speed: 20rpm 	
Cross	
HBSCMD	

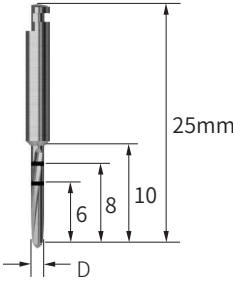



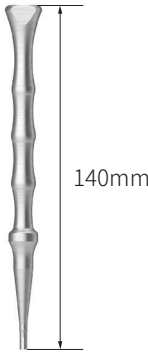



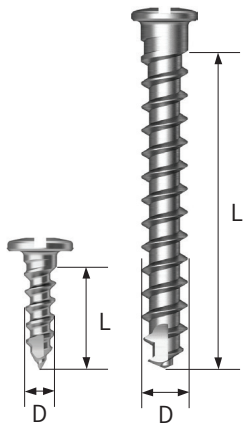

Ø1.3 Drill	
Description/Item code	Image
<ul style="list-style-type: none"> Used for Pre-drilling before D2.0 bone screw placement Recommended Speed: 800rpm 	
D	
Ø1.3 HOSODR130S	

Bone Tack

Bone Tack Holder	
Description/Item code	Image
<ul style="list-style-type: none"> Used to hold the Bone Tack Ergonomic design for easy handling Anti-rotation handle for a secure grip 	
Cross	
HOBTH	

Bone Tack Ejector	
Description/Item code	Image
<ul style="list-style-type: none"> Lever design for easy removal ※ If the bone tack is obstructed by bone, reverse and elevate it with a 0.9 mm hex driver before using the ejector 	
Cross	
HOBTE	





Membrane Fixation Screws

Bone Screw				
Description	L	Item code	Image	Guide
<p>Ø1.2</p> <ul style="list-style-type: none"> • Machine surfaced • Material Ti-6Al-4V • For fixation of non-resorbable membranes and OssBuilder • Sharp, self-drilling tip for easy placement • Improved resistance to fracture and bending <p>※ Disposable. Single Use Only</p>	3	BSCH1203		
	4	BSCH1204		
	5	BSCH1205		
<p>Ø1.4</p> <ul style="list-style-type: none"> • Machine surfaced • Material Ti-6Al-4V • For fixation of non-resorbable membranes and bone plates • Sharp, self-drilling tip for easy placement • Improved resistance to fracture and bending <p>※ Disposable. Single Use Only</p>	4	BSCH1404		
	6	BSCH1406		
	8	BSCH1408		
<p>Ø2.0</p> <ul style="list-style-type: none"> • Machine surfaced • Material Ti-6Al-4V • For block bone fixation • Requires pre-drilling (not self-drilling) <p>※ Disposable. Single Use Only</p>	8	BSCH2008		
	10	BSCH2010		
	12	BSCH2012		
	14	BSCH2014		
	16	BSCH2016		

Membrane Fixation Screws

Bone Tack			
Description	D	L: 3.0	Image
<ul style="list-style-type: none"> Used for Membrane Fixation (Resorbable or Non-resorbable) Easily attaches with a mallet without drilling Machined surface Material: Ti-6Al-4V <p>※ Disposable. Single Use Only</p>	Ø2.5	OBT3	<p>The image shows a technical drawing of a Bone Tack screw. It features a hexagonal head with a diameter of 2.5 mm and a height of 0.85 mm. The threaded portion has a length of 7.0 mm. The total length of the screw, including the head, is 3.0 mm.</p>

Impression Materials HySil Plus

Hysil Plus			
Description	Light Body - 50 ml	Item code	Image
<ul style="list-style-type: none"> • Super-hydrophilic VPS impression material for accurate impression-taking • Sufficient working time, fast intraoral setting time <ul style="list-style-type: none"> - Working time : 2min - Setting time : 2 min 30 sec • High-quality raw material from Germany 	<p>4 cartridges 15 cartridges</p>	<p>ESS50LS ESS50LSB</p>	
	<p>Mono Body - 50 ml</p>		
	<p>4 cartridges 15 cartridges</p>	<p>ESS50MS ESS50MSB</p>	
	<p>Heavy Body - 50 ml</p>		
	<p>4 cartridges 15 cartridges</p>	<p>ESS50HS ESS50HSB</p>	
	<p>Bite - 50 ml</p>		
	<p>4 cartridges</p>	<p>ESS50B</p>	
<p>Putty - 400 ml</p>			
<p>Base 400 ml Catalyst 400 ml</p>	<p>ESS400P</p>		

Impression Materials Accessory

Dispenser Gun		
Description	Item code	Image
50ml Dispenser Gun	JFS50DA	

Mixing Tips		
Description	Item code	Image
50ml Heavy/Mono Body Mixing tips, 300 EA 50ml Heavy/Mono Body Mixing tips, 100 EA	OMTH300 OMTH100	
50ml Light Body Mixing Tips, 300 EA 50ml Light Body Mixing Tips, 100 EA	OMTL300 OMTL100	

Suture Non-Absorbable

UNIFY® Nylon Surgical Sutures				
Description	Thread Size: 3/0	Item code	Image	
<ul style="list-style-type: none"> Minimal tissue reaction Smooth flow through tissue while maintaining optimal knot security Ultra sharp needle point for atraumatic tissue penetration Needle coated with silicone for smooth tissue passage Thread type: Monofilament Color: Black Strength duration: 2 years 	<ul style="list-style-type: none"> Needle Spec: <ul style="list-style-type: none"> - 19 mm, 3/8 Circle Reverse Cutting Comparable Needles: FS-2/C-13/C6 Thread Length: 18 in (45 cm) Color: Black Packing: 12 EA/Box 	M-N318R19	 <p>The image shows a box of UNIFY Nylon Surgical Sutures. The box is white with green and black accents. It features the UNIFY logo and the text 'Nylon Surgical Sutures'. Below the logo, there are instructions: 'Sterile. Do not resterilize. STERILE (ES)'. It also includes a warning: 'Content and Size Per Label. Single use only. Do not use if package is damaged. For use by medical professionals only. UNIFY® Surgical Sutures meet all U.S.P. requirements.' At the bottom, it says 'Contains: 12 individual sterile packs per box' and 'AD Surgical'.</p>	
	Thread Size: 4/0	<ul style="list-style-type: none"> Needle Spec: <ul style="list-style-type: none"> - 19 mm, 3/8 Circle Reverse Cutting Comparable Needles: FS-2/C-13/C6 Thread Length: 18 in (45 cm) Color: Black Packing: 12 EA/Box 		M-N418R19
	Thread Size: 5/0	<ul style="list-style-type: none"> Needle Spec: <ul style="list-style-type: none"> - 19 mm, 3/8 Circle Reverse Cutting Comparable Needles: FS-2/C-13/C6 Thread Length: 18 in (45 cm) Color: Black Packing: 12 EA/Box 		M-N518R19

UNIFY® - PTFE Surgical Sutures			
Description	Thread Size: 3/0	Item code	Image
<ul style="list-style-type: none"> Very smooth surface, resulting in minimal tissue trauma Maintains tensile strength Biologically inert and chemically non-reactive Ultra sharp needle point for atraumatic tissue penetration Needle coated with silicone for smooth tissue passage Thread type: Monofilament White, Uncoated Strength duration: Life time 	<ul style="list-style-type: none"> Needle Spec: <ul style="list-style-type: none"> - 16mm, 3/8 Circle Reverse Cutting Comparable Needles: FS-3/C-12/C22 Thread Length: 18 in (45 cm) Color: White Packing: 12 EA/Box 	M-F318R16	 <p>The image shows a box of UNIFY PTFE Surgical Sutures. The box is white with black and green accents. It features the UNIFY logo and the text 'PTFE Surgical Sutures'. Below the logo, there are instructions: 'Sterile. No volver a esterilizar. STERILE (ES)'. It also includes a warning: 'Contento y tamaño por etiqueta. No utilizar si el paquete exterior está dañado. Solo para uso profesional médico. UNIFY® Sutures quirúrgicas cumplen todos los U.S.P. requisitos.' At the bottom, it says 'Contains: 12 packages sterile individual per box' and 'AD Surgical'.</p>

Suture Non-Absorbable

Cytoplast - PTFE Sutures				
Description	CS-04 PTFE Suture (USP 2-0)	Item code	Image	
<ul style="list-style-type: none"> The ideal soft monofilament suture for dental bone grafting and implant cases Monofilament construction prevents bacterial wicking into surgical sites Biologically inert PTFE is non-cytotoxic Soft and comfortable for patients Excellent handling and knot security Little or no package memory 300 series stainless steel needles Suture Length: 45 cm Packing: 12 EA/Box 	<ul style="list-style-type: none"> Thread Size: 2/0 Needle Spec: 19 mm, 3/8 Circle precision reverse cutting Thread Length: 18 in (45 cm) Color: White Packing: 12 EA/Box 	CS0418		
	CS-05 PTFE Suture (USP 3-0)			
	<ul style="list-style-type: none"> Thread Size: 3/0 Needle Spec: 16mm, 3/8 Circle precision reverse cutting Thread Length: 18 in (45 cm) Color: White Packing: 12 EA/Box 	CS0518		
	CS-06 Perio PTFE Suture (USP 4-0)			
	<ul style="list-style-type: none"> Thread Size: 4/0 Needle Spec: 13mm, 3/8 Circle taper point (non-cutting) Thread Length: 18 in (45 cm) Color: White Packing: 12 EA/Box 	CS0618PERIO		
	CS-06 Premium PTFE Suture (USP 4-0)			
<ul style="list-style-type: none"> Thread Size: 4/0 Needle Spec: 13mm, 3/8 Circle precision reverse cutting Thread Length: 18 in (45 cm) Color: White Packing: 12 EA/Box 	CS0618PREM			
CS-06 RC PTFE Suture (USP 4-0)				
<ul style="list-style-type: none"> Thread Size: 4/0 Needle Spec: 16mm, 3/8 Circle precision reverse cutting Thread Length: 18 in (45 cm) Color: White Packing: 12 EA/Box 	CS0618RC			

Suture Absorbable

UNIFY®- PDO Surgical Sutures			
Description	Thread Size: 2/0	Item code	Image
<ul style="list-style-type: none"> High tensile strength Extended holding strength, maintains tensile strength for up to six weeks Lower tissue reaction than chromic gut sutures with no risk of toxicity Eliminates bacterial migration along suture line Ultra sharp needle point for atraumatic tissue penetration Needle coated with silicone for smooth tissue passage Predictable absorption profile Thread type: Monofilament Color: Violet Strength duration: 55-65 days Absorb duration: 180-200 days 	<ul style="list-style-type: none"> Needle Spec: - 24mm, Circle Reverse Cutting Comparable Needles: FS-1/C-14/C7 Thread Length: 30 in (75cm) Packing: 12 EA/Box 	L-D230R24	
	Thread Size: 3/0		
	<ul style="list-style-type: none"> Needle Spec: - 19 mm, Circle Reverse Cutting Comparable Needles: FS-2/C-13/C6 Thread Length: 18 in (45 cm) Packing: 12 EA/Box 	M-D318R19	
	Thread Size: 4/0		
	<ul style="list-style-type: none"> Needle Spec: - 19 mm, Circle Reverse Cutting Comparable Needles: FS-2/C-13/C6 Thread Length: 18 in (45 cm) Packing: 12 EA/Box 	M-D418R19	
	Thread Size: 5/0		
	<ul style="list-style-type: none"> Needle Spec: - 19 mm, Circle Reverse Cutting Comparable Needles: FS-2/C-13/C6 Thread Length: 18 in (45 cm) Packing: 12 EA/Box 	M-D518R19	

UNIFY®- PGCL Surgical Sutures			
Description	Thread Size: 2/0	Item code	Image
<ul style="list-style-type: none"> Very high tensile strength initially High in vivo strength retention Excellent handling properties and high pliability Very low incidence of infection and trauma Ultra-sharp needle point for atraumatic tissue penetration Needle coated with silicone for smooth tissue passage Predictable absorption profile Thread type: Monofilament Color: Undyed, Violet Strength duration: 14-21 days Absorb duration: 90-120 days 	<ul style="list-style-type: none"> Needle Spec: - 24mm, Circle Reverse Cutting Comparable Needles: FS-1/C-14/C7 Thread Length: 30 in (75cm) Color: Undyed Packing: 12 EA/Box 	L-Q230R24	
	Thread Size: 3/0		
	<ul style="list-style-type: none"> Needle Spec: - 19 mm, Circle Reverse Cutting Comparable Needles: FS-2/C-13/C6 Thread Length: 18 in (45 cm) Color: Undyed Packing: 12 EA/Box 	M-Q318R19	
	Thread Size: 4/0		
	<ul style="list-style-type: none"> Needle Spec: - 19 mm, Circle Reverse Cutting Comparable Needles: FS-2/C-13/C6 Thread Length: 18 in (45 cm) Color: Undyed Packing: 12 EA/Box 	M-Q418R19	
	Thread Size: 5/0		
	<ul style="list-style-type: none"> Needle Spec: - 19 mm, Circle Reverse Cutting Comparable Needles: FS-2/C-13/C6 Thread Length: 18 in (45 cm) Color: Violet Packing: 12 EA/Box 	M-Q518R19	

Suture Absorbable

UNIFY®- Nylon Surgical Sutures			
Description	Thread Size: 6/0	Item code	Image
<ul style="list-style-type: none"> • Our highest performing suture needles for the most demanding surgical procedures • Needle maintains shape and sharpness 3X longer than regular needles • Ultra sharp Precision Point needles provide clean penetration with minimal drag for delicate procedures • MULTICUT™ needle technology to ensure excellent tissue penetration and control, cut after cut • Needles crafted from UNIALLOY™ - a reinforced AISI 300 series stainless steel that provides the highest ductility and bending strength • Minimal tissue reaction • Smooth flow through tissue while maintaining optimal knot security • Thread type: Monofilament • Color: Black or Clear (undyed) • Strength duration: 2 Year • Absorb duration: N/A 	<ul style="list-style-type: none"> • Needle Spec: <ul style="list-style-type: none"> - 13mm, Circle Reverse Cutting • Comparable Needles: P-3/P-13/C3 • Thread Length: 18" (45 cm) • Color: Black • Packing: 12 EA/Box 	S-N618R13	
	<p style="text-align: center;">Thread Size: 4/0</p> <ul style="list-style-type: none"> • Needle Spec: <ul style="list-style-type: none"> - 19 mm, Reverse Cutting • Compatible Needles: PS-2/P-12/PC31 • Thread Length: 18" (45 cm) • Color: Brown • Packing: 12 EA/Box 	PMC-318R19	

UNIFY®- Premium Chromic Gut Sutures				
Description	Thread Size: 3/0	Item code	Image	
<ul style="list-style-type: none"> • Needle maintains shape and sharpness up to 3X longer • Ultra-sharp Precision Point design for clean penetration with minimal drag • MULTICUT™ technology for excellent tissue penetration and control • UNIALLOY™ stainless steel for superior ductility and bending strength • Chromic coating extends suture integrity and reduces tissue reactivity • High-quality collagen minimizes fraying • Retains tensile strength for 10–14 days • Easy, secure knot tying • Predictable absorption profile • Thread type: Monofilament • Strength duration: 10–14 days • Absorption: 56–72 days 	<ul style="list-style-type: none"> • Needle Spec: <ul style="list-style-type: none"> - 19 mm, Reverse Cutting • Compatible Needles: PS-2/P-12/PC31 • Thread Length: 18" (45 cm) • Color: Brown • Packing: 12 EA/Box 	PMC-318R19		
	<p style="text-align: center;">Thread Size: 4/0</p>			
	<ul style="list-style-type: none"> • Needle Spec: <ul style="list-style-type: none"> - 19 mm, Reverse Cutting • Compatible Needles: PS-2/P-12/PC31 • Thread Length: 18" (45 cm) • Color: Brown • Packing: 12 EA/Box 	PMC-418R19		

Suture Absorbable

PGA Resorba				
Description	DSM18 Thread Size: 4/0	Item code	Image	
<ul style="list-style-type: none"> • PGA (polyglycolic acid) • Special resorbable coating reduces soft tissue drag • Maintains 50% tensile strength for up to 21 days • 300 series stainless steel needles • Suture Length: 45 cm • Packing: 12 EA/Box 	<ul style="list-style-type: none"> • Needle Spec: <ul style="list-style-type: none"> - 18mm, 3/8 Circle Reverse Cutting • Thread Length: 18 in (45 cm) • Color: Violet • Packing: 12 EA/Box 	OD03202		
	HRT18 Thread Size: 4/0			
	<ul style="list-style-type: none"> • Needle Spec: <ul style="list-style-type: none"> - 18mm, 1/2 Circle Round-Bodied Cutting • Thread Length: 18 in (45 cm) • Color: Violet • Packing: 12 EA/Box 	OD03100		
	DS18 Thread Size: 5/0			
	<ul style="list-style-type: none"> • Needle Spec: <ul style="list-style-type: none"> - 18mm, 3/8 Circle Reverse Cutting • Thread Length: 18 in (45 cm) • Color: Violet • Packing: 12 EA/Box 	OD03400		
HRT17 Thread Size: 5/0				
<ul style="list-style-type: none"> • Needle Spec: <ul style="list-style-type: none"> - 17mm, 1/2 Circle Round-Bodied Cutting • Thread Length: 18 in (45 cm) • Color: Violet • Packing: 12 EA/Box 	OD03500			



NEEDLE CODE DETAIL

DSM	3/8 CIRCLE PREMIUM REVERSE CUTTING		
DS	3/8 CIRCLE STANDARD REVERSE CUTTING		
HRT	1/2 CIRCLE ROUND-BODIED CUTTING		
HR	1/2 CIRCLE ROUND-BODIED		
HSM	1/2 CIRCLE PREMIUM REVERSE CUTTING		

Suture Absorbable

Glycolon Resorba				
Description	DSM18 Thread Size: 4/0	Item code	Image	
<ul style="list-style-type: none"> • PGA - PCL copolymer (polyglycolic acid and polycaprolactone) • Monofilament construction prevents bacterial wicking into surgical sites • Maintains 50% tensile strength for 11 - 13 days • 300 series stainless steel needles • Suture Length: 45 cm • Packing: 12 EA/Box 	<ul style="list-style-type: none"> • Needle Spec: <ul style="list-style-type: none"> - 18mm, 3/8 Circle Reverse Cutting • Thread Length: 18 in (45 cm) • Color: Violet • Packing: 12 EA/Box 	OD01203		
	DSM13 Thread Size: 5/0			
	<ul style="list-style-type: none"> • Needle Spec: <ul style="list-style-type: none"> - 18mm, 3/8 Circle Reverse Cutting • Thread Length: 18 in (45 cm) • Color: Violet • Packing: 12 EA/Box 	OD01210		
	DSM16 Thread Size: 5/0			
	<ul style="list-style-type: none"> • Needle Spec: <ul style="list-style-type: none"> - 16mm, 3/8 Circle Reverse Cutting • Thread Length: 18 in (45 cm) • Color: Violet • Packing: 12 EA/Box 	OD01214		
	DSM18 Thread Size: 5/0			
	<ul style="list-style-type: none"> • Needle Spec: <ul style="list-style-type: none"> - 18mm, 3/8 Circle Reverse Cutting • Thread Length: 18 in (45 cm) • Color: Violet • Packing: 12 EA/Box 	OD01212		
DSM13 Thread Size: 6/0				
<ul style="list-style-type: none"> • Needle Spec: <ul style="list-style-type: none"> - 13mm, 3/8 Circle Reverse Cutting • Thread Length: 18 in (45 cm) • Color: Violet • Packing: 12 EA/Box 	OD01213			

NEEDLE CODE DETAIL

DSM	3/8 CIRCLE PREMIUM REVERSE CUTTING		
DS	3/8 CIRCLE STANDARD REVERSE CUTTING		
HRT	1/2 CIRCLE ROUND-BODIED CUTTING		
HR	1/2 CIRCLE ROUND-BODIED		
HSM	1/2 CIRCLE PREMIUM REVERSE CUTTING		

HIOSSEN
IMPLANT

DENTAL EQUIPMENT

K5 Dental Unit Chair	282
K3 Dental Unit Chair	283
Dental Handpieces	284
T2 Plus CBCT	287
TRIOS® Intraoral Scanner	288
TRIOS® MOVE Pro & MOVE+	291
MEDIT Intraoral Scanner	292
SM7	294
SM5	295
Intraoral Sensor - S2	
Intraoral Camera - SNAP	296
Orthodontic/Prosthetic - E-Driver	
Endodontics - UC-Cutter	297
ISQ Stability Tester - IS4™	298
ISQ Stability Tester - IS3™	299
Multipeg™ Assortment	300

K5 Dental Unit Chair

K5 Dental Unit Chair

Description

- Patient Chair - High performance electric motor with noise filter
- Cuspidor Unit - Water and air delivery and intake & outtake unit connection to junction box with 90° rotatable spittoon
- Doctor Table/Delivery System
 - Holds various handpieces and master control unit with LCD display
- Assistant Delivery System - Controls the chair's movement/Holds instruments
- LED Dental Light - Touchless on/off sensor
- Improved Dr. Stool design - Allows for better customization of lumbar support
- Wireless Foot Control - Controls chair positioning and handpieces
- Warm water supply
- Wide range of color options to match any clinic's interior settings

※ 7 Year Limited Warranty, please refer to the full warranty statement



Brown

Dark Blue

Dark Violet

Classic Blue

Gold

Orange

Royal Red

Light Green

Ivory

K3™ Dental Unit Chair

K3™ Dental Unit Chair

Description

- Patient Chair - High performance hydraulic motor with noise filter
- Cuspidor Unit - Water and air delivery and intake & outtake unit connection to junction box
(Available without the cuspidor unit)
- Doctor Table/Delivery System - Holds various handpieces and master control unit with LCD display
- Assistant Delivery System - Controls the chair's movement/Holds instruments
- LED Dental Light - Touchless on/off sensor
- Foot Control - Controls chair positioning and handpieces
- Wide range of color options to match any clinic's interior settings

※ 7 Year Limited Warranty, please refer to the full warranty statement

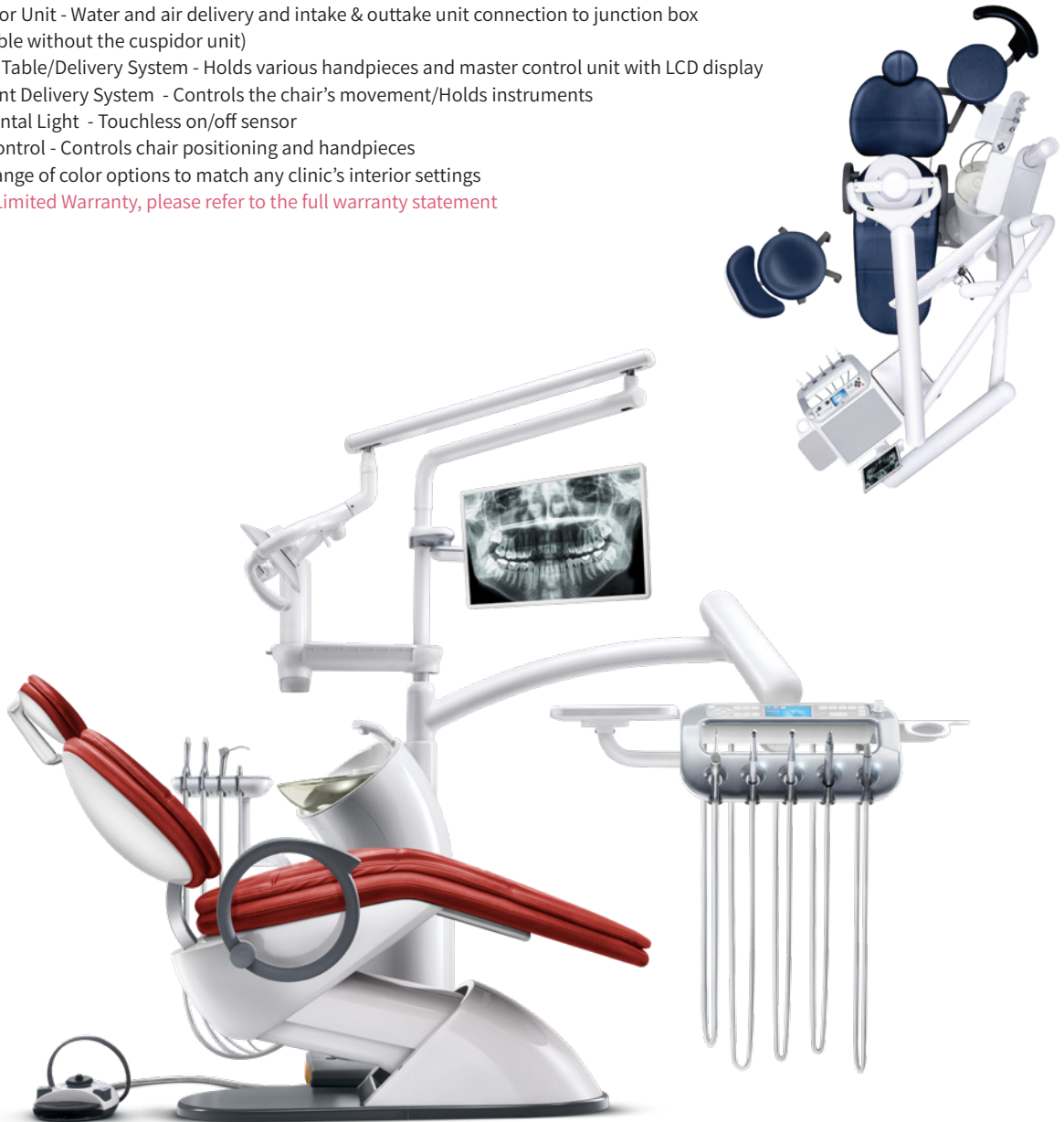

Brown



Dark Blue



Dark Violet



Blue



Gold









Red





Ivory



Dental Handpieces

NSK - Air Handpieces	
Description	Image / Item code
<p>Standard Head</p> <ul style="list-style-type: none"> Bur diameter: Ø 1.6 mm friction-grip (FG) burs Power: 26 W output Quattro Spray (4-port water spray) for effective bur cooling Cellular glass fiber-optic illumination Ceramic bearings and Clean Head anti-retraction system for durability and contamination control 	 <p>H311L</p>
<p>Mini Head</p> <ul style="list-style-type: none"> Bur diameter: Ø 1.6 mm friction-grip (FG) burs Power: 23 W output Head size: Ø10.6 × H12.4 mm Quattro Spray (4-port water spray) for efficient cooling Cellular glass fiber-optic illumination Ceramic bearings and Clean Head System for longer service life and reduced contamination risk 	 <p>H511L</p>
<p>Coupling</p>	 <p>CL</p>

NSK - Electric Handpieces	
Description	Image / Item code
<p>Electric Slow-Speed Contra-Angle</p> <ul style="list-style-type: none"> 1:1 direct drive transmission Bur diameter: Ø 2.35 mm latch-type (RA / CA burs) Single water spray cooling system Cellular glass fiber optics for illumination 	 <p>E200IL</p>
<p>Electric High-Speed Contra-Angle</p> <ul style="list-style-type: none"> 1:5 speed-increasing gear ratio Bur diameter: Ø 1.6 mm friction-grip (FG burs) Quattro spray cooling system for improved bur cooling Cellular glass fiber optics for illumination 	 <p>E205IL</p>
<p>Electric Slow-Speed Straight</p> <ul style="list-style-type: none"> 1:1 direct drive straight attachment Bur diameter: Ø 2.35 mm straight (HP burs) Single spray cooling system Stainless-steel body for durability 	 <p>E400I</p>

Dental Handpieces

Bien Air - Air Handpieces	
Description	Image / Item code
<p>Standard Head</p> <ul style="list-style-type: none"> Up to 380,000 RPM with 20 W power for efficient cutting performance Integrated LED illumination for improved visibility in the treatment area 4-port spray system provides optimal cooling and debris removal Push-button bur change system for quick and safe bur replacement Anti-retraction system helps reduce cross-contamination risk 	 <p>1601153BAA</p>
<p>Coupling</p>	 <p>1600902BAA</p>

Bien Air - Electric Handpieces	
Description	Image / Item code
<p>Electric Slow-Speed Contra-Angle</p> <ul style="list-style-type: none"> 1:1 transmission ratio Bur diameter: Ø 2.35 mm latch-type (RA) burs Maximum speed up to 40,000 RPM depending on motor Fiber-optic illumination 	 <p>1600384BAA</p>
<p>Electric High-Speed Contra-Angle</p> <ul style="list-style-type: none"> 1:5 speed-increasing gear ratio Up to ~200,000 RPM with a 40k electric motor Bur diameter: Ø 1.6 mm friction-grip (FG) burs Internal spray cooling Fiber-optic illumination 	 <p>1600386BAA</p>
<p>Electric Slow-Speed Straight</p> <ul style="list-style-type: none"> 1:1 transmission ratio for surgical, lab, and implant procedures Bur diameter: Ø 2.35 mm straight handpiece burs (HP) Locking ring bur retention system Internal irrigation 	 <p>1600383BAA</p>

Dental Handpieces

Dmetec Scaler	
Description	Image / Item code
<ul style="list-style-type: none">• Premium Quality - Made in South Korea.• Automatic feedback system for built-in circuit module keeps constant strong power• Regulator controls output power moderately in different quantity of tartar• Circuit module to enhance accuracy	 <p data-bbox="1118 653 1250 678">COMPACT-HP</p>

T2 Plus CBCT

T2 Plus Dental CBCT

Description

- Faster scan time, higher resolution and AI-powered 3D diagnostics
 - 2 in 1 system: CT + Pano / 3 in 1 system: CT + Pano + Cephalo
 - Multiple FOV for a Wide Range of Applications:
 - * 5x5, 8x9, 10x9, 12x9, 15x9 (Standard) & 15x15 (Stitching)
 - High Resolution Voxel Size to Provide Clear Images
 - Simplified TMJ Imaging
 - User-Friendly Operation
 - Automated voice guidance to reduce re-imaging
 - Improved radiolucent temple support for stable patient positioning
- ※ 5 Year Full Warranty, please refer to the full warranty statement
- ※ Up to 10 Year Extended Warranty is available for purchase



TRIOS® 6 Intraoral Scanner

TRIOS® 6 Wireless Pod	
Description	Image
<ul style="list-style-type: none"> • Up to 110% higher scan resolution • Wireless comfort • Improved battery life • Hyper-spectral imaging <p>※ Engagement apps included</p>	
22003200	

Accessories

TRIOS® 6 Protection Tip
Image

22002382

TRIOS® 6 Battery Charger
Image

22002384

TRIOS® 6 Battery (3)
Image

22002385

TRIOS® 6 Tip (3)
Image

22002381

TRIOS® 6 Ready Tips (25)
Image

10036057

TRIOS® 6 Sleeves (100)
Image

22002380

TRIOS® 5 Intraoral Scanner

TRIOS® 5	
Description	Image
<ul style="list-style-type: none"> • FDA Approved Caries Detection Aid • Next-level ergonomics • TriosShare • ScanAssist • Remote Control Mouse Mode • Improved battery life • LED and Haptic feedback ※ Engagement apps included 	
22004025	

Accessories

TRIOS® 5 Protection Tip
Image

22002382

TRIOS® 5 Battery Charger
Image

22002384

TRIOS® 5 Battery (3)
Image

22002385

TRIOS® 5 Tip (3)
Image

22002381

TRIOS® 5 Ready Tips (25)
Image

10036057

TRIOS® 5 Sleeves (100)
Image

22002380

TRIOS® 3 Intraoral Scanner

TRIOS® 3 (2024)	
Description	Image
<ul style="list-style-type: none"> Award-winning TRIOS 3 technology Wired Only Reversible tips ※ Engagement apps included 	
22004000	

Accessories

TRIOS® 3 Protection Tip
Image

82610032

TRIOS® 3 Calibration Tip
Image

82610052

TRIOS® 3 Calibration Kit
Image

22002384

TRIOS® Move+

TRIOS® MOVE PRO	
Description	Image
<ul style="list-style-type: none"> • 18.5" full HD touchscreen and upgraded PC specifications • Optimized for TRIOS 5 and TRIOS 6 • New detachable and height-adjustable storage tray for scanner accessories • Fully adjustable swivel arm • Cable hook for easier moveability, keeping cables neatly secured and tangle-free 	
22003210	

TRIOS® MOVE+ (Standalone Accessory)	
Description	Image
<ul style="list-style-type: none"> • Navigate directly on the LCD touch screen: 15.6" (MOVE+): USB 2.0 port for import and export of your scans • Maneuver the arm and swivel screen • Comes with a powerful PC • Designed for fast and smooth scanning with TRIOS • Unrivaled open system • Secure access to the most up-to-date technology, materials, partners and prices 	
22002375	

MEDIT Intraoral Scanner

MEDIT i900 Mobility	
Description	Image
<ul style="list-style-type: none"> • Light: 242g • 3rd-gen optical engine with 10-bit color depth and 3D-in-motion video technology • 1-hour continuous scanning • Field of View (FOV): 18X15mm • Two programmable buttons with touch-control functionality (pan, zoom, rotate) • Wi-Fi 6E (6GHz) direct connection to iPad or laptop 	
MO3-I900M(NA)	

MEDIT i900 Classic	
Description	Image
<ul style="list-style-type: none"> • Ultra light: 165g • Intuitive click-to-scan, button interface • AI-powered scanning • Free applications • No Subscriptions • 3 year warranty 	
MO4-I900C	

MEDIT i700 Wired	
Description	Image
<ul style="list-style-type: none"> • 180 Degree reversible tip • Free applications • No subscription • Remote Control Mode • UV-C Disinfection • Light scanner for comfort: 245g 	
MD-IS0200	

MEDIT Intraoral Scanner

MEDIT i600	
Description	Image
<ul style="list-style-type: none">• 180 Degree reversible tip• Free applications• No subscriptions• Light scanner for comfort: 245g	 A blue and white handheld intraoral scanner with a white tip and a white base. The device is shown from a side profile, resting on a white cylindrical stand. A white cable is attached to the back of the handle.
MD-IS0100	

SM7 Implant Engine

SM7 Unit	
Description	Image
<ul style="list-style-type: none"> • High Precision Calibration • Offers Advanced Technology • Compact Body and Large LCD Display • LED Optics for Safe, More Accurate Treatment • Well-Balanced, compact and light weight micro-motor 	
SM3US1	

SM7 Contra-Angle Hand Piece	
Description	Image
<ul style="list-style-type: none"> • Product Name: SM7 Contra-angle Hand Piece • Body Material: Titanium • Transmission: Gear Ratio 20:1 Reduction • Maximum Speed: 2,000 min-1 • Maximum Torque: 80 Ncm 	
S200EL	

Irrigation Tube	
Description	Image
<ul style="list-style-type: none"> • SM7 Irrigation Tube (10 packs) - Disposable 	
Y900114	

SM5 Implant Engine

SM5 Unit	
Description	Image
<ul style="list-style-type: none"> • Intelligent Power and Precise Torque • One Touch Auto-Calibration • Simple User Friendly Operation • Enhanced workflow through easy programming 	
SM5US1	

Hand Piece SURGmatic S201L (Optic)	
Description	Image
<ul style="list-style-type: none"> • Product Name : S201L • Reduction ratio 20:1 • Removable head, easy to clean • Small head with internal cooling system • Speed: 15 – 2,000 rpm • Maximum torque: 55 Ncm 	
1.012.1870	

Irrigation Tube	
Description	Image
<ul style="list-style-type: none"> • Tube Set Sterile S600 (10EA) - Disposable 	
1.009.8757	

Intraoral Sensor

S2	
Description	Image
<ul style="list-style-type: none"> • Premium Intraoral Sensor • Clear images with 25lp/mm resolution • Durable for up to 100,000 exposures • Offer 41 different image presets • Recommends optimal exposure time for each X-ray device • Size: <ul style="list-style-type: none"> - S2_1: Pediatrics - S2_2: Adult 	<p>The image shows two views of the S2 Intraoral Sensor. On the left is the S2_1 model, which is a smaller, rounded black device with a dome-shaped sensor head. On the right is the S2_2 model, which is a larger, rectangular black device with a flat sensor head. Both devices have a thin black cable extending from the bottom. The S2_2 device has 'OSSTEM' written vertically and 'S2' written horizontally on its front face.</p>
	<div style="display: flex; justify-content: space-around;"> S2_1 S2_2 </div>

Intraoral Camera

SNAP	
Description	Image
<ul style="list-style-type: none"> • Autofocus provides clear and vivid images with less distortion • Slim head design enables accessibility to wisdom teeth with ease • 160 degree contra angle provides ease of use • Two-way shooting buttons allows for comfortable handling of the device 	<p>The image shows the SNAP Intraoral Camera, a sleek, white and black handheld device. It has a long, thin handle with a black grip section and a black camera head at the top. The camera head is angled back, providing a contra-angle view. A thin black cable is attached to the bottom of the handle.</p>
SNAP004	

Orthodontic/Prosthetic

E-Driver	
Description	Image
<ul style="list-style-type: none"> • Strong and accurate application of torque (Range: 5~35Ncm) • Adjustable drilling speed (Range: 15~60rpm) • Minimizes OrthAnchor fractures and ensures accurate placement path • Ease of abutment tightening and minimizing the chance of screw loosening 	
OSM-TORQ	

Endodontics

UC Cutter	
Description	Image
<ul style="list-style-type: none"> • Trim and remove excessive tissue • Seal blood vessels to facilitate clot formation • Eliminate pathogens and bacteria • Sterilizes the treatment area for optimal hygiene 	
EP1017	

ISQ Stability Tester

IS4™	
Description	Image
<ul style="list-style-type: none"> • Precision Resonance Frequency Analysis (RFA) • Assess implant stability with the Implant Stability Quotient (ISQ) • Enhance implant success through accurate diagnostics • Achieve high-accuracy measurements for reliable results • Optimize loading protocols with precise data • User-Friendly design with single key operation 	
55250-HM	

Main Adapter
Image

55263

Adapter
Image / Item code

55267

IS4™ Charging Station
Image

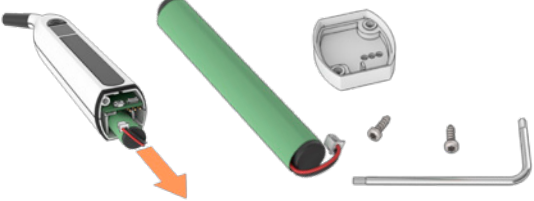
55245

IS4™ Battery Replacement Kit
Image

55291

MulTipeg™ Driver
Image / Item code

55245

MulTipeg™	
Description	Image
<ul style="list-style-type: none"> • Up to 20 times without any deviation • Reusable, auto-clavable, calibrated, and compatible with all major implant systems • Optical Platform Fit 	
*Page 300 - 303	

ISQ Stability Tester

IS3™	
Description	Image
<ul style="list-style-type: none"> • Resonance Frequency Analysis (RFA) • Implant Stability Quotient (ISQ) • Raise the implant success rate with accurate diagnosis • High accuracy measurement result • Determines optical loading protocol • Hand held instrument with single key operation 	
55002-HM	

Main Adapter
Image / Item code

55093

Adapter
Image / Item code

55097

MulTipeg™ Driver
Image / Item code

55003

MulTipeg™	
Description	Image
<ul style="list-style-type: none"> • Up to 20 times without any deviation • Reusable, auto-clavable, calibrated, and compatible with all major implant systems • Optical Platform Fit 	
*Page 300 - 303	

MulTipeg™ Assortment

	No	Type		No	Type		No	Type
AB Dental			Bio3			Dentalis		
Narrow Platform	55021	11	Advanced	55067	59	Regular	55051	43
Standard Platform	55049	41	Progressive	55067	59			
			BioHorizons			Dental Ratio		
ADIN			Laser-Lok 3.0 Grey	55034	26	Tissue Level RP, WP	55014	4
Touareg S/OS	55034	26	Internal Laser-Lok 3.5 Yellow	55049	41	Bone Level NC	55061	53
Touareg Closefit UNP 2.75	55059	51	Internal Laser-Lok 4.5 Green	55051	43	Bone Level RC	55062	54
Touareg Closefit NP 3.0	55059	51	Internal Laser-Lok 5.7 Blue	55051	43			
Touareg Closefit RP 3.5	55046	38	External 4.0 Platform	55011	1	Dental Tech		
Touareg CloseFit WP 4.3, 5.0	55067	59				Implassic FT3 3.25	55039	31
Swell 3.3	55034	26	Biomet/3i			Implassic FT3 3.75	55049	41
			External Hex	55011	1			
AIRES			Certain Internal Purple	55036	28	Dentegris		
3.3	55049	41	Certain internal Purple Platform 3.4	55036	28	3.3	55034	26
			Certain internal Blue, Yellow, Green	55066	58	3.75	55057	49
Alpha-Bio			T3 Purple	55036	28	4.5	55049	41
Internal Hex	55034	26	T3 Blue, Yellow, Green	55066	58	3.8/4.5	55049	41
Conical Hex 3.2	55065	57			5.5	55020	10	
Conical Hex 3.75-5.0	55051	43	Bionnovation			Dentis		
			Biomorse	55023	14	Cleanlant S-Clean 3.7 - 4.8	55020	10
Alfa Gate						S-Clean OneQ Narrow 3.3	55064	56
Bioactive, All diam	55034	26	Biotech Dental					
MAX, All diam	55034	26	Kontakt, Kontakt-S 3.6 - 4.8	55045	37	Dentium		
M+ NP 3.5	55044	36				Superline	55037	29
M+ RP 4.3 - 5.0	55037	29	BlueSkyBio			NR Line	55066	58
Porous, All diam	55034	26	BIO Max NP Platform, All	55046	38	Simple Line II GH 1,6	55014	4
			BIO Max RP Platform 4.3-5.0	55037	29			
Alpha Dent			BIO Int Hex 3.5 Platform 3.7-4.1	55049	41	DEVA		
Active Conus	55067	59	BIO Int Hex 3.5 Platform 4.7	55051	43	Bone Level 3.5	55064	56
Classic Conus	55067	59	BIO Int Hex 4.5 Platform 4.7-7.0	55051	43	Bone Level 4.5	55051	43
Active Bio	55067	59	BIO One-stage Narrow, Regular, Wide	55014	4			
Slim	55039	31	BIO One-stage Short Regular & Wide	55014	4	DIO		
			BIO Quattro Narrow 3.3	55061	53	SM Submerged 3.8	55049	41
Anker			BIO Quattro Regular 4.1 - 5.6	55062	54	SM Submerged 5.0	55020	10
SB III 3.5	55023	14	BIO Conus 12, 3.0 Platform 3.0	55064	56	UF II Narrow	55064	56
SB III 4.0-5.0	55020	10	BIO Conus 12, 3.5/4.0 Platform 3.5-4.0	55046	38	UF II Regular	55020	10
			BIO Conus 12, 4.5 x 6mm	55046	38			
Ankylos			BIO Conus 12, 4.5/5.0 Platform 4.5 - 5.0	55017	7	Easy Implant		
C/X	55025	16	BIO Conus 12, 5.0 x 6mm	55046	38	Ocean	55046	38
			BIO Trilobe 3.5	55016	6	Lilas	55037	29
Anthogyr			BIO Trilobe 4.3-6.0	55017	7			
Axiom Bone Level 3.4 - 5.2	55065	57	Bredent			Edierre		
Axiom Tri-lobe	55065	57	SKY	55025	16	3-lobe	55021	11
Axiom Tissue Level Narrow, Regular	55050	42	CopaSKY	55027	19	4-lobe	55025	16
			Mini2SKY	55033	25			
Argon			Fast & fixed Abutment	55083	75	Euroteknika		
K3pro Rapid 3.0 - 3.5	55026	17				Internal Platform 3.0	55064	56
K3pro Rapid Platf 3mm	55019	9	BTI			Internal Platform 3.5	55081	73
K3pro Rapid Platf 3mm Short	55044	36	Interna Universal	55051	43	Naturactis/Naturall+ 3.0	55064	56
			Interna Wide	55051	43	Naturactis 3.5-5.0	55081	73
Astra Tech						Uneva	55011	1
Osseospeed EV 3.0	55058	50	BTK			Galimplant		
Osseospeed EV 3.6	55046	38	External Hex EN	55038	30	iPx 4012	55046	38
Osseospeed EV 4.2	55057	49	External Hex ER	55011	1			
Osseospeed EV 4.8	55055	47	External Hex EW	55011	1	GC Tech		
Osseospeed EV 5.4	55048	40	Internal Hex IR	55049	41	Aadva Narrow	55081	73
Osseospeed TX 3.0 S	55064	56	Internal Hex IM	55051	43	Aadva Regular	55066	58
Osseospeed TX 3.5-4.0 S	55046	38	Internal Hex IW	55051	43			
Osseospeed TX 4.5-5.0 S	55017	7	Hexagonal Morse Taper KR	55081	73	Geass		
			Hexagonal Morse Taper KW	55056	48	Way Extra	55081	73
Avinent			Octagonal Morse Taper SR	55014	4			
External, Coral & Ocean 3.5	55038	30	Camlog			Global D		
External, Coral & Ocean 4.1	55011	1	Screw-Line, Root-Line 3.3	55036	28	In-Kone 4.0-5.0	55024	15
External, Coral 5.1	55013	3	Screw-Line, Root-Line 3.8, 4.3	55031	23			
Internal, Coral & Ocean 3.5, 4.1	55051	43				Geass		
Conical, Ocean 3.5	55066	58	Cowellmedi			Way Extra	55081	73
Conical, Ocean 4.1	55004	18	Inno Int Octa	55014	4	Global D		
			Inno Sub Hex	55037	29			
B&B Implant			C-Tech			GMI		
Duravit Slim	55021	11	EL	55067	59	Avantgard RP 3.75-4.25	55066	58
Duravit 3P	55035	27				Avantgard WP 4.75-5.75	55075	67
Duravit Evolution	55035	27	Dentack			Frontier RP/WP	55051	43
			Internal Hex	55056	48	Phoenix NP 3.3	55038	30
BEGO						Phoenix Std 3.3 - Wide 5.0	55011	1
Semados Mini	55012	2	Dentalis			Monolith 3.0	55043	35
Semados S / RI 3.25-5.5	55034	26	Regular	55051	43			
Semados RS / RSX 3.0	55082	74						
Semados RS / RSX 3.75-5.5	55034	26						
Semados SC / SCX 3.25-5.5	55034	26						

MulTipeg™ Assortment

	No	Type		No	Type		No	Type
GP Implants			Implantvision			Medentis		
SSI Spiral Shape implant	55051	43	Internal Hex 3.7-5.7	55034	26	ICX Premium 3.75 - 4.8	55062	54
GT Medical			Innobiosurg			ICX Plus 3.45	55039	31
HXE	55011	1	MagiCore Regular	55018	8	ICX Narrow	55058	50
HXE RP	55012	2	Intoss Anchor			Medical Instinct		
HXE WP	55013	3	Internal Hex 3.7-5.7	55088	80	Hex 3.0	55071	63
HXI 4.1	55037	29				Hex 3.4, 4.0, 5.0	55052	44
002 HXI 4.7	55049	41	Intra-lock			Cone 3.0, 3.4, 4.0	55071	63
OCT 4.3	55014	4	Intrahex 3.4 - 4.5	55051	43	Cone 5.0	55072	64
			Gold & Blue 3.4 - 6.0	55051	43			
Hahn			InDex 3.4 - 3.75	55015	5	Medigma Biomedical		
Tapered 3.0	55058	50	InDex 4.0 - 4.3	55020	10	Mars 3,5-6,0	55057	49
Tapered 3.5	55046	38	FlatTop 3.75	55012	2	FixTite 3,5-6	55057	49
Tapered 4.3	55046	38				Fix-a-Dent 3,75-6	55057	49
Tapered 5.0	55037	29	IRES					
Tapered 7.0	55048	40	External Hex Narrow 3.3	55012	2	Medimecca		
			External Hex Regular 3.7 - 5.2	55011	1	PT SLA Chaorum	55047	39
Hiossen			Internal Hex Narrow 3.3	55087	79			
HS System	55028	20	Internal Hex Regular 3.7 - 5.2	55049	41	Megagen		
ET System	55037	29	Internal Octagon Regular 3.7 - 5.2	55014	4	Anyridge	55051	43
ET 3.2	55047	39				Anyone Internal	55037	29
ET mini	55015	5	J Dental Care			Mini	55064	56
EK 3.2/3.5	55046	38	JDEvolution 3.7-6.0	55067	59	MUA	55080	72
EK 4.0	55044	36	JD Evolution S 3.25	55044	36			
			JD ICON ultra, S 2.75	55064	56	Microdent		
			Conical Abutment	55080	72	Universal	55011	1
Hi-Tec			Keystone			Microdent 2.8 - 3.25	55068	60
Tapered Self Thread NTI 3.3, SLT 3.75	55034	26	Prima / Connex Narrow	55049	41	Microdent 3.3 - 5.0	55011	1
Tapered Self Thread GTI 4.2, WTI 5.0	55051	43	Prima / Connex Regular	55067	59	Microdent 5.5 - 8.0	55013	3
Spark TPI	55034	26	Prima / Connex Wide	55041	33	Genius 3.0	55025	16
Logic Plus	55034	26	Prima / Genesis Narrow	55049	41	Genius 3.5 - 5.0	55051	43
Logic LGI 3.0-3.5	55046	38	Prima / Genesis Regular	55067	59	Ektos 3.2	55023	14
Logic LGI 4.3-5.0	55037	29	Prima / Genesis Wide	55041	33	Ektos 3.7 - 8.0	55051	43
			Restore Narrow	55079	71	Trylogic 3.5 - 4.2	55051	43
IDI Evolution			Restore Regular	55011	1	Trylogic 5.0	55075	67
Standard implant 3.75-4.0	55004	18	Restore Wide	55013	3			
B1One High	55080	72				MIS		
B1One Low	55033	25	Klockner			Conical connection Narrow (C1, V3)	55081	73
			VEGA Micro 3.0	55074	66	Conical connection Standard (C1, V3)	55087	79
IDI Implants			VEGA Narrow 3.5	55065	57	Conical connection Wide (C1)	55041	33
ID Cam ST 4.2	55010	13	VEGA Regular 4.0, 4.5	55034	26	Seven and M4 Narrow	55027	19
ID All	55010	13	KL Narrow 3.3	55012	2	Seven and M4 Standard	55049	41
IDS			KL Regular 3.7, 4.2	55011	1	Seven Wide 5.0	55051	43
Reflect Aspire	55081	73	KL Wide 4.7	55013	3	Connect abutment NP, SP, WP	55115	81
Reflect Certus	55019	9	SK2	55038	30			
Reflect Tapered	55034	26	Essential Cone	55067	59	Neo Biotech		
Reflect Recover	55020	10	S3M 3.1	55079	71	IS II 4.0	55020	10
Reflect Rapid	55020	10				IS III 4.0	55020	10
Implance			Konmet			Neodent		
Tissue level	55014	4	Classic 4.0, 4.8	55014	4	Drive CM	55025	16
Bone level Regular	55037	29	Cylindrical 3.5-4.0	55065	57	Titamax WS Cortical	55056	48
Bone level 3.3	55065	57	Cylindrical 4.5-5.5	55057	49	GM	55066	58
			Short Cylindrical 5.0-6.0	55078	70			
Implant One			Conical 4.4/3.4	55065	57	Neodent		
100 Series Std thread	55029	21	Conical 4.8/3.8, 5.5/4.5	55057	49	Drive CM	55025	16
200 Series Std thread	55029	21				Titamax WS Cortical	55056	48
300 Series Std thread (blue)	55029	21	Lasak			GM	55066	58
400 Series Std thread (purple)	55035	27	BioniQ QR	55066	58			
500 series Std thread (green)	55035	27	BioniQ QN	55021	11	Neoss		
300 Series Wide thread (blue)	55029	21				SP (Ø 3.5 implants and wider)	55004	18
400 Series Wide thread (purple)	55035	27	Leader			NP (Ø 3.25)	55027	19
500 Series Wide thread (green)	55035	27	Internal Hex, 3.3 - 5.5 mm	55034	26	Access Abutment	55060	52
			Cono-In	55067	59			
Implant Direct			Maxillent			Nobel Biocare		
Legacy 1/2/3/4 3.0/3.2	55012	2	iRaise	55049	41	Brånemark System Ext hex RP	55011	1
Legacy 1/2/3/4 3.5/3.7 - 5.7/7.0	55051	43				Brånemark System Ext hex NP	55012	2
RePlant 3.5	55022	12	Medentika			Brånemark System Ext hex WP	55013	3
RePlant 4.3 - 5.0	55010	13	Microcone NI	55021	11	Tri-lobe Connection NP	55022	12
RePlant 6.0	55032	24	Microcone RI	55081	73	Tri-lobe Connection RP, WP	55010	13
ReActive 3.5 Platform	55022	12	Quattrocone RI	55081	73	Tri-lobe Connection 6.0	55032	24
ReActive 4.3 - 5.0 Platform	55010	13	Quattrocone 30 Al	55081	73	Conical Connection 3.0	55058	50
Interactive 3.0 Platform	55046	38	Procone 3.3	55119	85	Conical Connection Narrow	55046	38
Interactive 3.4 Platform	55037	29	Procone 3.8	55031	23	Conical Connection Regular	55037	29
Screwindirect 5.0 PF 3.0 - 5.7	55070	62	Procone 4.3	55031	23	Conical Connection Wide 5.5	55048	40
			Procone 5.0	55032	24	MUA NP & RP	55080	72
Implant Swiss						On1 NP, RP, WP	55042	34
Tissue level	55014	4						
Bone level Regular	55037	29						
Bone level 3.3	55065	57						

MulTipeg™ Assortment

	No	Type		No	Type		No	Type
Noris Medical			Quest			Sweden & Martina		
Tuff 3.3 - 6.0	55034	26	Hylock NP	55030	22	Syra, Syra SP 3.9-5.0	55011	1
			Hylock RP	55066	58	Outlink2 3.75, 4.10, 5.0	55011	1
Novem						Shelta 3.8-5.0	55025	16
3.4	55039	31	Resista			Premium Straight & SP 3.3-3.8	55025	16
3.8	55016	6	WIS 3.0-5.0	55049	41	Kohno Straight & SP 3.3-3.8	55025	16
4.2, 5.0	55057	49				Premium Straight & SP 4.25-6.0	55004	18
NucleOss			Rex Implants			Kohno Straight & SP 4.25-6.0	55004	18
Tpure Bone Level	55004	18	External hex TL 1.8	55060	52	Prama 3.8 - 5.0	55079	71
T6 Bone1 Level	55074	66	Internal hex TL 2.9	55034	26	DAT Connection	55035	27
OCO Biomedical			Ritter			Tag Dental		
Engage 3.25	55027	19	Spiral SB/LA Narrow PF 2.9	55081	73	Axis	55051	43
Engage 4.0-6.0	55051	43	Spiral SB/LA Standard PF 3.75	55049	41	massif	55051	43
ERI 3.25	55069	61						
ERI 4.0-5.0	55014	4	RS Implant			Tatum		
TSI 3.25	55068	60	3.5 - 6.0	55020	10	Integrity 3.7 - 5.0	55015	5
TSI 4.0-5.0	55011	1				Integrity 6.0 - 8.0	55040	32
			Schutz Dental			T implant	55063	55
OsseoFuse			Impla cylindrical	55052	44			
Hexaplus, Sinusplus	55081	73	IMPLA micro Retention Cone 4.2	55052	44	Simply Implants		
						Internal Hex	55051	43
Osstem			SGS Implant					
US Regular	55011	1	P1, P7 Platform	55049	41	SIN		
US Mini	55012	2	P1D, P7D	55049	41	Strong SW CM	55023	14
US Wide	55013	3	P7N	55059	51	Strong SW Int Hex	55035	27
US Wide PS	55011	1				Unitite CM 2.9	55084	76
SS Regular, Wide	55028	20	SIC invent			Unitite CM 3.5	55077	69
TS Regular, Reg Short, Diam 6 & 7	55037	29	SIcace 3.4 - 5.0	55052	44	Unitite CM Compact 4.0	55085	77
TS Mini 3.5	55015	5	SIcmax, SIctapered 3.7 - 5.2	55052	44	Tryon 3.25 - 5.0	55011	1
TS Mini 3.0	55047	39	SIcVantage® max, SIcVantage tapered 3.0	55026	17			
			SIcVantage® max, SIcVantage tapered 3.7	55116	82	Southern Implants		
			SIcVantage® max, SIcVantage tapered 4.2-5.2	55054	46	Tri-Nex 4.3-5.0	55010	13
			MUA	55120	86	Tri-Nex 3.5	55022	12
Osteo Plus						External Hex	55011	1
Iridium PF 3.8 & 4.2	55079	71	Simply Implants			MAX Ext Hex	55011	1
She 3.45, 3.75	55011	1	Internal Hex	55051	43	Co-Axis Ext Hex	55011	1
Shi 3.75, 4.2	55049	41				Piccolo Ext Hex	55050	42
Shi 5.0	55051	43	SIN			IT-Connection	55014	4
			Strong SW CM	55023	14	Deep Conical 3.0	55064	56
OT-Medical			Strong SW Int Hex	55035	27	Deep Conical 3.5-4.0	55046	38
OT-F2 3.4, 3.8	55053	45	Unitite CM 2.9	55084	76	Deep Conical Tapered 5.0	55017	7
OT-F2 4.1, 5.0	55073	65	Unitite CM 3.5	55077	69			
			Unitite CM Compact 4.0	55085	77	Spiral Tech		
Overmed			Tryon 3.25 - 5.0	55011	1	ESi, Hex connection	55051	43
Easyline Easydip	55020	10				Ultimate, Hex connection	55051	43
			Southern Implants			ESi Conical 3.5	55044	36
Oxy Implant			Tri-Nex 4.3-5.0	55010	13	ESi Conical 4.3, 5.0	55037	29
Internal	55020	10	Tri-Nex 3.5	55022	12			
Kone Conical Narrow	55021	11	External Hex	55011	1	Straumann		
Kone Conical Regular	55051	43	MAX Ext Hex	55011	1	Tissue level, Regular & Wide Neck	55014	4
PSK Line Regular	55051	43	Co-Axis Ext Hex	55011	1	Tissue level, Narrow Neck Crossfit (NNC)	55076	68
External Mini	55079	71	Piccolo Ext Hex	55050	42	Bone level / Bone Level Tapered Narrow	55061	53
External Regular	55011	1	IT-Connection	55014	4	Bone level / Bone Level Tapered Regular	55062	54
External Maxi	55011	1	Deep Conical 3.0	55064	56	Bone level / Bone Level Tapered SC 2.9	55064	56
			Deep Conical 3.5-4.0	55046	38	Bone Level X (BLX) all platform	55027	19
Paltop			Deep Conical Tapered 5.0	55017	7	Screw retained Abutment NP, RP	55080	72
Standard 3.75-5.0	55034	26						
Narrow	55027	19	Spiral Tech			Surgikor		
PCA Conical	55066	58	ESi, Hex connection	55051	43	Fixation 3.0	55058	50
			Ultimate, Hex connection	55051	43	Fixation 3.5	55066	58
Phibo			ESi Conical 3.5	55044	36	Fixation 4.3	55037	29
Aurea EVO NP	55027	19	ESi Conical 4.3, 5.0	55037	29	Solution 3.5, 4.0	55066	58
Aurea EVO RP, WP	55051	43				Solution 4.5, 6.0	55037	29
TSA S3	55074	66	Straumann			Immediate, all	55049	41
TSA S4, S5	55034	26	Tissue level, Regular & Wide Neck	55014	4	Versatile, all	55049	41
TSH S3, S4, S5	55011	1	Tissue level, Narrow Neck Crossfit (NNC)	55076	68			
			Bone level / Bone Level Tapered Narrow	55061	53	Sweden & Martina		
P-I Brånemark			Bone level / Bone Level Tapered Regular	55062	54	Syra, Syra SP 3.9-5.0	55011	1
HEX 3.3	55115	81	Bone level / Bone Level Tapered SC 2.9	55064	56	Outlink2 3.75, 4.10, 5.0	55011	1
HEX 3.75 -5.0	55117	83	Bone Level X (BLX) all platform	55027	19	Shelta 3.8-5.0	55025	16
AMP 3.3	55039	31	Screw retained Abutment NP, RP	55080	72	Premium Straight & SP 3.3-3.8	55025	16
AMP 3.75 - 4.8	55118	84				Kohno Straight & SP 3.3-3.8	55025	16
MT 3.3 - 4.8	55046	38				Premium Straight & SP 4.25-6.0	55004	18
			Surgikor			Kohno Straight & SP 4.25-6.0	55004	18
Prodent Italia			Fixation 3.0	55058	50	Prama 3.8 - 5.0	55079	71
Twinner & Prime, Conomet, Collar: Orange	55027	19	Fixation 3.5	55066	58	DAT Connection	55035	27
Twinner & Prime, Conomet, Collar: Fuchsia	55051	43	Fixation 4.3	55037	29			
Twinner & Prime, Conomet, Collar: Green	55067	59	Solution 3.5, 4.0	55066	58			
Twinner & Prime, Conomet, Collar: Yellow	55020	10	Solution 4.5, 6.0	55037	29			
Prime, Conomet, Collar: Blue	55020	10	Immediate, all	55049	41			
			Versatile, all	55049	41			

MulTipeg™ Assortment

No			Type	No			Type	No			Type				
Sweden & Martina															
Syra, Syra SP 3.9-5.0	55011	1		Ticare											
Outlink2 3.75, 4.10, 5.0	55011	1		Osseus Mini, Standard	55011	1		Vulkan				55034	26		
Shelta 3.8-5.0	55025	16		Osseus Maxi	55013	3		Internal Hex							
Premium Straight & SP 3.3-3.8	55025	16		Osseus Maxi ps	55011	1		External Hex NP				55012	2		
Kohno Straight & SP 3.3-3.8	55025	16		Inhex Mini	55021	11		External Hex RP				55011	1		
Premium Straight & SP 4.25-6.0	55004	18		Inhex Standard	55046	38		Conical con MIP				55058	50		
Kohno Straight & SP 4.25-6.0	55004	18		Inhex Maxi	55017	7		Conical con NP				55046	38		
Prama 3.8 - 5.0	55079	71		Osseus Quattro Standard	55011	1		Winsix							
DAT Connection	55035	27		Inhex Quattro Standard	55046	38		Internal Hex				55020	10		
Tag Dental															
Axis	55051	43		TRATE				Xgate							
Massif	55051	43		ROOTFORM	55065	57		Conical 3.3 - 5.0				55034	26		
Tatum															
Integrity 3.7 - 5.0	55015	5		TRI Dental implants				Xive							
Integrity 6.0 - 8.0	55040	32		Tissue level Octa	55014	4		S-Plus 3.0				55030	22		
T Implant	55063	55		Tri-Vent, all	55034	26		S-Plus 3.4				55061	53		
TBR															
Infinity PF 3.5, PF 4.0	55004	18		Narrow	55025	16		S-Plus 3.8-5.5				55062	54		
M Implant	55044	36		Trinon				TG Plus 3.4-4.5				55018	8		
Thommen															
SPI 3.5	55021	11		Q2-Implant	55011	1		Zeramex							
SPI 4.0	55065	57		QK-Implant	55014	4		XT Implant 4.2, 5.5				55086	78		
SPI 4.5-6.0	55066	58		QZA 3.5 Platform	55049	41		Zimmer							
URIS															
				QZA 4.5, 5.7 Platform	55051	43		Screw-Vent, Tapered Screw-Vent 3.7-4.1				55049	41		
				Omni Narrow 3.0-3.5	55115	81		Screw-Vent, Tapered Screw-Vent 4.7-5.7				55051	43		
				Omni Regular 4.0-6.5	55020	10		Tapered Swiss Platf 3.8				55070	62		
								Tapered Swiss Platf 4.8				55014	4		
								Spline Twist Platt 4 & 5				55038	30		
								Eztetic NP 3.1				55065	57		
Zuga															
								All				55027	19		

HIOSEN
IMPLANT



Order Online

eshop.hiossen.com

Order our complete range of implants and dental supplies at Hiossen Implant online store.



Hiossen Implant 2026 Product Catalog

Production/Distribution Marketing Headquarters

Date of Publication 05.2026

Version PC26HPCLTR1.1



Copyright © 2026 Hiossen Inc. All rights reserved.

105 Challenger Rd. 7th Floor, Ridgefield Park, NJ 07660

Marketing@hiossen.com | 888.678.0001 | www.hiossen.com

All Hiossen Implants are processed and Manufactured in the USA

Disclaimer: Products shown in this catalog may not be available in all countries. Product availability is subject to regulatory approval in each market. All products are intended for use by licensed dental professionals only and must be used in accordance with the applicable Instructions for Use (IFU). Product specifications, indications, and availability are subject to change without prior notice. Illustrations shown in this catalog are for reference purposes only and may not represent the exact size or configuration of the actual product.



Order Online
eshop.hiossen.com

Order our complete range of implants and dental supplies at Hiossen Implant online store.



**Hiossen Implant
2026 Product Catalog**

Production/Distribution Marketing Headquarters
Date of Publication 05.2026
Version PC26HPCLTR1.1



Copyright © 2026 Hiossen Inc. All rights reserved.
105 Challenger Rd. 7th Floor, Ridgefield Park, NJ 07660
Marketing@hiossen.com | 888.678.0001 | www.hiossen.com
All Hiossen Implants are processed and Manufactured in the USA

HIOSSEN
IMPLANT

Disclaimer: Products shown in this catalog may not be available in all countries. Product availability is subject to regulatory approval in each market. All products are intended for use by licensed dental professionals only and must be used in accordance with the applicable Instructions for Use (IFU). Product specifications, indications, and availability are subject to change without prior notice. Illustrations shown in this catalog are for reference purposes only and may not represent the exact size or configuration of the actual product.